

1:	8.5	↙
2:	9.7	↗
3:	9.8	↙
4:	*10.6	↘
5:	10.3	↙
6:	*10.6	↘
Serie		56.0
Total		0.0

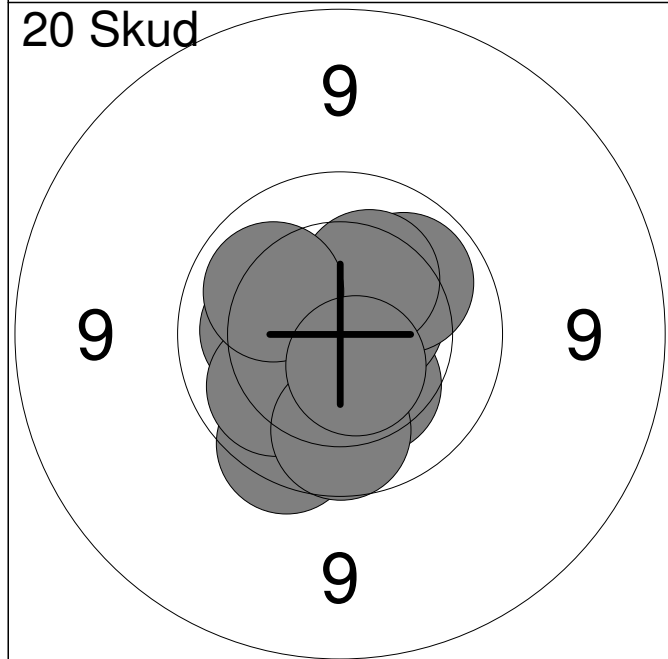

1:	10.2	←
2:	9.8	↙
3:	10.1	↙
4:	10.3	↘
5:	*10.5	→
6:	10.1	↗
7:	9.9	↘
8:	10.3	↗
9:	10.1	↗
10:	*10.6	↘
Serie		98.0
Total		98.0

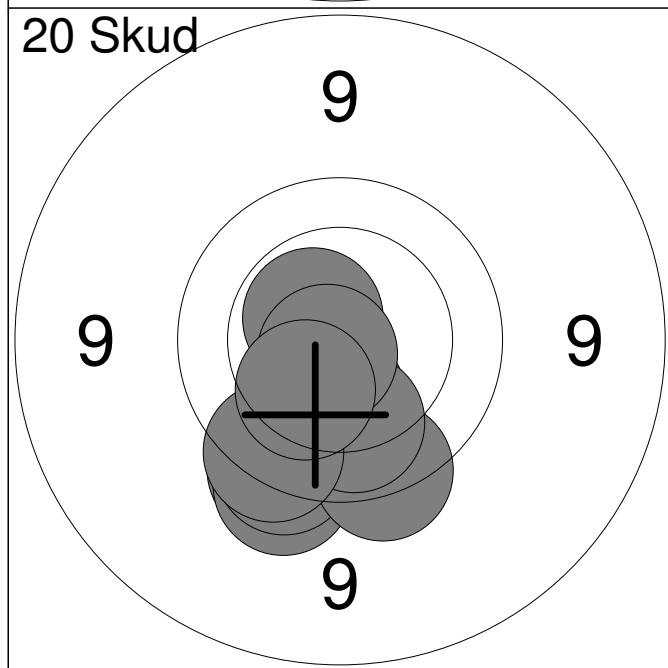

11:	10.3	↘
12:	9.6	↙
13:	9.6	↙
14:	*10.6	↗
15:	9.7	↙
16:	9.7	↘
17:	10.0	↘
18:	9.7	↙
19:	*10.7	↙
20:	10.3	↙
Serie		95.0
Total		193.0

Hold 1	Skive 2	Niels Løjengaard Hermansen	
------------------	-------------------	-----------------------------------	--

15m	Mou & Omegns Skf.	BK3
-----	-------------------	-----

1/3 - 3/3 2013	NM 15 meter Ungdom 2013	Aalborg Skyttekreds
----------------	-------------------------	---------------------

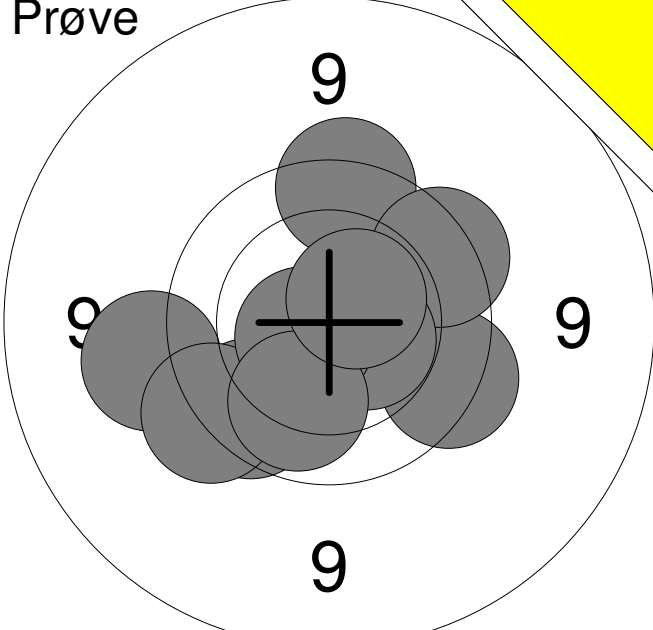
Prøve 	1: 9.7	→
	2: 9.4	←
	3: 9.8	↙
	4: 9.7	↑
	5: 9.7	↗
	6: *10.5	→
	7: 9.6	↙
	8: *10.6	↙
	9: 10.0	↓
	10: *10.6	↗
	Serie	94.0
Total	0.0	

20 Skud 	1: 9.8	↙
	2: 10.1	↑
	3: 10.1	←
	4: *10.5	↓
	5: 9.9	←
	6: 10.4	→
	7: 10.2	↓
	8: 10.1	↙
	9: 10.2	↓
	10: 10.0	↑
	Serie	98.0
Total	98.0	

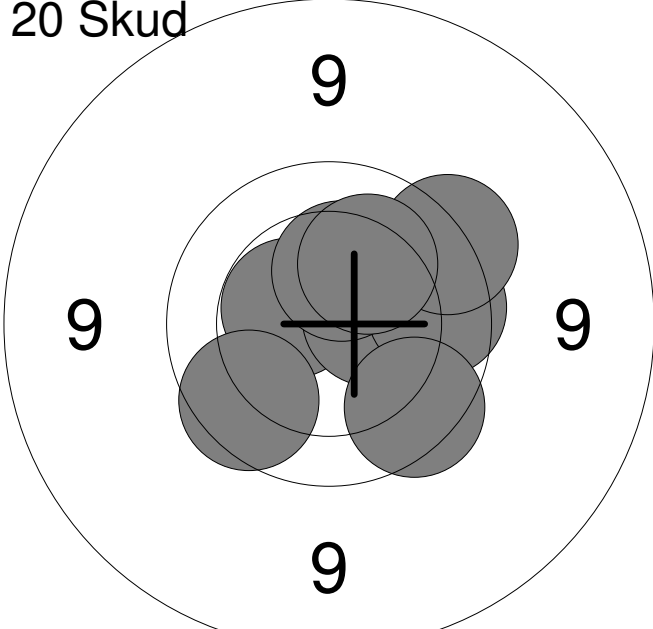
20 Skud 	11: 10.2	↗
	12: *10.5	↙
	13: 10.0	→
	14: 10.5	→
	15: 9.9	→
	16: 9.8	↙
	17: 9.6	↗
	18: 10.4	↑
	19: 9.8	↓
	20: 10.2	↗
	Serie	96.0
Total	194.0	

Hold 1	Skive 3	Jeppe Niss	
------------------	-------------------	-------------------	--

15m	Mou & Omegns Skf.	BK3
-----	-------------------	-----

1/3 - 3/3 2013	NM 15 meter Ungdom 2013	Aalborg Skyttekreds
----------------	-------------------------	---------------------

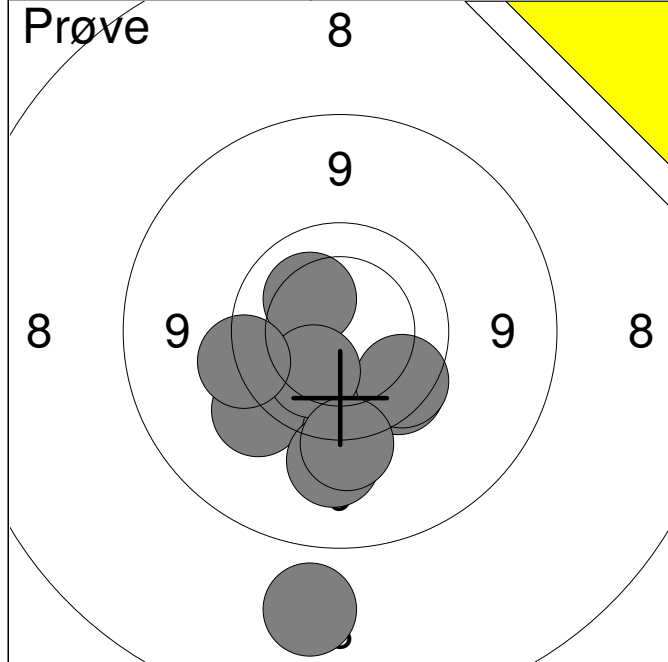

1:	8.3	↓
2:	10.2	↗
3:	9.8	↓
4:	9.8	↓
5:	9.5	↙
6:	9.8	↓
7:	9.3	↓
8:	10.2	↙
9:	9.6	←
10:	9.5	↓

Serie	91.0
Total	0.0

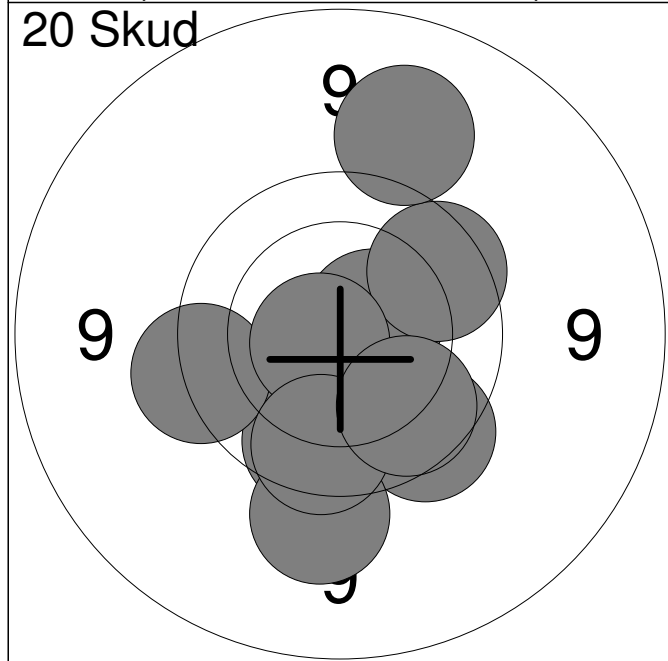

1:	9.7	↓
2:	*10.6	→
3:	9.8	↓
4:	9.4	↓
5:	9.8	↗
6:	9.6	←
7:	*10.7	←
8:	9.8	↓
9:	9.9	↘
10:	9.2	↗

Serie	92.0
Total	92.0

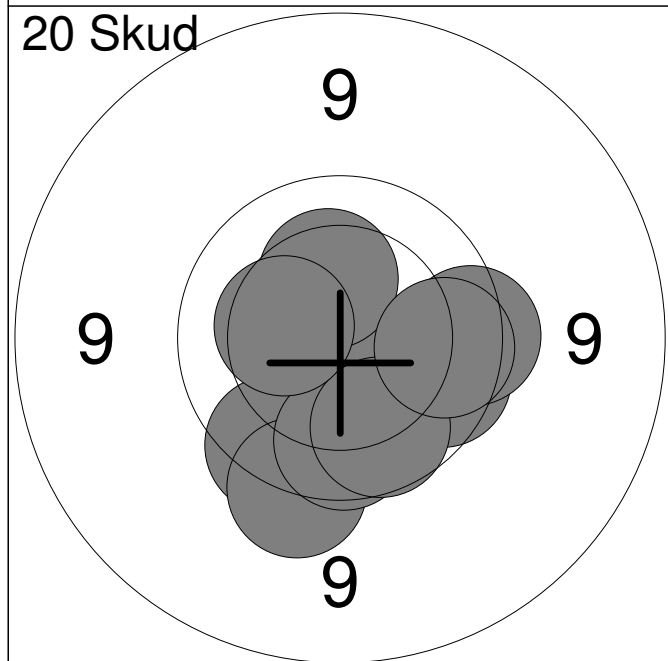

11:	*10.7	↗
12:	9.7	↓
13:	9.8	↗
14:	9.6	↓
15:	9.7	→
16:	9.9	↓
17:	10.3	↑
18:	9.9	↓
19:	10.3	←
20:	9.9	→

Serie	93.0
Total	185.0

Hold 1	Skive 4	Niels Kaasing	
------------------	-------------------	----------------------	--

15m	Mou & Omegns Skf.	J2
-----	-------------------	----

1/3 - 3/3 2013	NM 15 meter Ungdom 2013	Aalborg Skyttekreds
----------------	-------------------------	---------------------

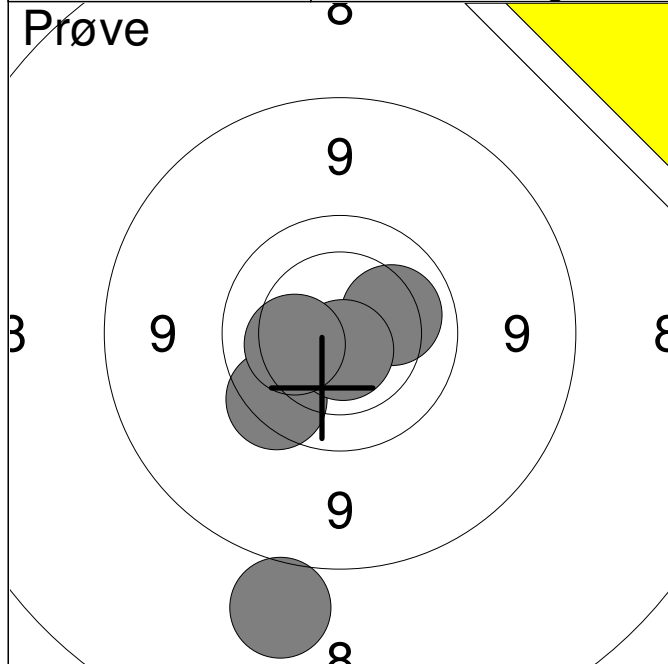

1:	8.4	↓
2:	9.7	↙
3:	10.1	→
4:	*10.7	↓
5:	10.3	↙
Serie		47.0
Total		0.0

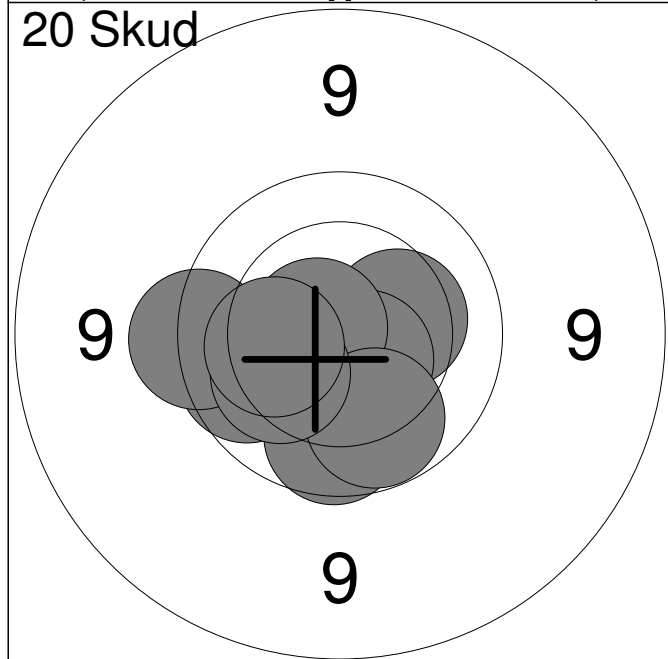

1:	10.2	↓
2:	10.3	→
3:	9.9	↓
4:	*10.6	↘
5:	*10.7	↙
6:	9.9	↙
7:	9.7	↙
8:	10.0	↓
9:	10.2	↙
10:	10.2	↙
Serie		97.0
Total		97.0

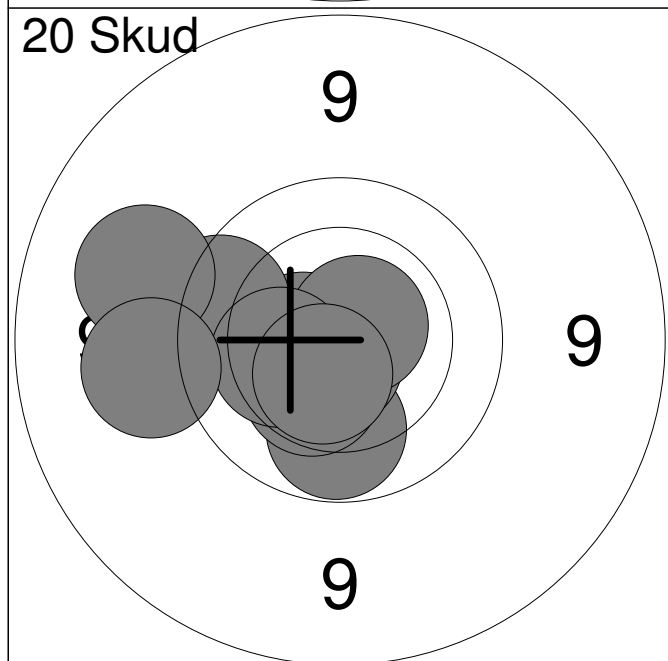

11:	10.0	↓
12:	*10.7	↓
13:	10.4	↘
14:	*10.5	↙
15:	9.8	↙
16:	9.3	↙
17:	*10.7	↗
18:	10.3	↙
19:	9.3	↙
20:	*10.5	↘
Serie		97.0
Total		194.0

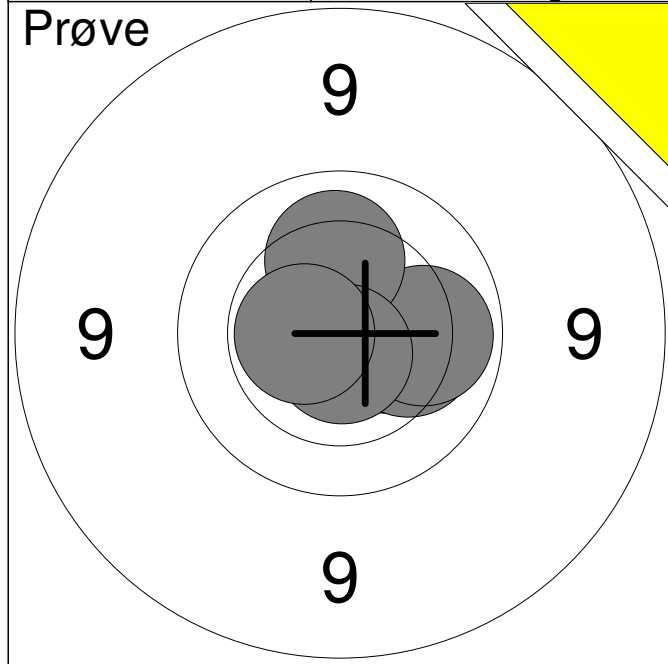

1:	10.4	→
2:	10.2	→
3:	10.1	→
4:	10.2	↑
5:	*10.7	↓
6:	*10.6	←
Serie		60.0
Total		0.0

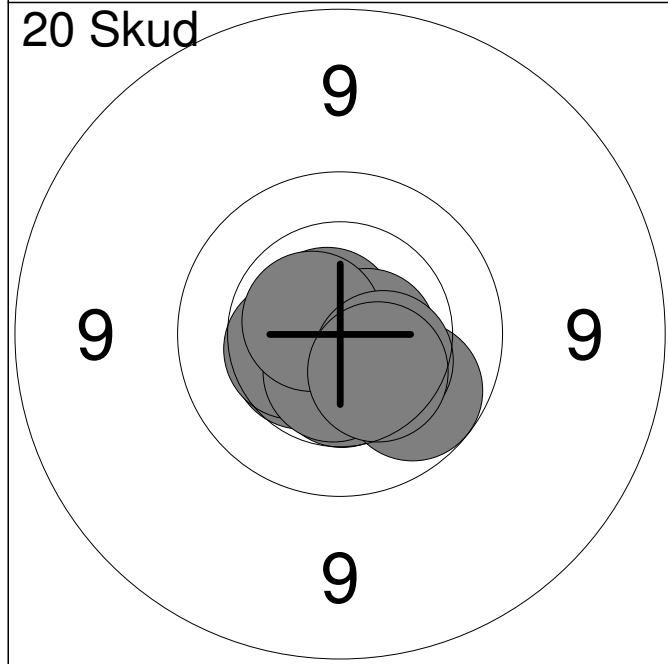

1:	10.5	↙
2:	*10.7	↗
3:	10.4	↙
4:	*10.7	→
5:	10.5	↓
6:	10.0	↘
7:	*10.5	↓
8:	*10.6	↗
9:	10.4	↘
10:	10.4	↘
Serie		100.0
Total		100.0

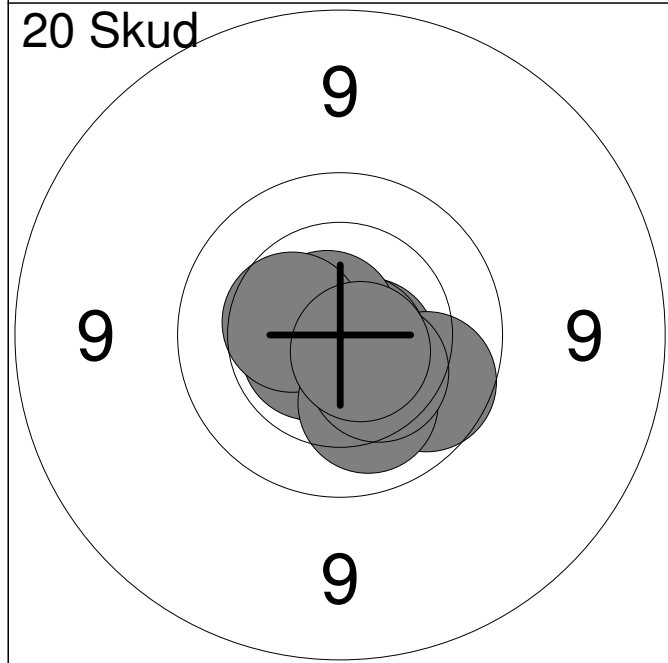

11:	*10.6	↘
12:	*10.7	↙
13:	*10.6	↙
14:	9.9	↘
15:	*10.7	↘
16:	*10.7	↗
17:	10.4	↗
18:	10.2	↘
19:	10.4	↘
20:	*10.7	↘
Serie		99.0
Total		199.0

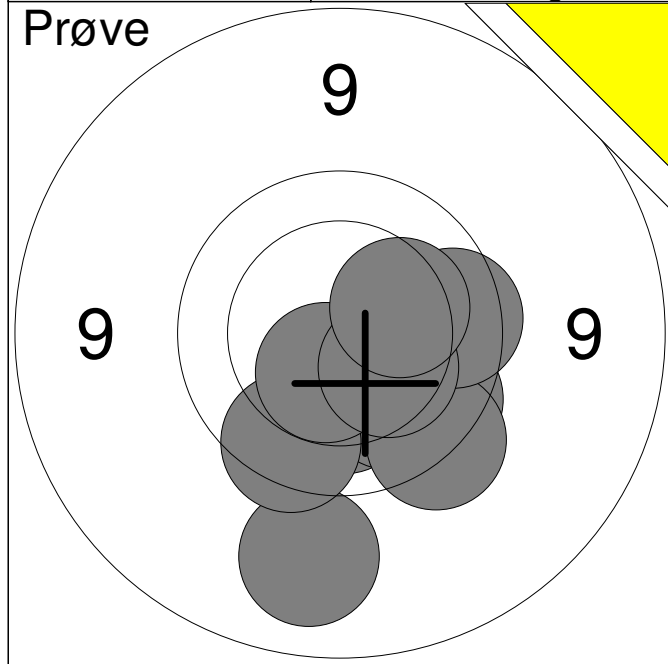

1:	9.1	↓
2:	10.2	↓
3:	9.8	↓
4:	10.0	↓
5:	9.6	↓
6:	9.8	↓
7:	*10.5	↓
8:	9.8	→
9:	10.3	↓
10:	10.2	→
Serie		95.0
Total		0.0

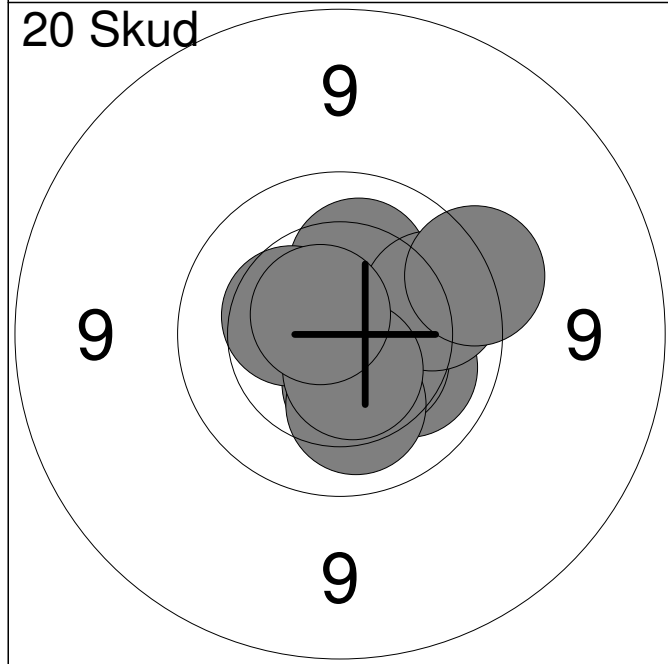

1:	10.2	↑
2:	10.4	↓
3:	10.1	→
4:	10.4	↓
5:	9.9	→
6:	9.6	→
7:	10.4	←
8:	10.2	↓
9:	*10.5	↓
10:	*10.7	↑
Serie		98.0
Total		98.0

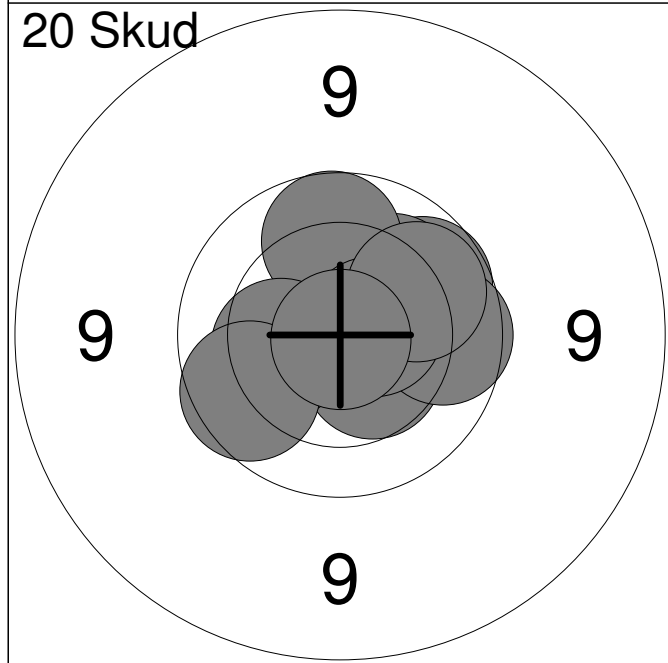

11:	10.4	↓
12:	9.9	→
13:	10.2	↗
14:	9.9	→
15:	9.9	↑
16:	*10.6	→
17:	10.3	←
18:	10.0	→
19:	9.9	↙
20:	*10.9	↓
Serie		96.0
Total		194.0

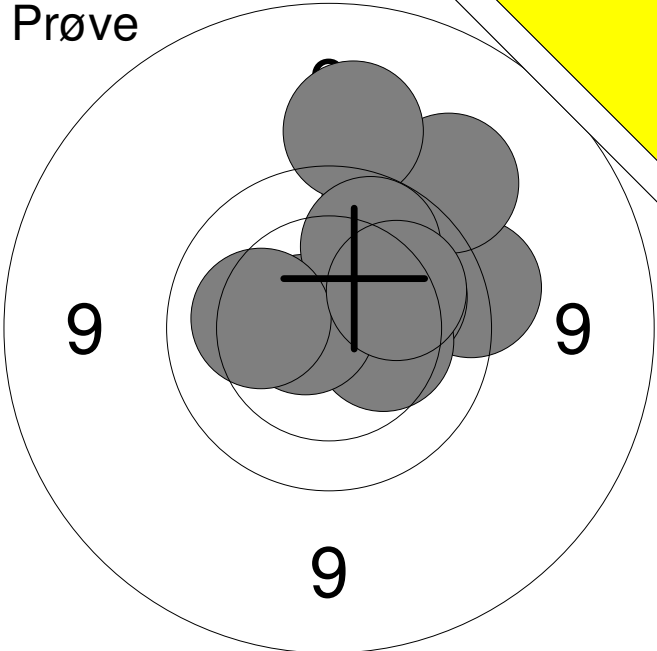
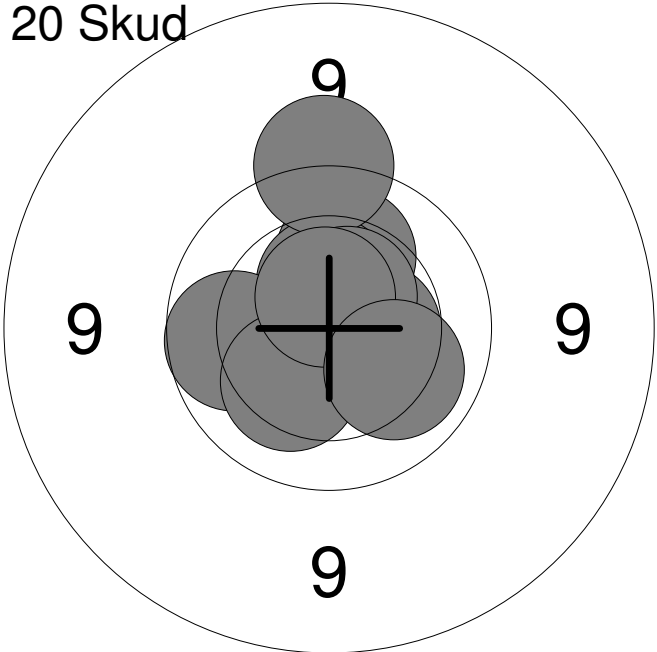
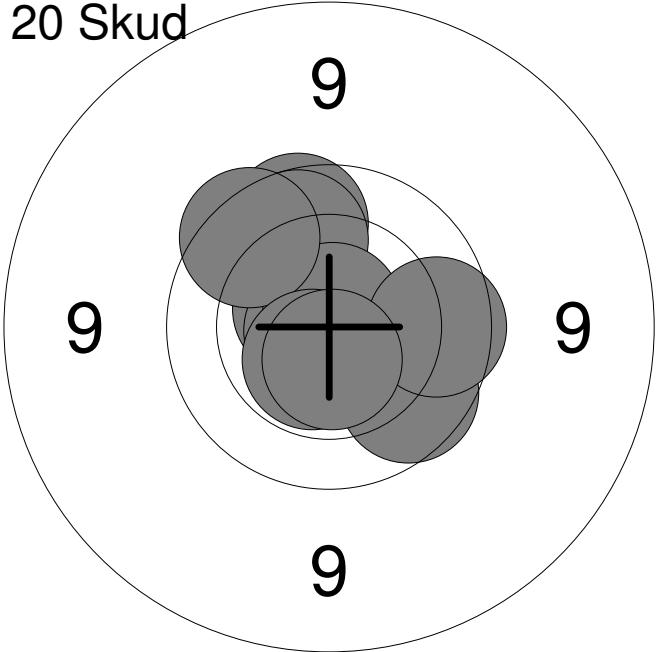
Hold	Skive			
1	9	Mie Larsen		
15m	Vester Han Herred SkytteforeningBK3		BK3	
1/3 - 3/3 2013	NM 15 meter Ungdom 2013		Aalborg Skyttekreds	
Prøve 	1:	9.7	↗	
	2:	9.6	→	
	3:	9.4	↗	
	4:	10.1	→	
	5:	9.3	↑	
	6:	10.3	→	
	7:	*10.7	←	
	8:	10.0	↗	
	9:	10.2	←	
	10:	10.1	↗	
	Serie			96.0
Total			0.0	
20 Skud 	1:	10.2	←	
	2:	10.2	↑	
	3:	*10.5	↑	
	4:	9.5	↑	
	5:	*10.5	→	
	6:	*10.6	↗	
	7:	9.9	←	
	8:	10.2	↙	
	9:	*10.6	↑	
	10:	10.1	↘	
	Serie			98.0
Total			98.0	
20 Skud 	11:	9.9	↑	
	12:	9.9	↘	
	13:	*10.6	↗	
	14:	*10.8	←	
	15:	10.0	↑	
	16:	*10.8	↑	
	17:	9.8	↗	
	18:	*10.6	↙	
	19:	9.9	→	
	20:	*10.6	↓	
	Serie			96.0
Total			194.0	

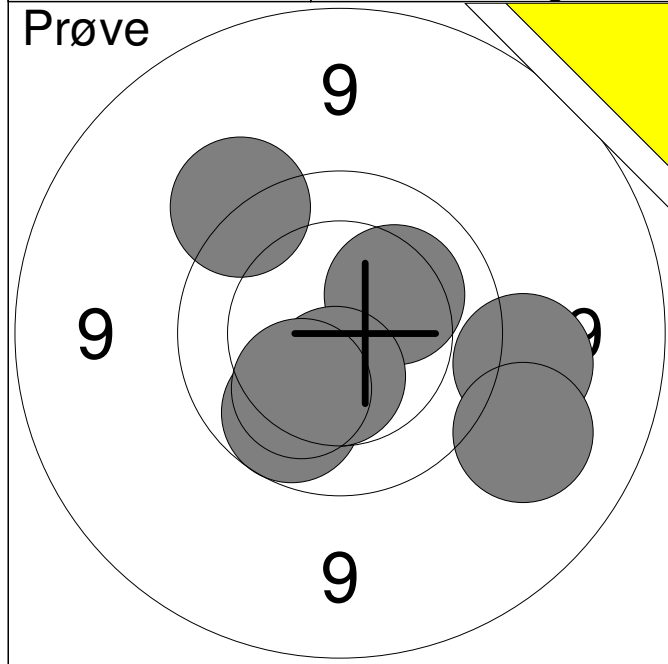

1:	10.2	↗
2:	9.4	→
3:	9.9	↙
4:	10.5	↓
5:	9.5	↗
6:	9.2	↘
7:	10.2	↙
Serie		66.0
Total		0.0

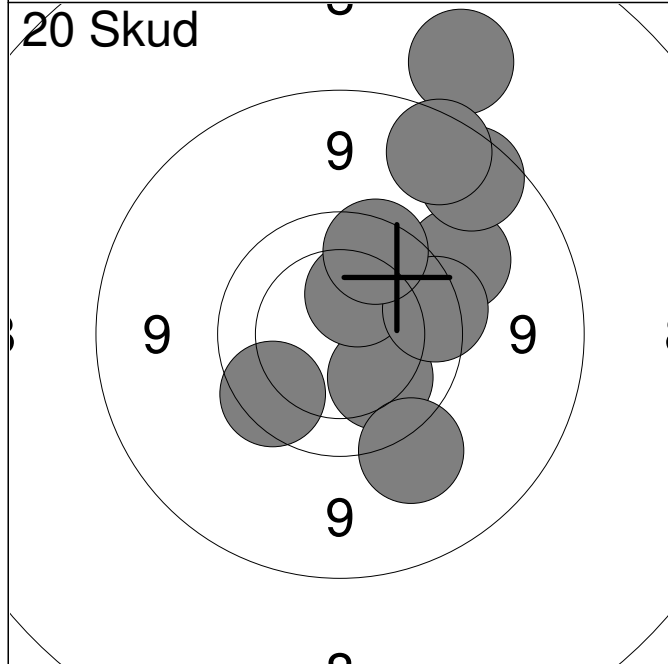

1:	10.1	↘
2:	9.4	↗
3:	10.3	↑
4:	8.4	↑
5:	9.8	↙
6:	8.9	↗
7:	8.9	↗
8:	9.4	↘
9:	9.7	→
10:	9.8	↑
Serie		89.0
Total		89.0

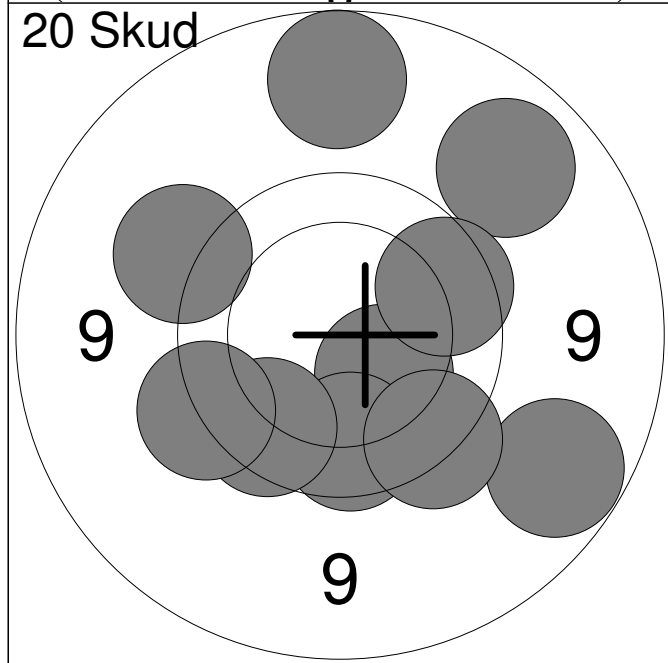

11:	9.4	↖
12:	10.3	↘
13:	8.9	↑
14:	9.9	↓
15:	9.1	↗
16:	9.8	→
17:	9.8	↙
18:	9.6	↙
19:	9.0	↘
20:	9.7	↘
Serie		90.0
Total		179.0

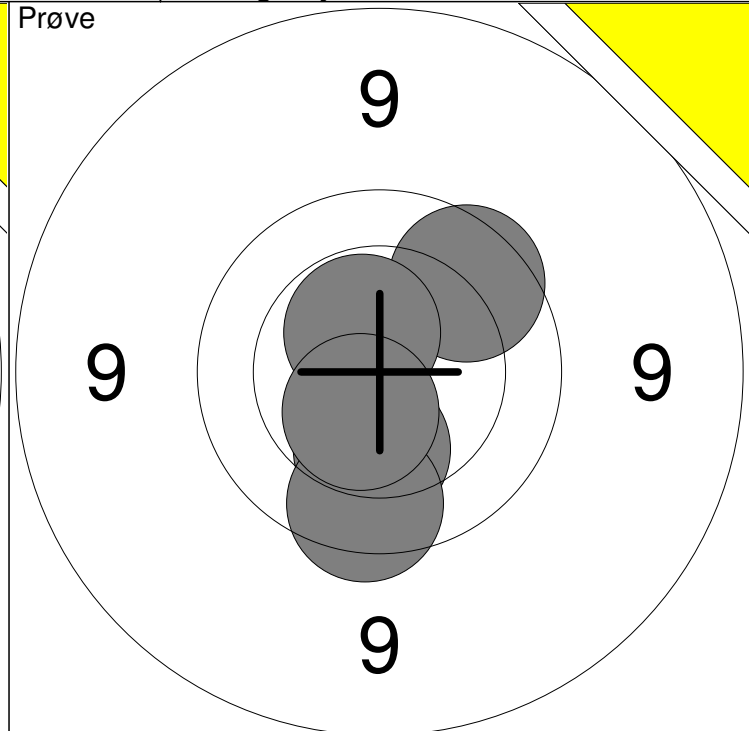
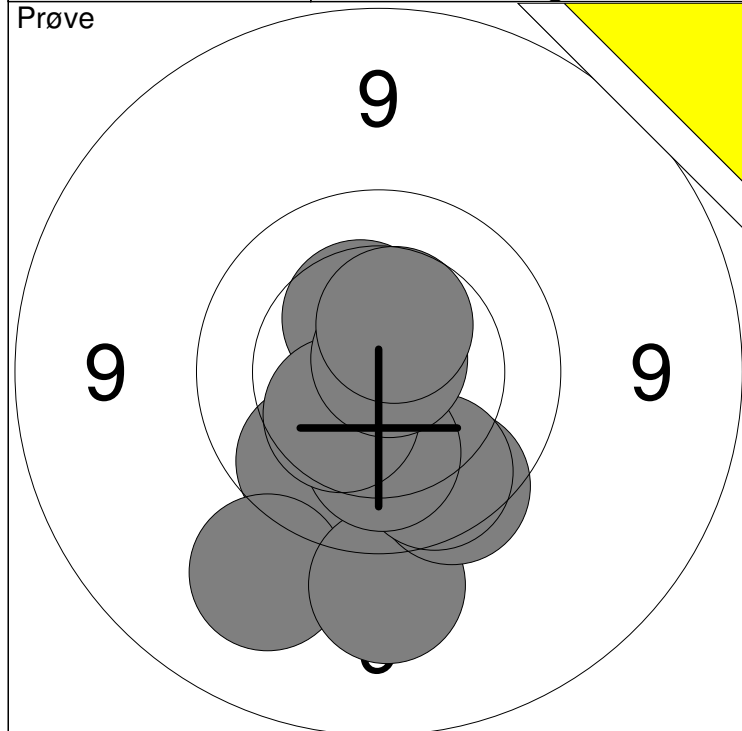

1: 9.9 ↘	6: 9.9 ↘	Serie 95.0
2: 9.3 ↘	7: 10.2 ↓	
3: 9.3 ↓	8: 10.4 ↙	Total 0.0
4: 9.8 ↘	9: *10.8 ↗	
5: 10.4 ↗	10: 10.5 ↗	

11: 10.2 ↓	Serie 48.0
12: 9.8 ↓	
13: 9.8 ↗	Total 0.0
14: *10.5 ↖	
15: *10.5 ↘	

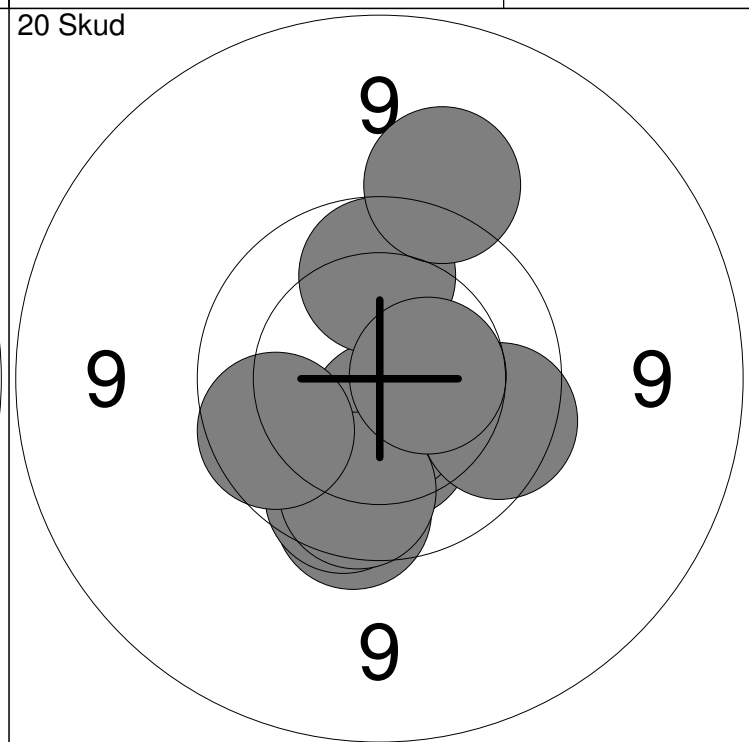
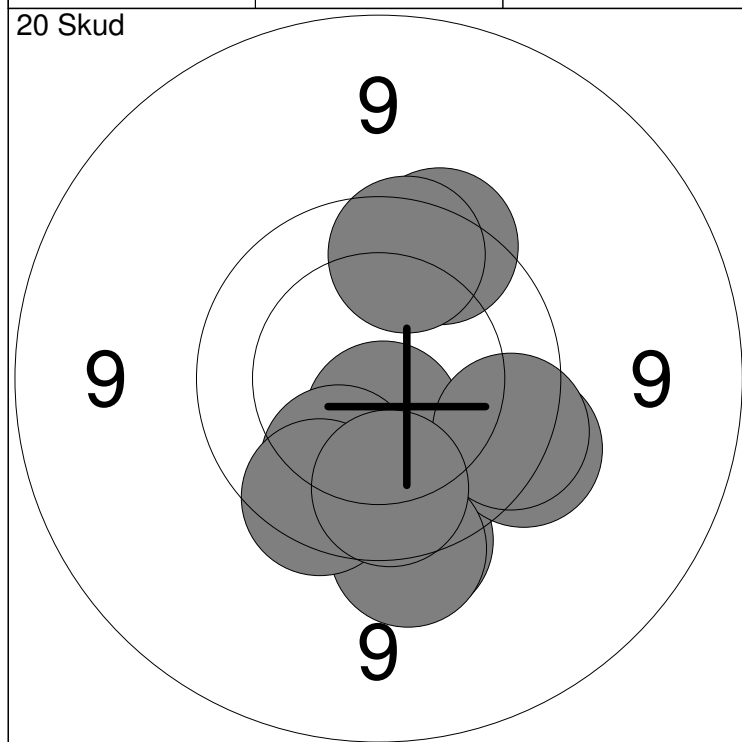

1: 9.6 ↓	6: 9.7 ↗	Serie 92.0
2: 9.6 →	7: 9.8 ↗	
3: *10.6 ↓	8: 9.7 →	Total 92.0
4: 10.0 ↓	9: 9.8 ↓	
5: 9.6 ↓	10: 9.9 ↓	

11: 9.8 ↓	16: 9.9 ↓	Serie 94.0
12: 10.3 ↓	17: 10.0 ↗	
13: *10.6 ↓	18: 9.4 ↗	Total 186.0
14: 9.9 ↓	19: 9.9 ←	
15: 9.8 →	20: 10.5 →	

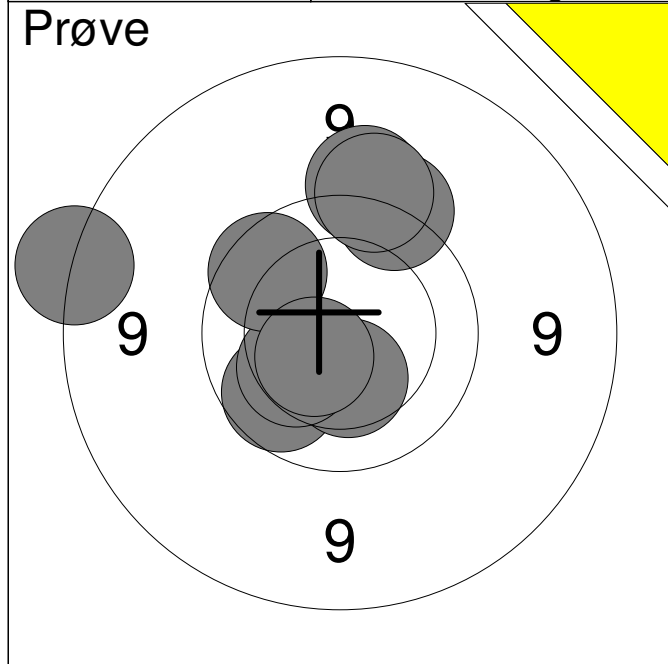

1:	9.9	↙
2:	9.6	↗
3:	10.4	↓
4:	10.2	↙
5:	9.4	↗
6:	9.5	↗
7:	9.8	↘
8:	8.7	↙
9:	*10.5	↙
Serie		83.0
Total		0.0

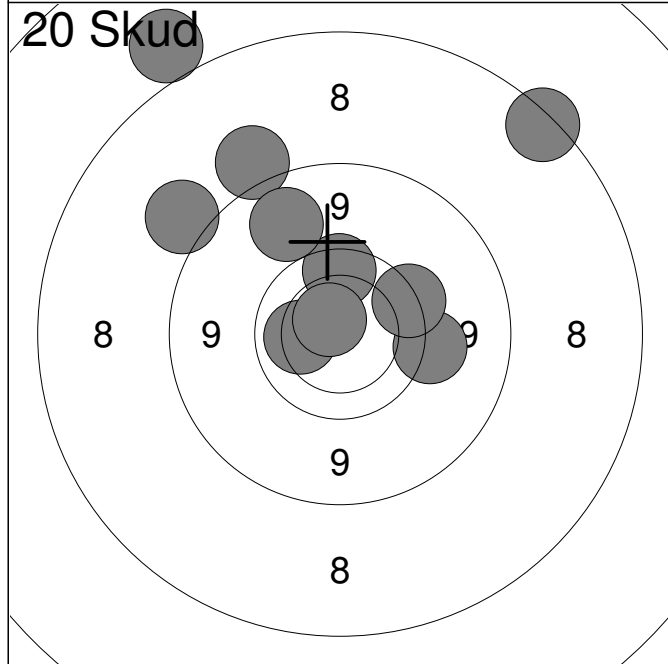

1:	8.5	↖
2:	9.5	→
3:	9.8	↑
4:	10.1	←
5:	9.6	↗
6:	8.5	↘
7:	9.1	↗
8:	7.4	↗
9:	*10.6	↗
10:	7.8	↗
Serie		86.0
Total		86.0

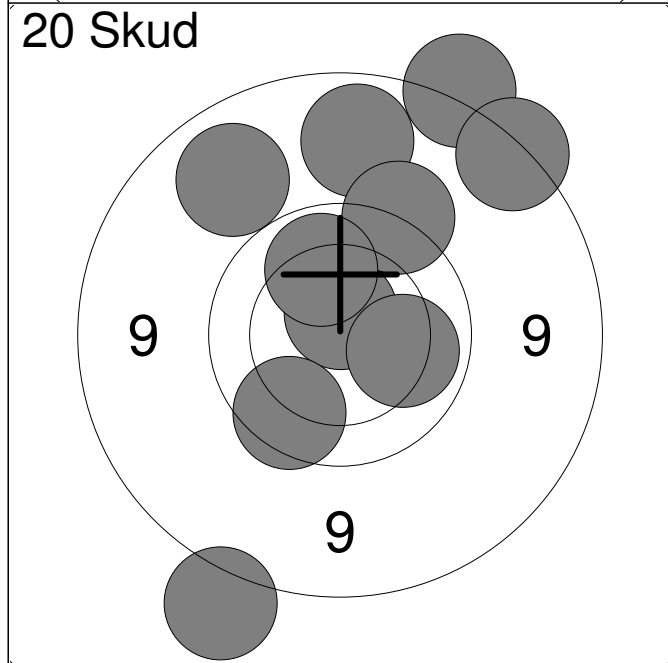

11:	*10.7	↑
12:	8.5	↙
13:	8.6	↗
14:	9.0	↑
15:	9.1	↘
16:	8.7	↗
17:	9.5	↗
18:	10.0	↑
19:	10.1	→
20:	9.8	↙
Serie		90.0
Total		176.0

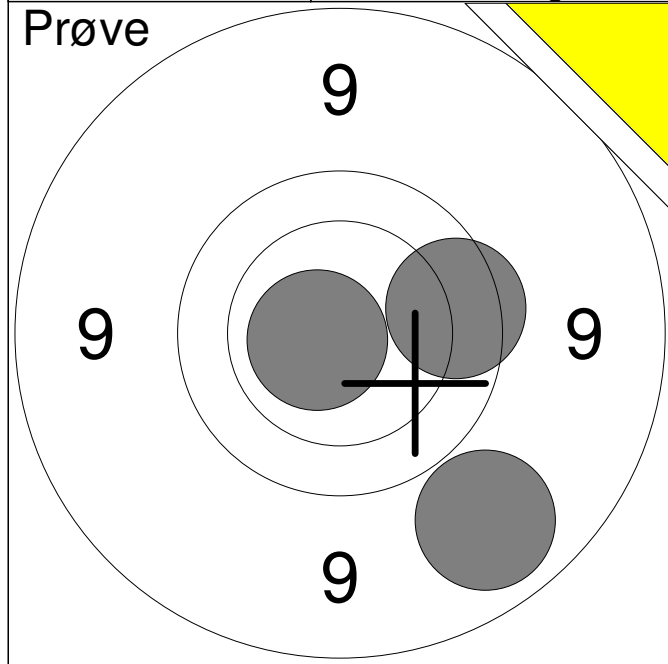

1:	9.8	→
2:	9.1	↓
3:	*10.7	←
Serie		28.0
Total		0.0

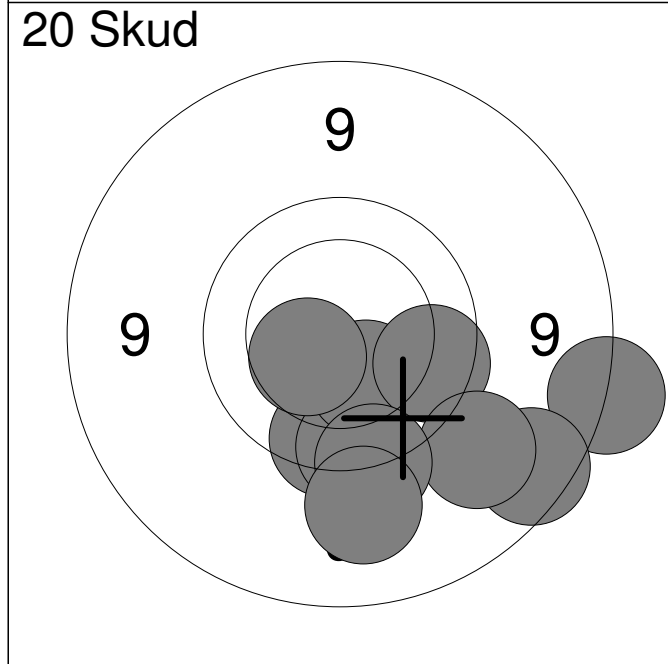

1:	9.8	↓
2:	9.7	↓
3:	8.7	→
4:	8.9	↓
5:	10.3	↓
6:	9.8	→
7:	9.2	↓
8:	9.5	↓
9:	9.3	↓
10:	10.4	←
Serie		90.0
Total		90.0

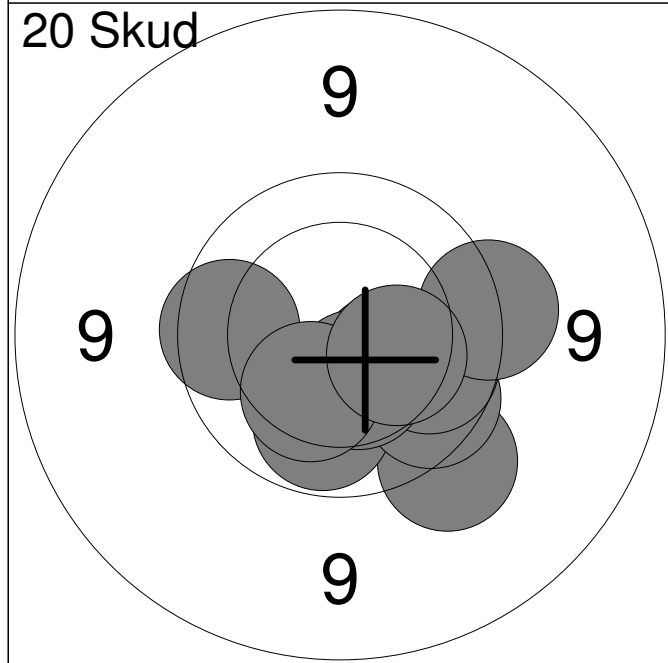

11:	9.5	↓
12:	10.0	↓
13:	10.4	↓
14:	9.8	↓
15:	9.9	→
16:	9.6	→
17:	10.4	↓
18:	9.8	←
19:	10.3	↓
20:	10.3	→
Serie		95.0
Total		185.0

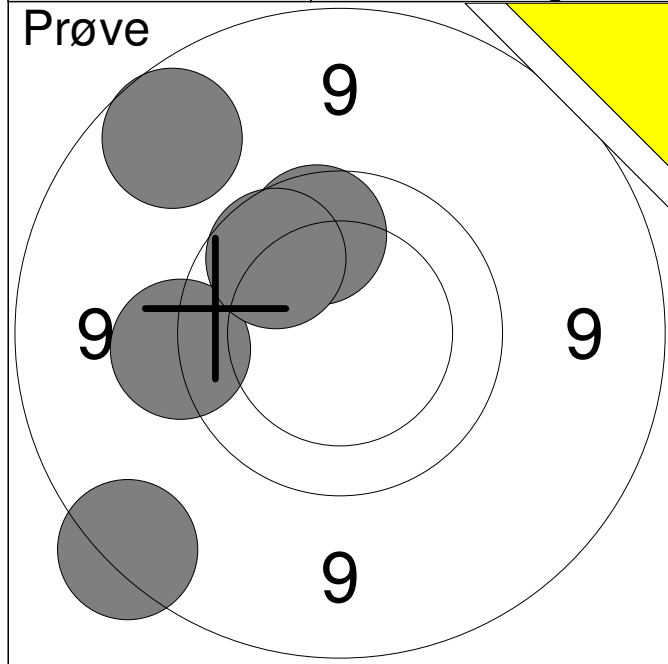

1:	8.8	↙
2:	9.9	↑
3:	9.5	←
4:	8.9	↗
5:	9.9	↗
Serie		43.0
Total		0.0

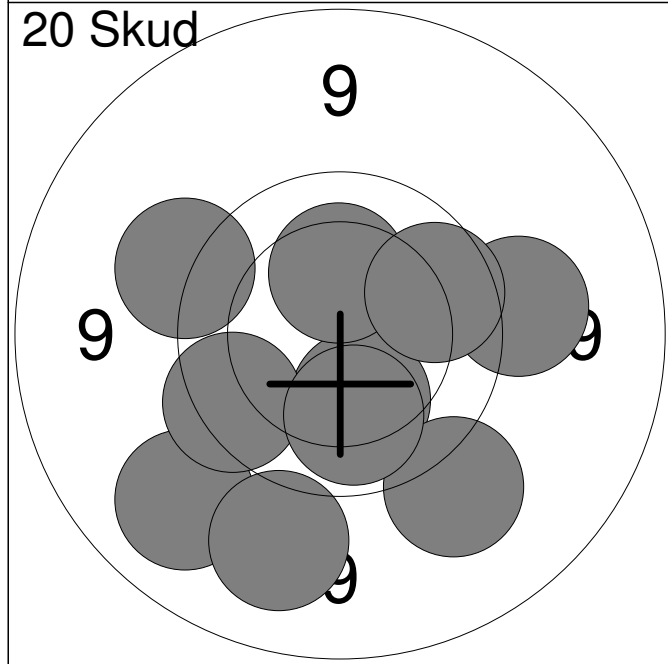

1:	10.2	↓
2:	9.1	↙
3:	9.3	↓
4:	9.7	↙
5:	10.3	↑
6:	9.5	↙
7:	9.4	→
8:	9.2	↓
9:	10.1	↓
10:	9.9	↗
Serie		93.0
Total		93.0

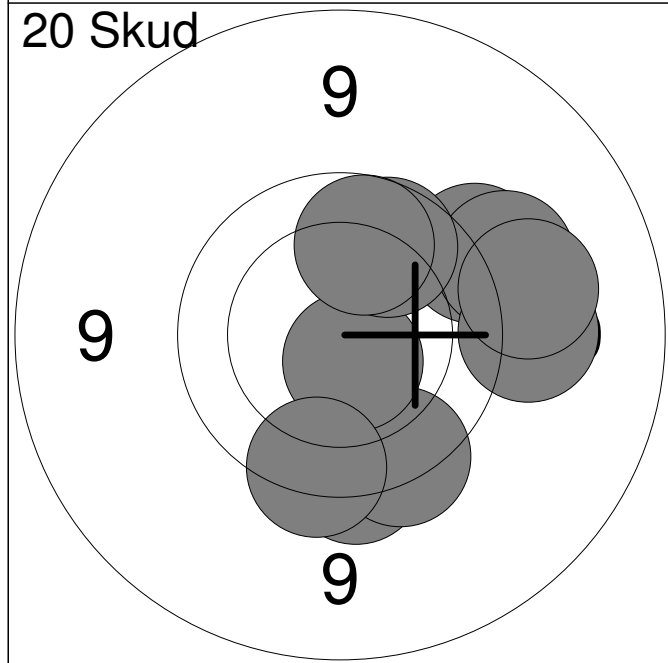

11:	9.7	↓
12:	9.6	↗
13:	9.7	↓
14:	9.4	↗
15:	*10.6	↓
16:	9.4	→
17:	9.9	↗
18:	9.9	↑
19:	9.3	→
20:	9.7	↓
Serie		91.0
Total		184.0

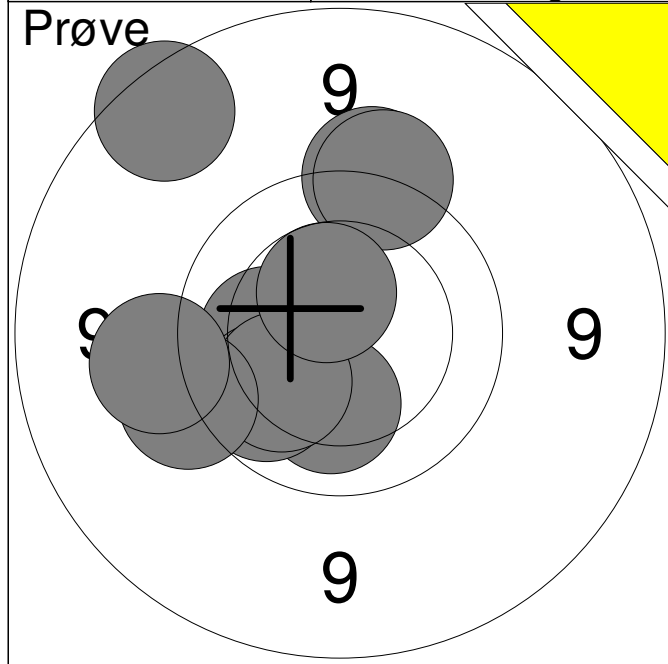

1:	10.2	←
2:	8.8	↗
3:	10.2	↓
4:	9.9	↙
5:	10.1	↙
6:	9.5	↑
7:	9.5	←
8:	9.4	←
9:	9.5	↑
10:	10.5	↑
Serie		93.0
Total		0.0

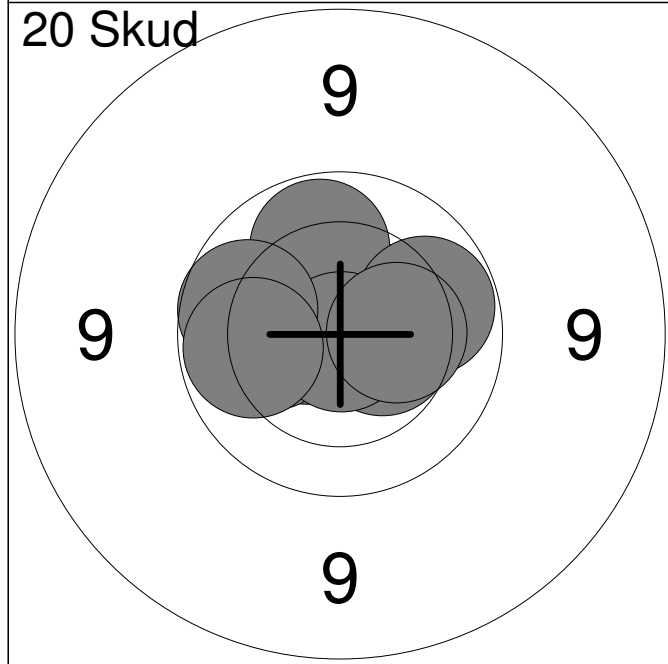

1:	*10.6	↑
2:	*10.6	←
3:	10.2	←
4:	10.0	↑
5:	10.0	→
6:	10.5	→
7:	*10.9	↓
8:	9.9	←
9:	10.0	←
10:	10.3	→
Serie		99.0
Total		99.0

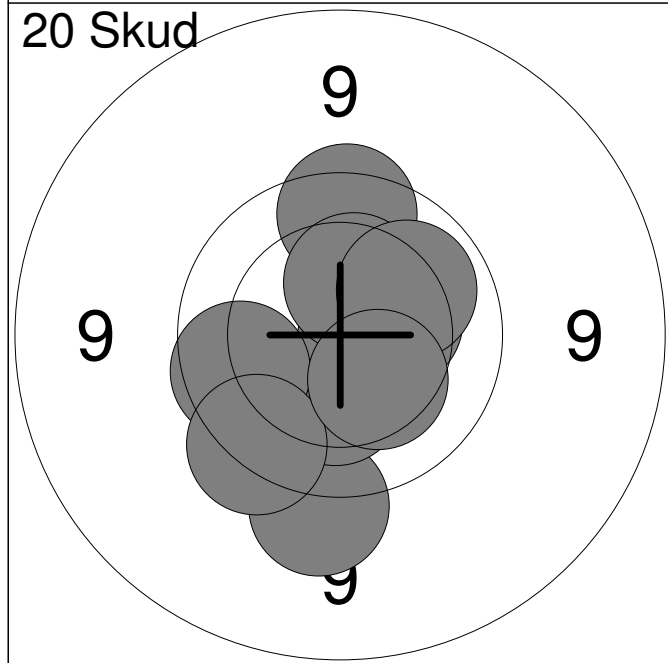

11:	9.5	↓
12:	*10.6	→
13:	10.4	→
14:	10.3	↓
15:	9.8	↑
16:	9.9	←
17:	9.7	↙
18:	10.4	↑
19:	10.1	↗
20:	10.3	↘
Serie		96.0
Total		195.0

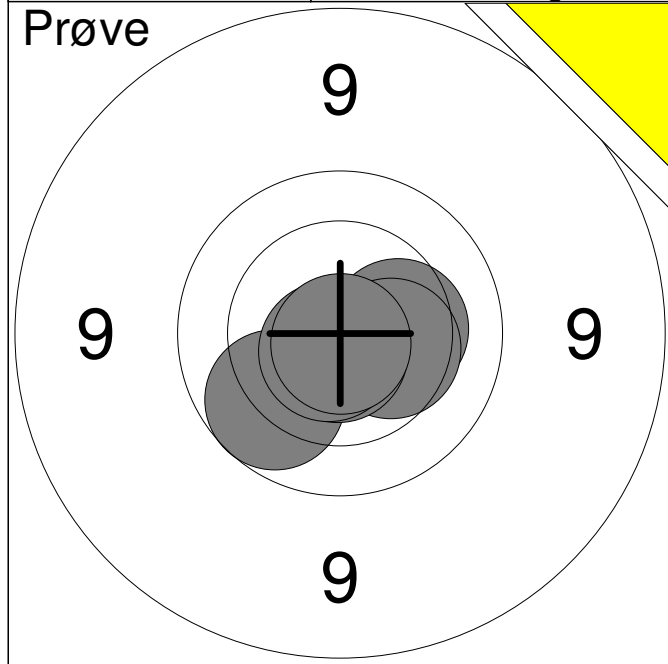

1:	9.9	↙
2:	10.3	→
3:	10.4	→
4:	*10.7	↓
5:	*10.7	↙
6:	*10.8	↓
Serie		59.0
Total		0.0

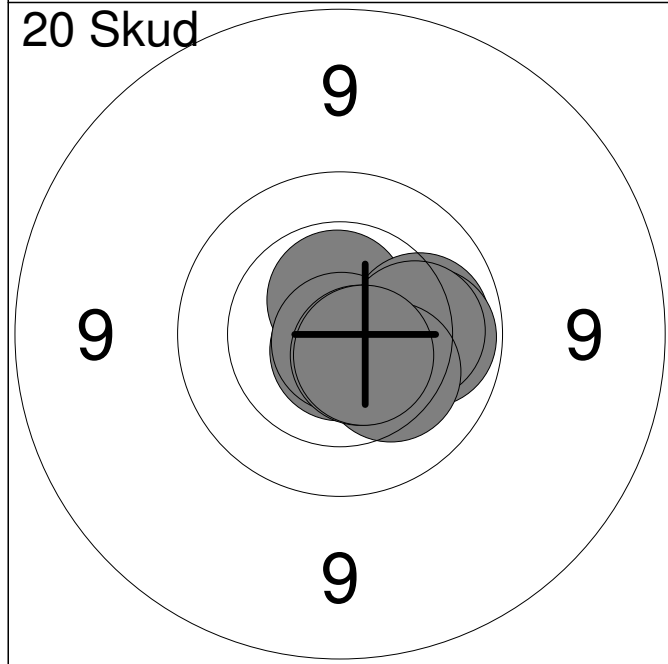

1:	*10.6	↑
2:	10.1	→
3:	10.3	→
4:	10.0	→
5:	*10.8	↓
6:	*10.9	↓
7:	10.1	→
8:	10.3	↙
9:	*10.6	↙
10:	*10.6	↙
Serie		100.0
Total		100.0

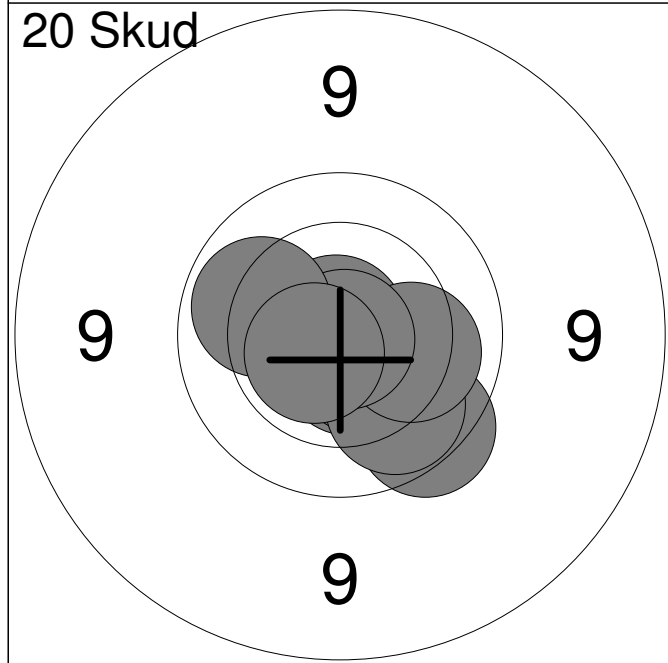

11:	9.7	↙
12:	10.3	↙
13:	*10.6	↙
14:	*10.5	↙
15:	10.0	↙
16:	*10.8	↗
17:	10.2	→
18:	*10.9	↙
19:	10.0	↗
20:	*10.6	↙
Serie		99.0
Total		199.0

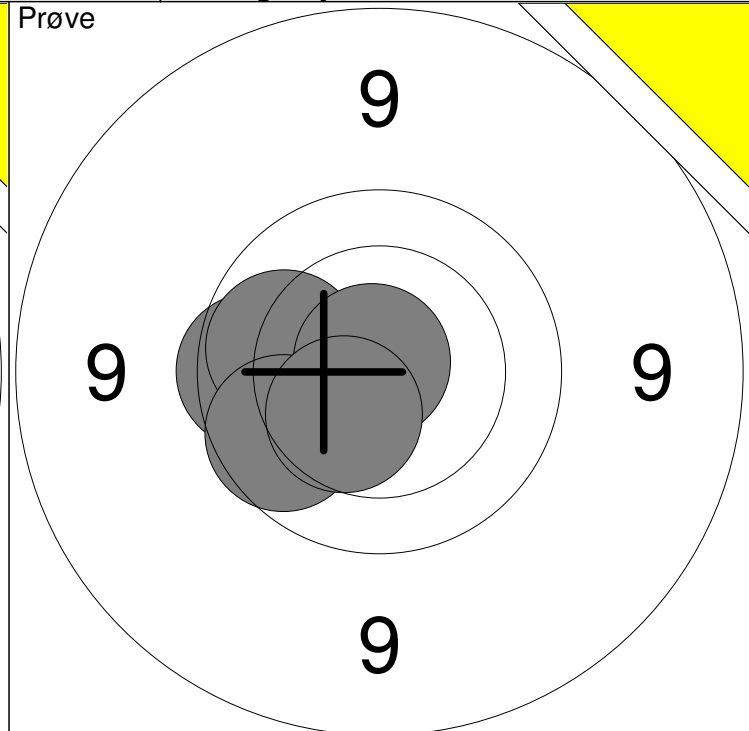
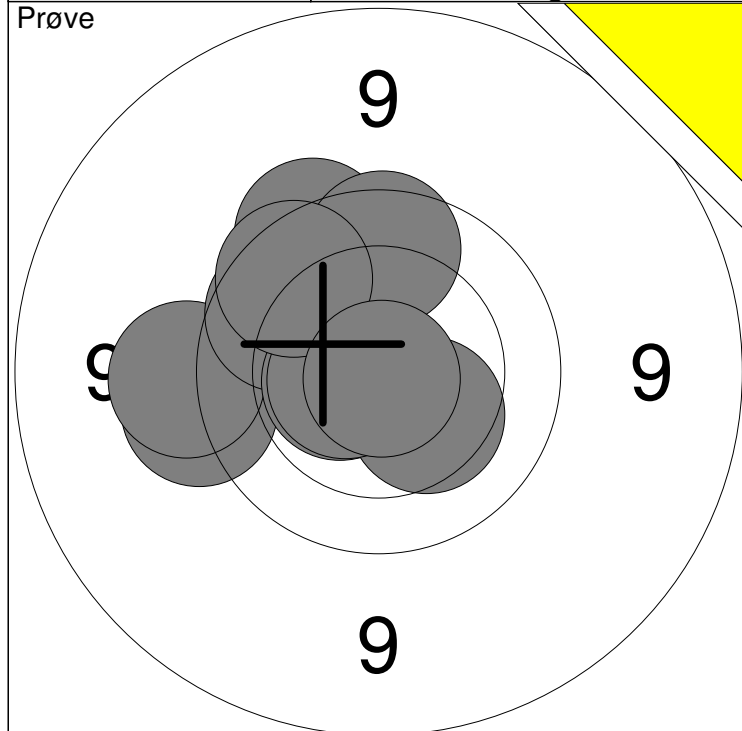

1: 9.7 ↗	6: *10.6 ←	Serie	94.0
2: 9.5 ←	7: 10.3 ↘		
3: 9.5 ←	8: *10.6 ←	Total	0.0
4: 9.8 ↑	9: 9.8 ↗		
5: 9.9 ↖	10: *10.9 ↘		

11: 10.1 ←	16: 10.4 ↘	Serie	58.0
12: 9.8 ←	13: 10.0 ←		
14: 9.9 ↖	15: *10.8 ↗	Total	0.0

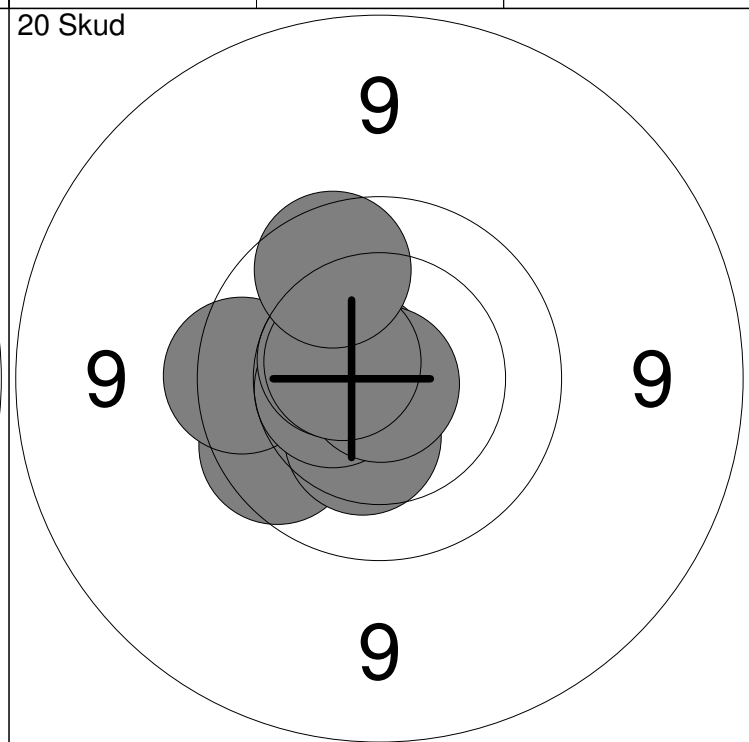
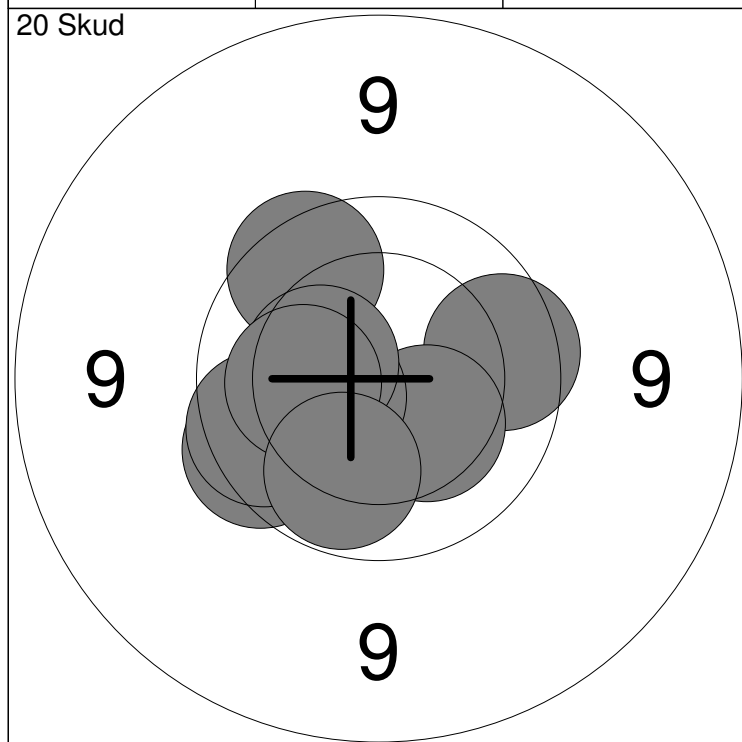

1: 10.1 ↖	6: 10.3 ↘	Serie	96.0
2: 9.8 ↖	7: 10.4 ←		
3: 9.8 ←	8: 10.4 ←	Total	96.0
4: 9.8 ↗	9: 10.2 ←		
5: 9.8 →	10: 10.0 ↘		

11: 10.5 ←	16: 10.5 ←	Serie	97.0
12: 9.9 ↖	17: 10.5 ↖		
13: 9.8 ←	18: *10.9 ↘	Total	193.0
14: *10.7 ↖	19: *10.6 ↖		
15: 10.4 ↘	20: 9.9 ↗		

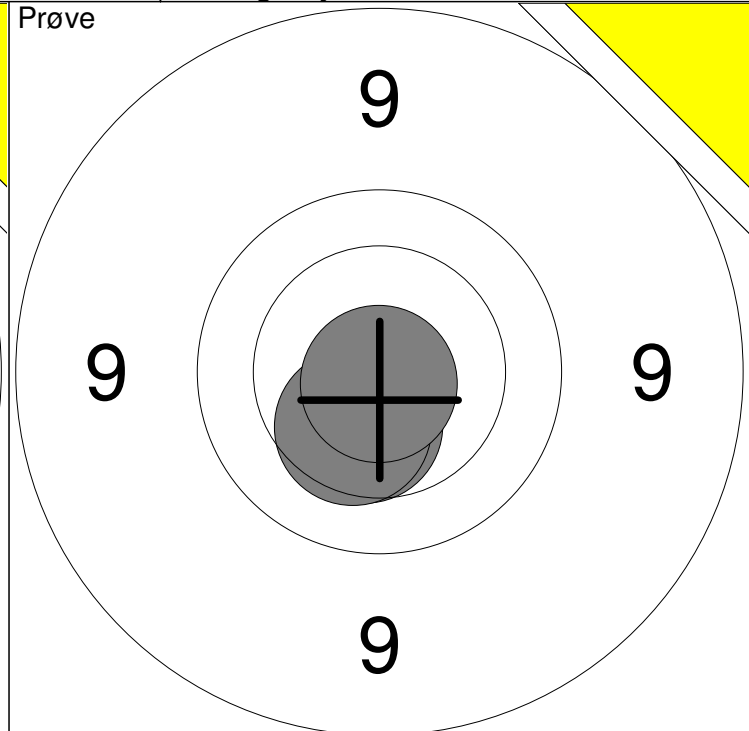
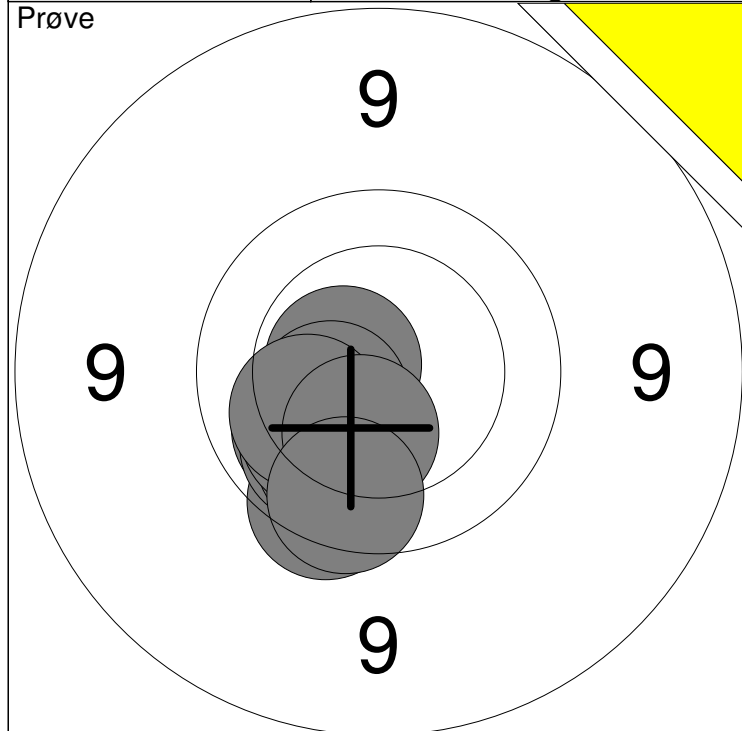

1: *10.6 ↙	6: 10.4 ↙	Serie	98.0
2: 9.8 ↓	7: 10.1 ↙		
3: 10.1 ↙	8: 10.2 ↙	Total	0.0
4: 10.0 ↓	9: 10.3 ↓		
5: 10.0 ↓	10: 9.8 ↓		

11: 10.4 ↓	Serie	30.0
12: 10.4 ↓		
13: *10.8 ↓	Total	0.0

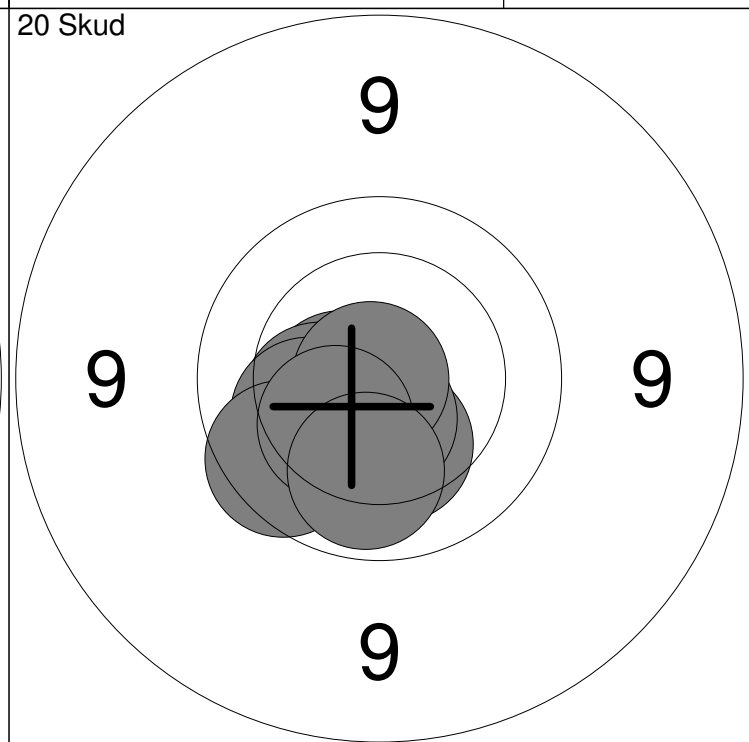
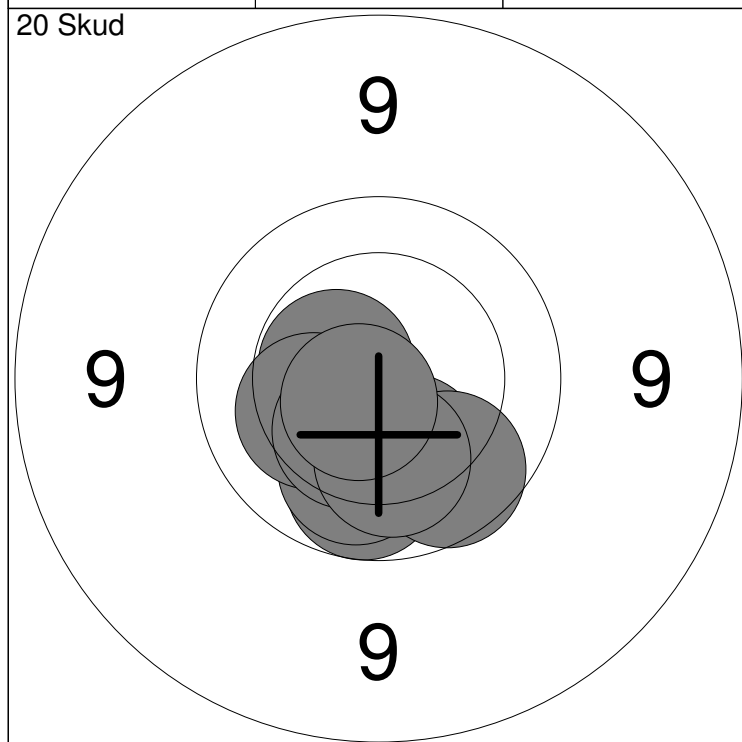

1: 9.9 ↓	6: 9.9 ↓	Serie	98.0
2: 10.3 ↓	7: 10.3 ↙		
3: 10.2 ↓	8: 10.4 ↓	Total	98.0
4: 10.1 ↓	9: 10.2 ↓		
5: *10.5 ↙	10: *10.7 ↙		

11: *10.6 ↙	16: 10.3 ↓	Serie	99.0
12: 10.3 ↙	17: *10.6 ↓		
13: 10.2 ↓	18: *10.9 ↙	Total	197.0
14: 10.2 ↙	19: 10.3 ↙		
15: 9.8 ↙	20: 10.0 ↓		

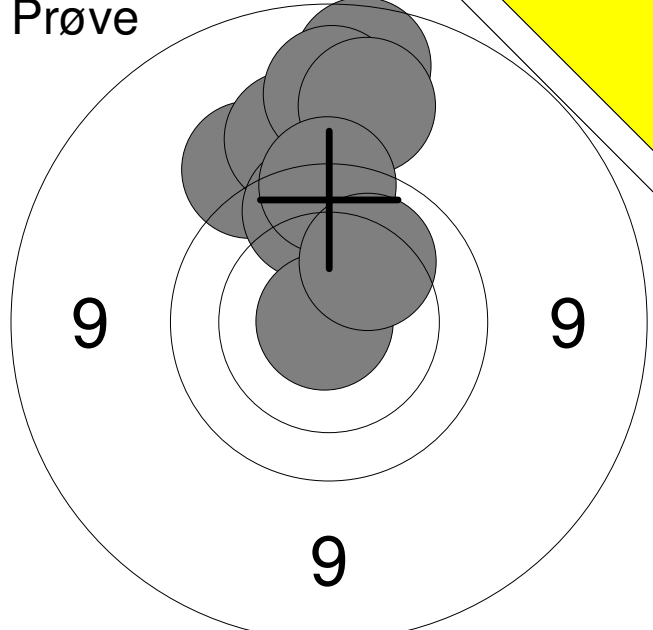
<p>Prøve</p> 	<table style="width:100%; border-collapse: collapse;"> <tr><td>1:</td><td>8.9</td><td>↑</td></tr> <tr><td>2:</td><td>9.4</td><td>↖</td></tr> <tr><td>3:</td><td>9.3</td><td>↑</td></tr> <tr><td>4:</td><td>9.1</td><td>↑</td></tr> <tr><td>5:</td><td>9.9</td><td>↑</td></tr> <tr><td>6:</td><td>9.8</td><td>↑</td></tr> <tr><td>7:</td><td>9.1</td><td>↑</td></tr> <tr><td>8:</td><td>9.7</td><td>↑</td></tr> <tr><td>9:</td><td>*10.9</td><td>←</td></tr> <tr><td>10:</td><td>10.2</td><td>↗</td></tr> <tr><td colspan="2">Serie</td><td>91.0</td></tr> <tr><td colspan="2">Total</td><td>0.0</td></tr> </table>	1:	8.9	↑	2:	9.4	↖	3:	9.3	↑	4:	9.1	↑	5:	9.9	↑	6:	9.8	↑	7:	9.1	↑	8:	9.7	↑	9:	*10.9	←	10:	10.2	↗	Serie		91.0	Total		0.0
1:	8.9	↑																																			
2:	9.4	↖																																			
3:	9.3	↑																																			
4:	9.1	↑																																			
5:	9.9	↑																																			
6:	9.8	↑																																			
7:	9.1	↑																																			
8:	9.7	↑																																			
9:	*10.9	←																																			
10:	10.2	↗																																			
Serie		91.0																																			
Total		0.0																																			

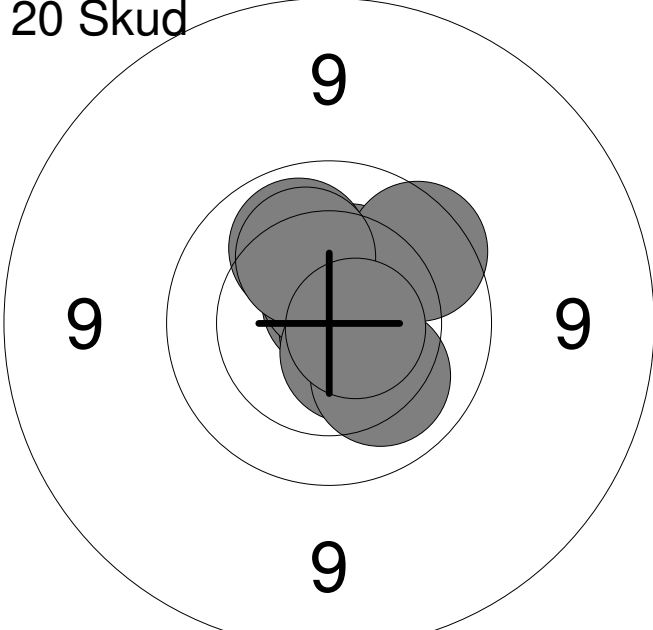
<p>20 Skud</p> 	<table style="width:100%; border-collapse: collapse;"> <tr><td>1:</td><td>*10.7</td><td>↑</td></tr> <tr><td>2:</td><td>*10.7</td><td>→</td></tr> <tr><td>3:</td><td>10.4</td><td>↗</td></tr> <tr><td>4:</td><td>*10.5</td><td>↑</td></tr> <tr><td>5:</td><td>10.1</td><td>↑</td></tr> <tr><td>6:</td><td>*10.6</td><td>↘</td></tr> <tr><td>7:</td><td>9.8</td><td>↗</td></tr> <tr><td>8:</td><td>10.2</td><td>↘</td></tr> <tr><td>9:</td><td>10.2</td><td>↑</td></tr> <tr><td>10:</td><td>*10.7</td><td>→</td></tr> <tr><td colspan="2">Serie</td><td>99.0</td></tr> <tr><td colspan="2">Total</td><td>99.0</td></tr> </table>	1:	*10.7	↑	2:	*10.7	→	3:	10.4	↗	4:	*10.5	↑	5:	10.1	↑	6:	*10.6	↘	7:	9.8	↗	8:	10.2	↘	9:	10.2	↑	10:	*10.7	→	Serie		99.0	Total		99.0
1:	*10.7	↑																																			
2:	*10.7	→																																			
3:	10.4	↗																																			
4:	*10.5	↑																																			
5:	10.1	↑																																			
6:	*10.6	↘																																			
7:	9.8	↗																																			
8:	10.2	↘																																			
9:	10.2	↑																																			
10:	*10.7	→																																			
Serie		99.0																																			
Total		99.0																																			

<p>20 Skud</p> 	<table style="width:100%; border-collapse: collapse;"> <tr><td>11:</td><td>10.4</td><td>↗</td></tr> <tr><td>12:</td><td>9.8</td><td>↑</td></tr> <tr><td>13:</td><td>10.1</td><td>↗</td></tr> <tr><td>14:</td><td>10.4</td><td>↗</td></tr> <tr><td>15:</td><td>10.2</td><td>↑</td></tr> <tr><td>16:</td><td>10.4</td><td>↖</td></tr> <tr><td>17:</td><td>*10.5</td><td>↑</td></tr> <tr><td>18:</td><td>*10.6</td><td>↖</td></tr> <tr><td>19:</td><td>10.3</td><td>↘</td></tr> <tr><td>20:</td><td>10.1</td><td>↗</td></tr> <tr><td colspan="2">Serie</td><td>99.0</td></tr> <tr><td colspan="2">Total</td><td>198.0</td></tr> </table>	11:	10.4	↗	12:	9.8	↑	13:	10.1	↗	14:	10.4	↗	15:	10.2	↑	16:	10.4	↖	17:	*10.5	↑	18:	*10.6	↖	19:	10.3	↘	20:	10.1	↗	Serie		99.0	Total		198.0
11:	10.4	↗																																			
12:	9.8	↑																																			
13:	10.1	↗																																			
14:	10.4	↗																																			
15:	10.2	↑																																			
16:	10.4	↖																																			
17:	*10.5	↑																																			
18:	*10.6	↖																																			
19:	10.3	↘																																			
20:	10.1	↗																																			
Serie		99.0																																			
Total		198.0																																			

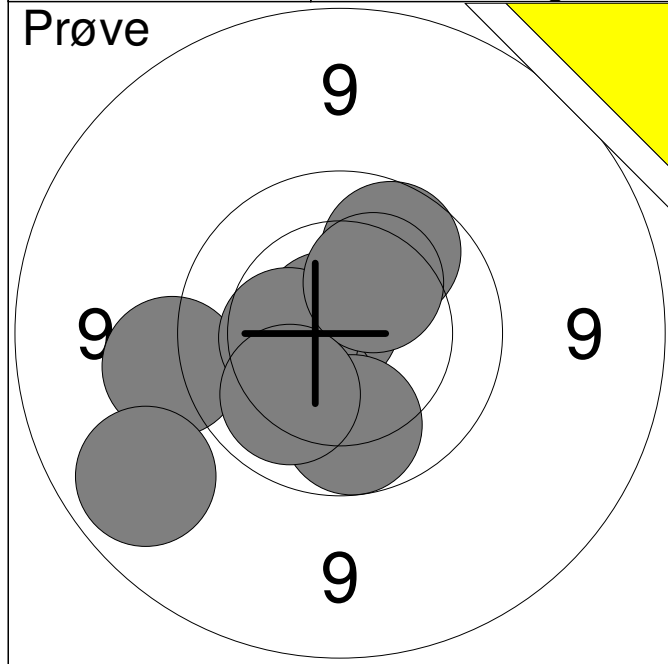

1:	9.5	←
2:	9.0	↙
3:	9.9	↗
4:	*10.7	←
5:	*10.8	↗
6:	10.2	↘
7:	10.4	←
8:	10.0	↓
9:	10.3	↗
10:	10.1	↙
Serie		97.0
Total		0.0

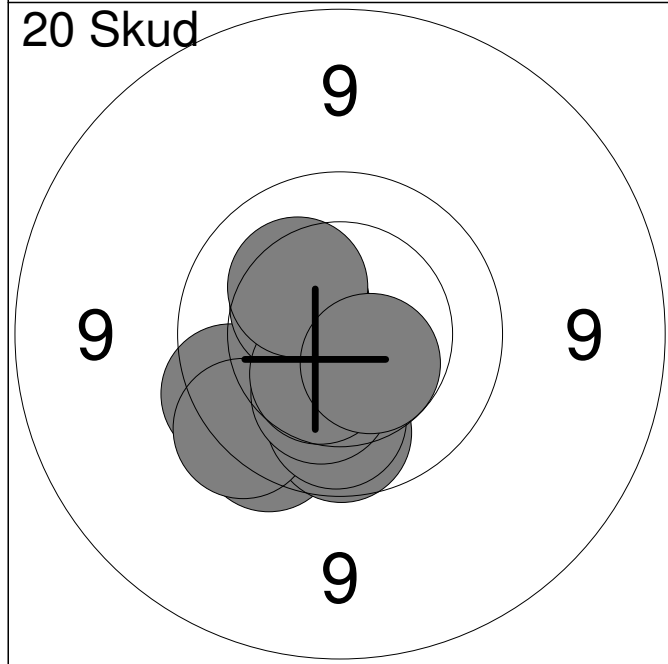

1:	9.7	↘
2:	9.8	←
3:	9.9	↓
4:	9.7	↙
5:	10.0	↓
6:	10.3	↘
7:	10.4	↗
8:	10.5	↘
9:	10.3	↗
10:	*10.5	↘
Serie		96.0
Total		96.0

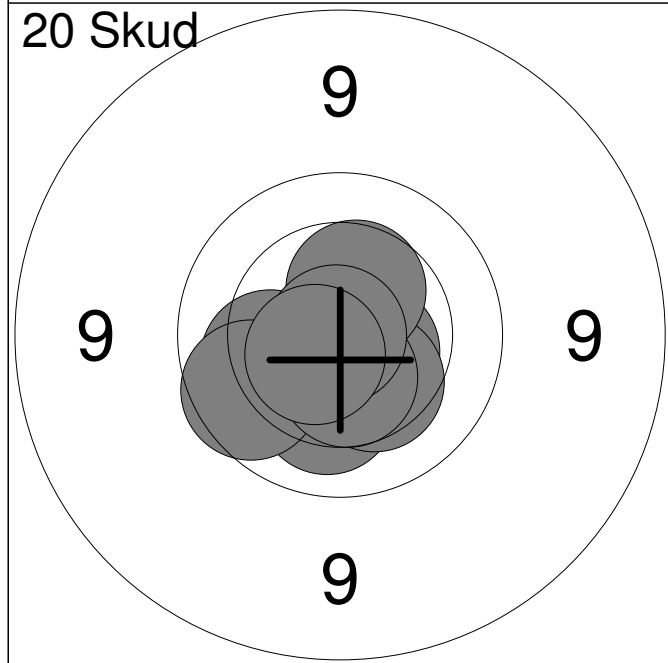

11:	*10.5	↘
12:	10.2	←
13:	10.2	↓
14:	*10.6	→
15:	9.9	↙
16:	10.3	↘
17:	10.4	↗
18:	10.5	↓
19:	*10.9	←
20:	*10.6	↙
Serie		99.0
Total		195.0

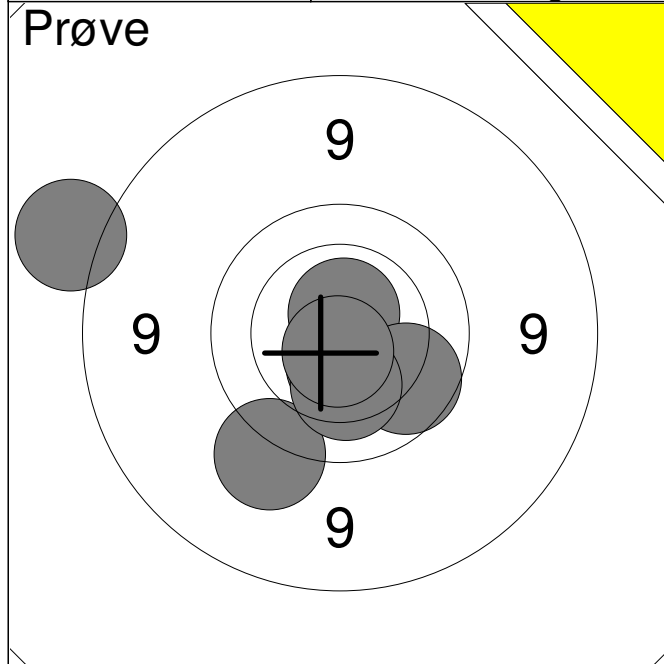

1:	9.4	↙
2:	8.5	↖
3:	*10.7	↗
4:	*10.5	↘
5:	9.9	↘
6:	10.3	↘
7:	*10.7	↘
Serie		66.0
Total		0.0

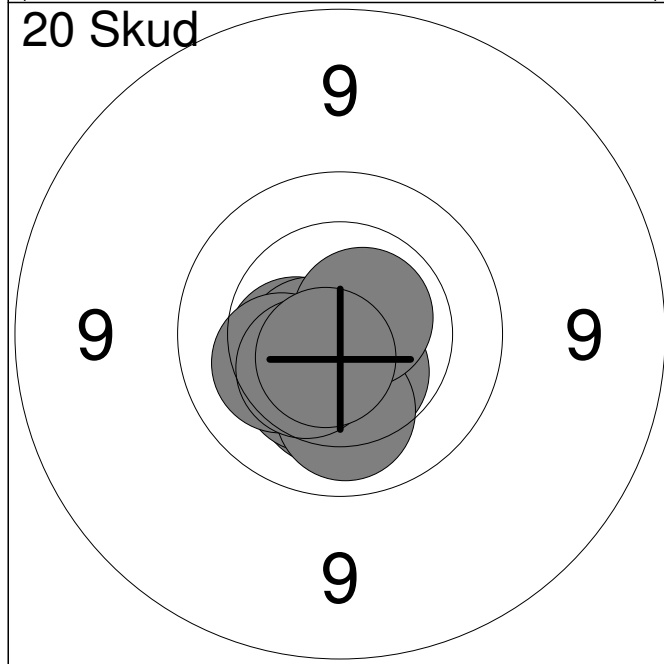

1:	10.5	↖
2:	10.3	↘
3:	*10.6	↖
4:	10.3	↘
5:	*10.5	↘
6:	10.1	↘
7:	10.2	↖
8:	*10.6	↗
9:	10.4	↘
10:	*10.7	↘
Serie		100.0
Total		100.0

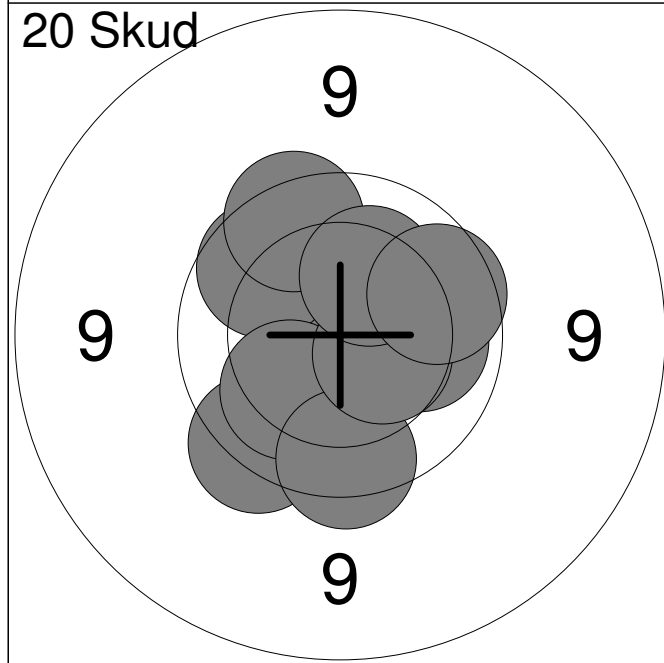

11:	10.1	↗
12:	9.9	↗
13:	9.7	↘
14:	10.1	→
15:	10.1	↘
16:	9.8	↘
17:	10.5	↗
18:	9.8	↗
19:	10.2	↗
20:	9.9	→
Serie		95.0
Total		195.0

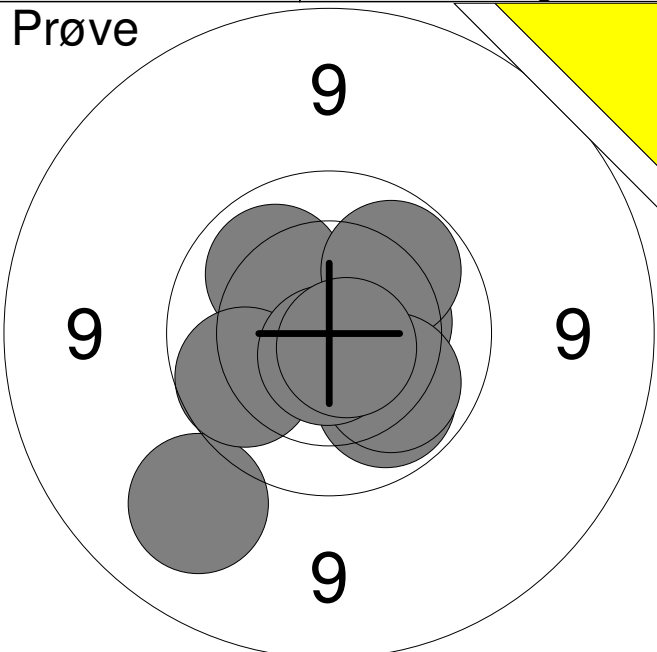
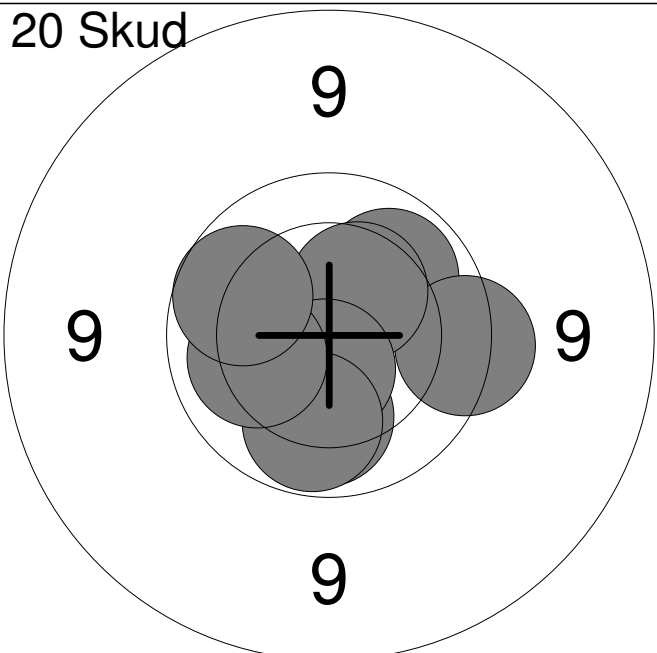
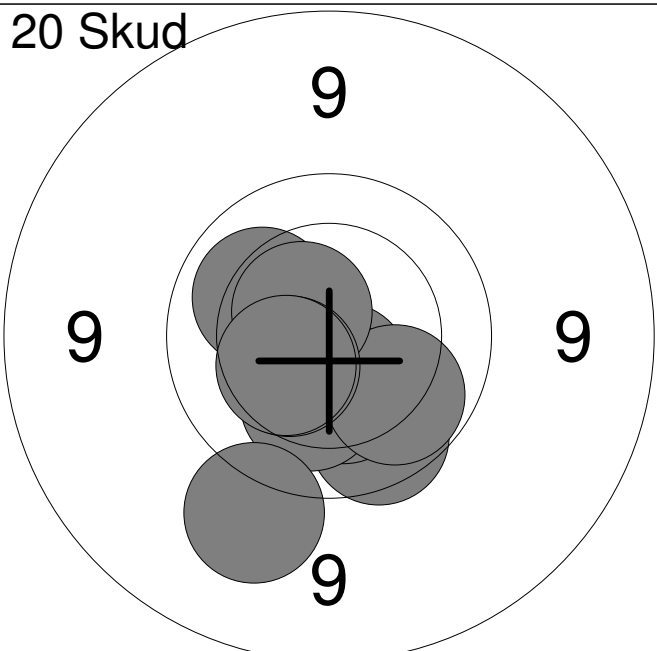
Hold	Skive	Niels Løjengaard Hermansen	
3	2	15m	Mou & Omegns Skf. MB3
1/3 - 3/3 2013	NM 15 meter Ungdom 2013	Aalborg Skyttekreds	
Prøve 	1:	*10.7	↘
	2:	10.0	↘
	3:	9.2	↘
	4:	10.4	→
	5:	10.1	↗
	6:	9.9	↙
	7:	10.0	↗
	8:	10.1	↘
	9:	*10.7	↘
	10:	*10.7	↘
	Serie		98.0
Total		0.0	
20 Skud 	1:	10.1	↓
	2:	*10.7	←
	3:	*10.7	↓
	4:	10.1	↗
	5:	9.7	→
	6:	10.4	↗
	7:	*10.6	↓
	8:	10.0	↓
	9:	10.1	←
	10:	9.9	↗
	Serie		98.0
Total		98.0	
20 Skud 	11:	9.8	↘
	12:	*10.5	↘
	13:	10.1	↗
	14:	10.3	↘
	15:	10.2	↘
	16:	10.0	↘
	17:	9.3	↘
	18:	*10.6	↗
	19:	10.4	↙
	20:	10.4	↙
	Serie		98.0
Total		196.0	

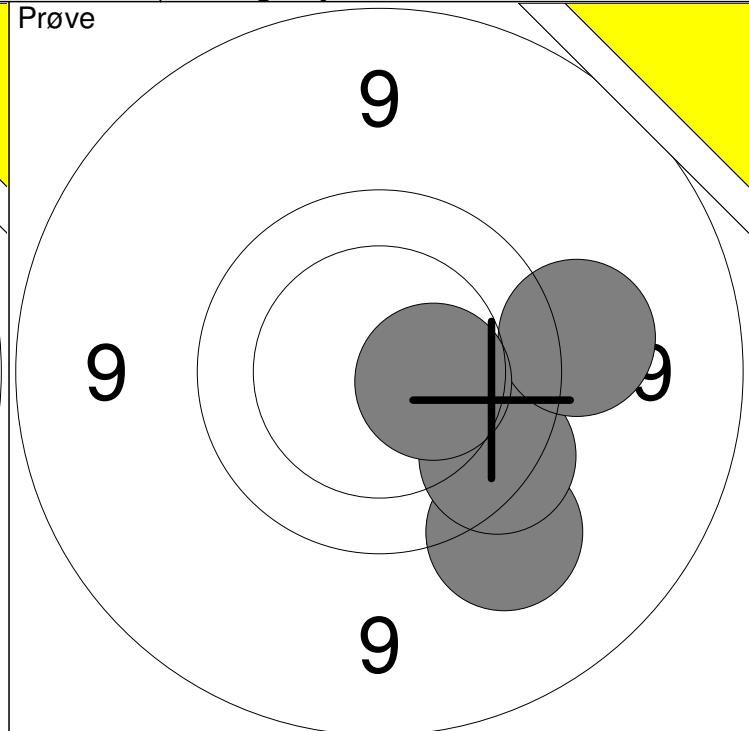
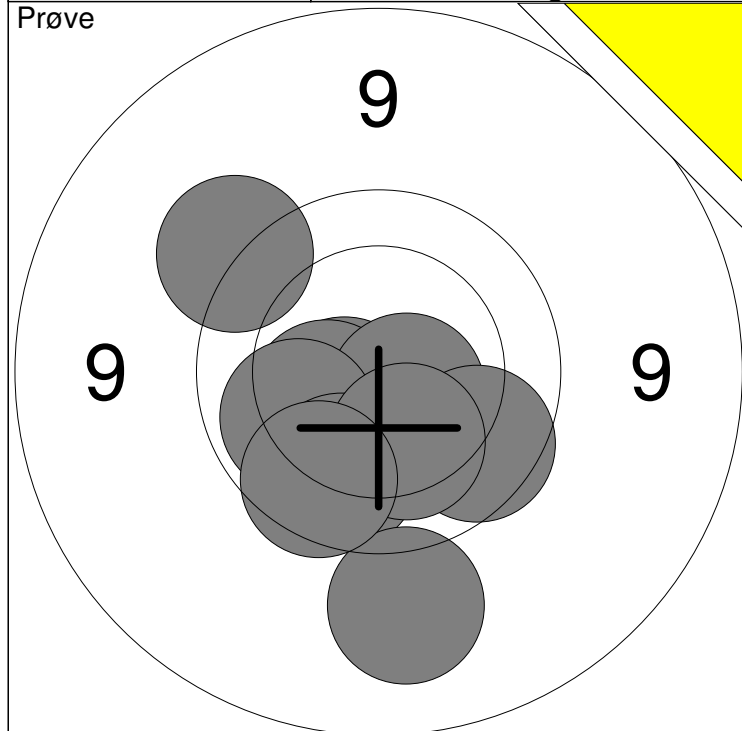

1: *10.6 ↙	6: 9.2 ↓	Serie	95.0
2: 10.4 ↙	7: 9.8 ↘		
3: *10.6 ↘	8: 10.2 ↓	Total	0.0
4: 10.1 ↙	9: 9.5 ↗		
5: 9.9 ↓	10: 9.8 ↓		

11: 9.4 ↓	Serie	37.0
12: 9.7 ↘		
13: 9.4 →	Total	0.0
14: 10.4 →		

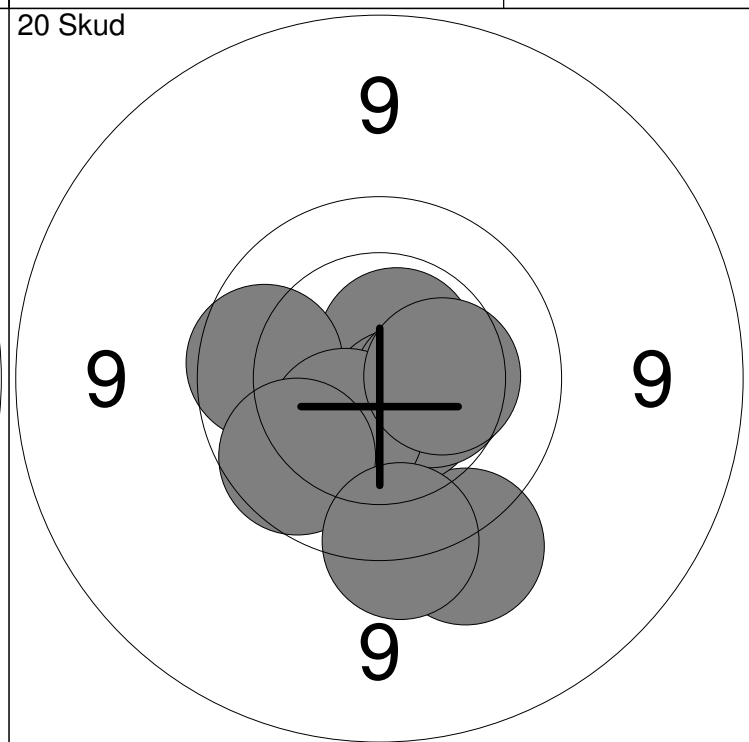
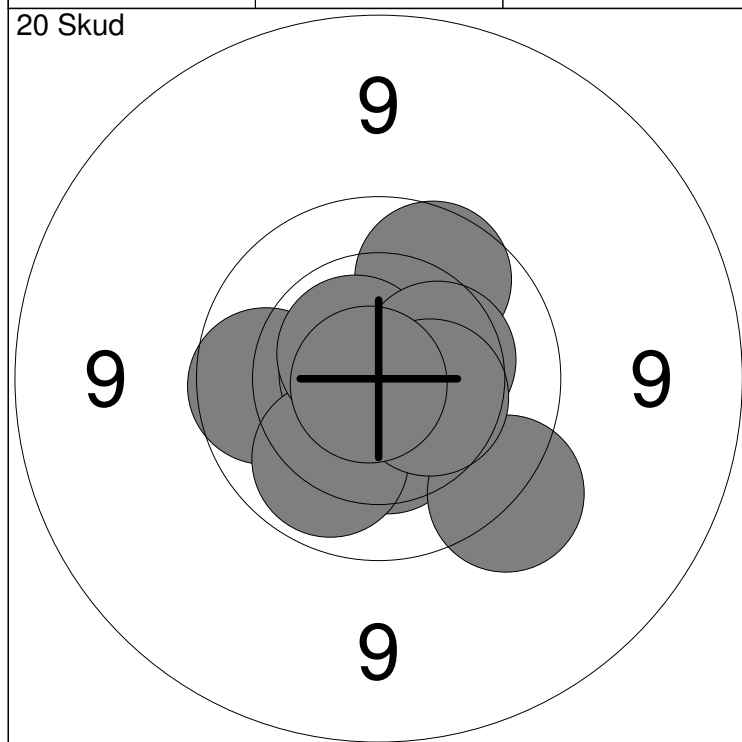

1: 10.4 ↓	6: *10.6 ↖	Serie	97.0
2: 9.9 ↗	7: 9.6 ↓		
3: 9.9 ←	8: 10.4 →	Total	97.0
4: *10.7 ↖	9: 10.4 →		
5: 10.0 ↓	10: *10.8 ↖		

11: 9.5 ↓	16: 10.4 →	Serie	96.0
12: 10.2 ↙	17: 10.4 ↓		
13: *10.6 ↗	18: 10.3 →	Total	193.0
14: 9.9 ←	19: 9.9 ↙		
15: *10.6 ↘	20: 9.6 ↓		

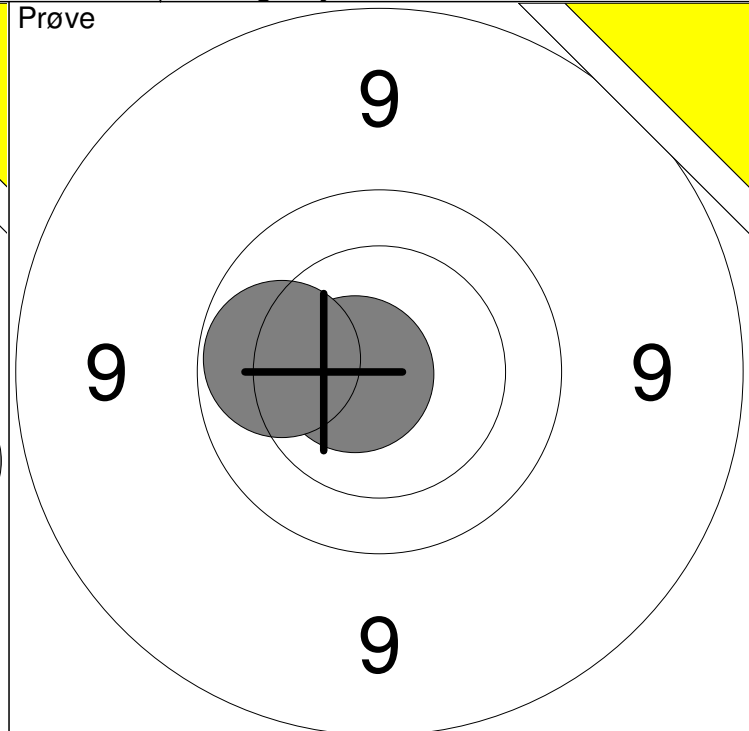
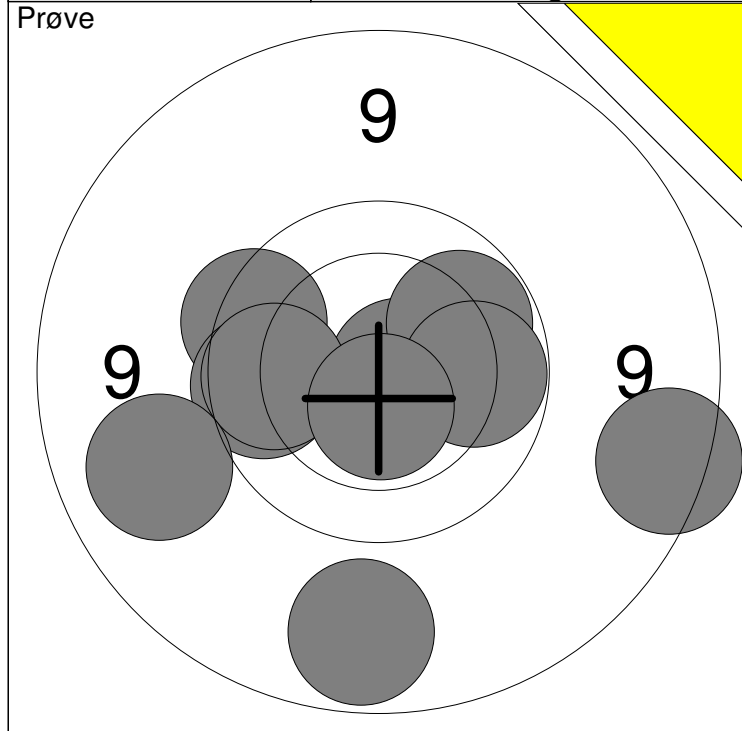

1: 9.0 ↓	6: 9.9 ←	Serie	93.0
2: *10.7 →	7: 8.8 →		
3: 9.7 ←	8: 10.0 →	Total	0.0
4: 10.0 ↗	9: *10.6 ↓		
5: 9.8 ←	10: 9.1 ←		

11: *10.7 ←	Serie	20.0
12: 10.0 ←		
Total		0.0

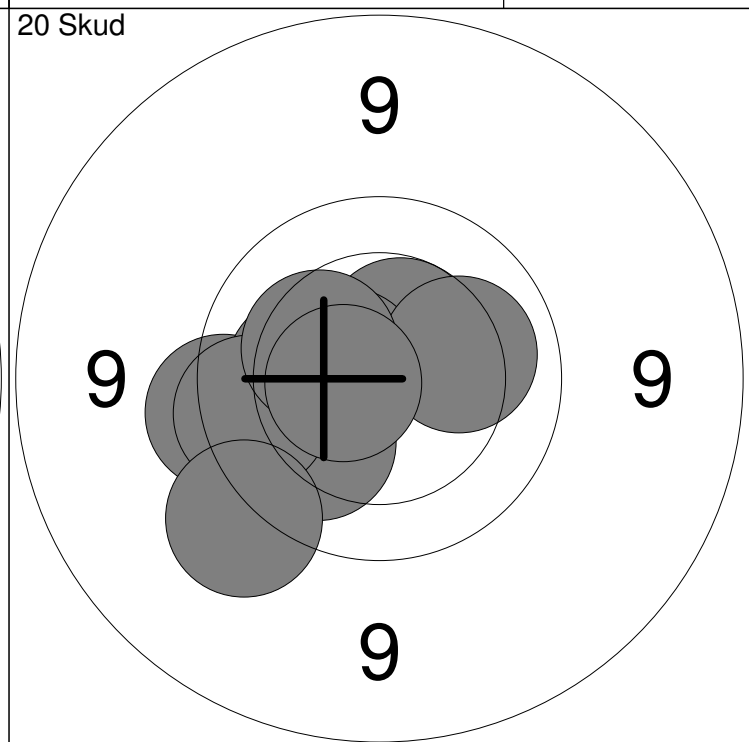
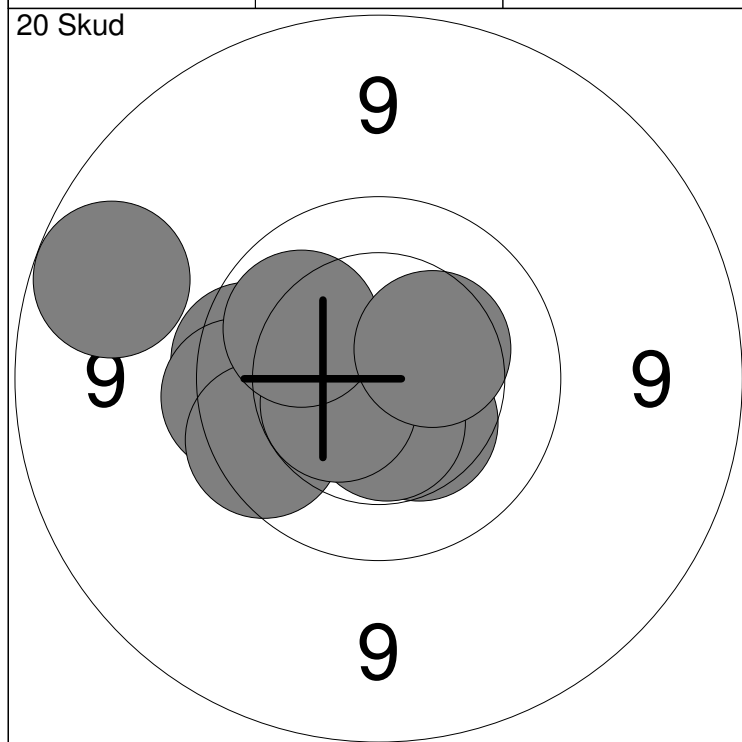

1: 10.4 ↓	6: 9.8 ←	Serie	96.0
2: 9.0 ←	7: *10.5 ↓		
3: 9.8 ←	8: *10.5 ←	Total	96.0
4: 9.7 ←	9: 10.1 ←		
5: 10.3 ←	10: 10.4 ↗		

11: 9.6 ←	16: 10.2 →	Serie	97.0
12: *10.5 ↗	17: 9.8 ←		
13: 10.1 ↓	18: 9.5 ↓	Total	193.0
14: *10.6 ←	19: 10.3 ←		
15: 10.2 ←	20: *10.6 ←		

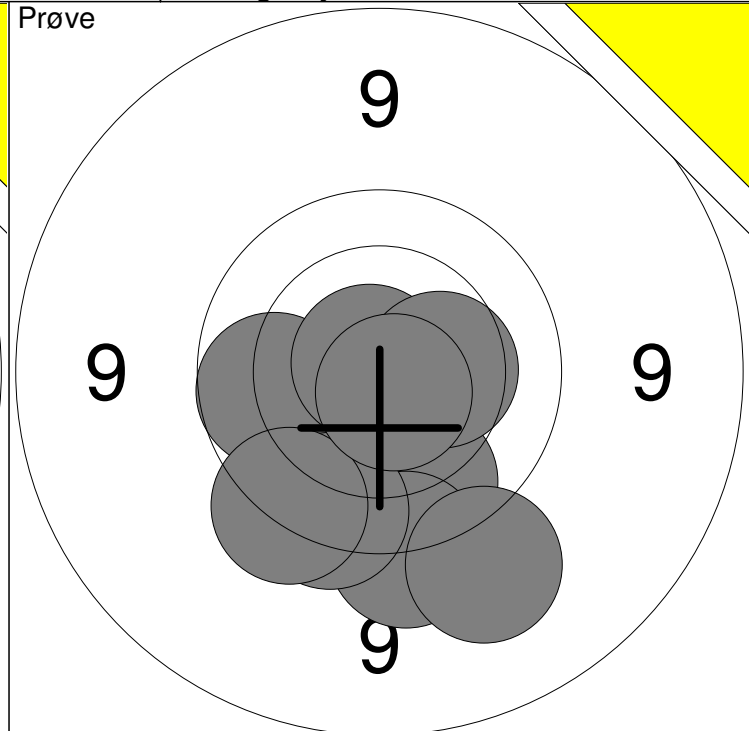
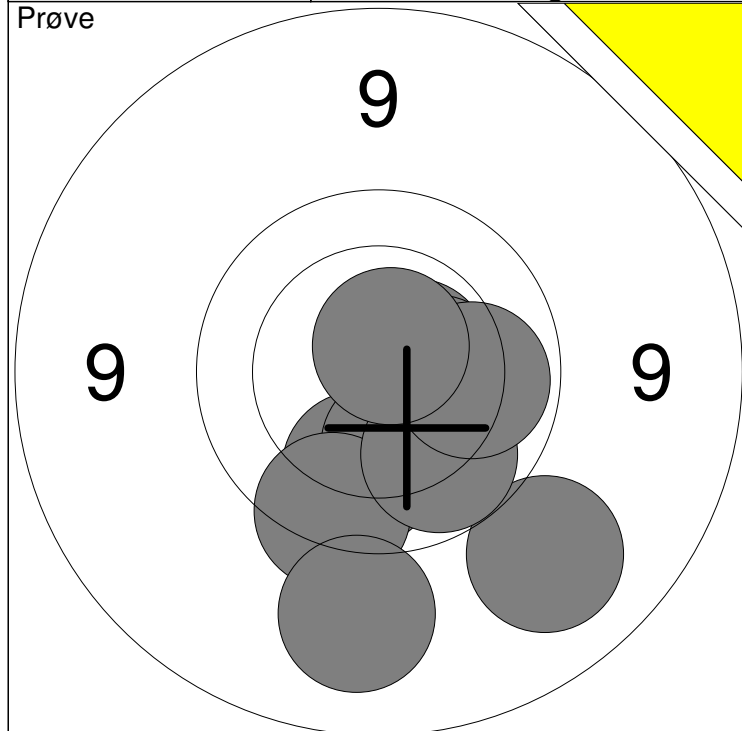

1: 10.0 ↓	6: *10.6 →	Serie	97.0
2: 10.2 ↓	7: 10.4 →		
3: 9.7 ↓	8: 10.0 ↓	Total	0.0
4: 9.2 ↓	9: 10.0 →		
5: 9.2 ↓	10: *10.7 ↑		

11: 10.3 ←	16: 9.7 ↓	Serie	94.0
12: 9.9 ↓	17: *10.8 ↘		
13: 9.5 ↓	18: 9.6 ↓	Total	0.0
14: 9.9 ←	19: 10.4 →		
15: 9.3 ↓	20: *10.7 ↓		

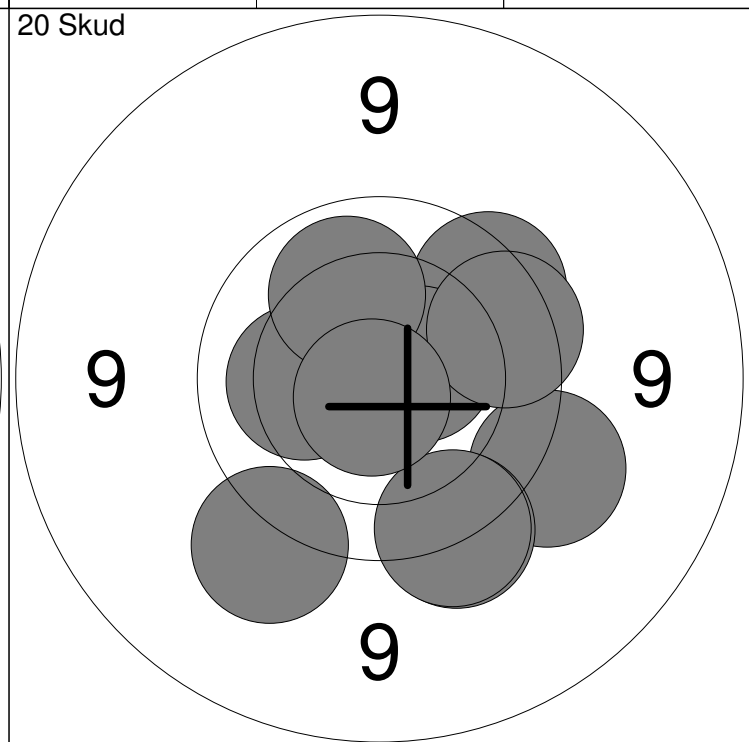
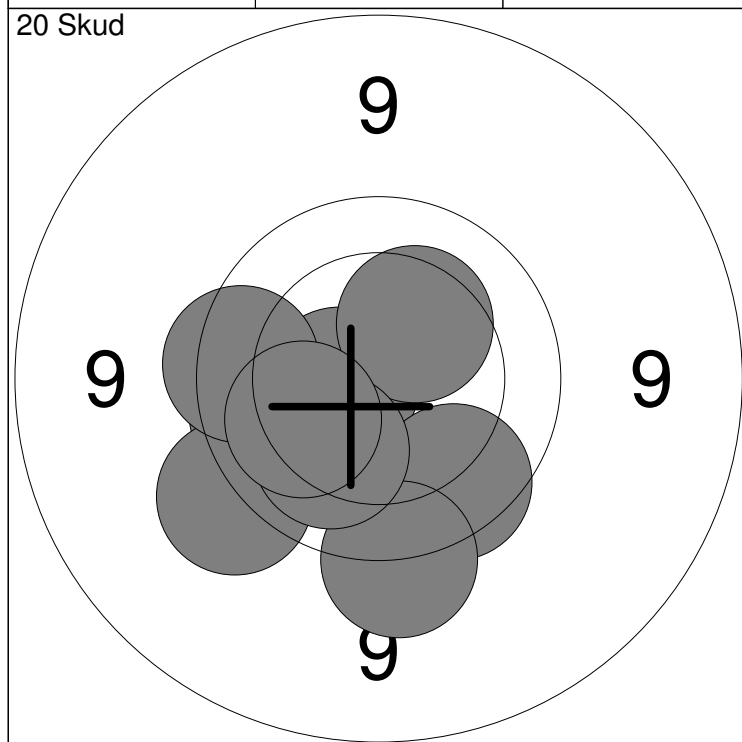

1: 10.1 ←	6: 9.5 ←	Serie	95.0
2: *10.6 ←	7: 10.3 ↑		
3: 9.8 ↓	8: 10.1 ↓	Total	95.0
4: 9.5 ↓	9: 9.8 ←		
5: 9.9 ←	10: 10.1 ←		

11: 9.7 ↗	16: 9.6 ↓	Serie	94.0
12: 9.5 ↘	17: 9.6 ↓		
13: 10.2 ←	18: 9.8 →	Total	189.0
14: 9.4 ↓	19: 10.1 ↑		
15: *10.6 →	20: *10.8 ↓		

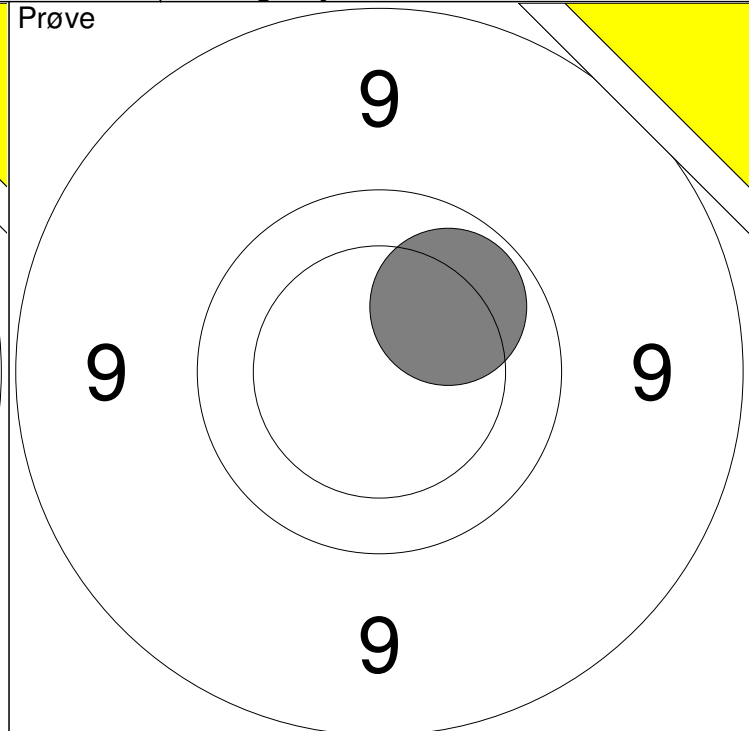
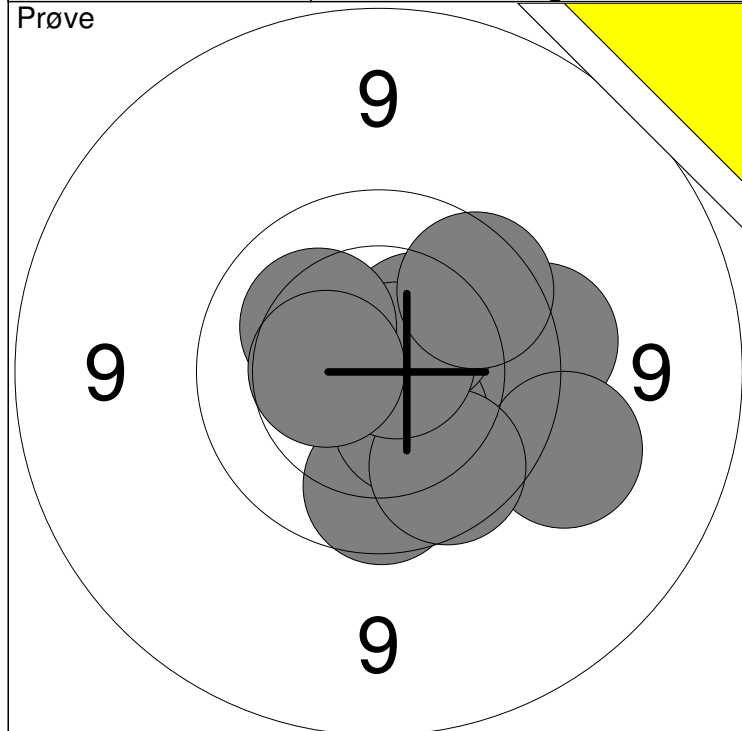

1: 9.6 →	6: 9.9 ↓	Serie	95.0
2: 9.4 →	7: *10.7 ↗		
3: 9.9 ↓	8: 10.2 ↖	Total	0.0
4: 10.4 ↓	9: 10.4 ←		
5: 10.4 ↗	10: 9.8 ↗		

11: 10.0 ↗		Serie	10.0
		Total	0.0

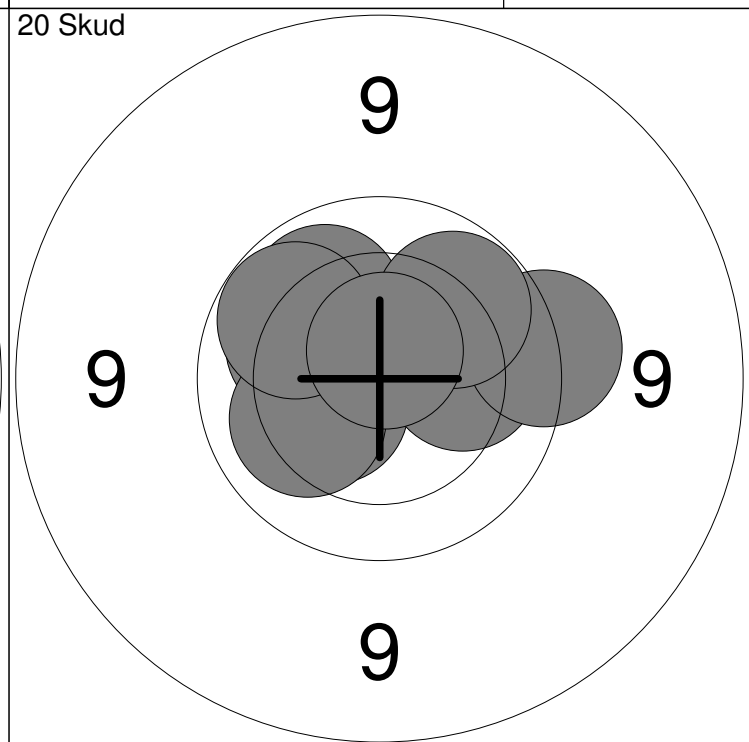
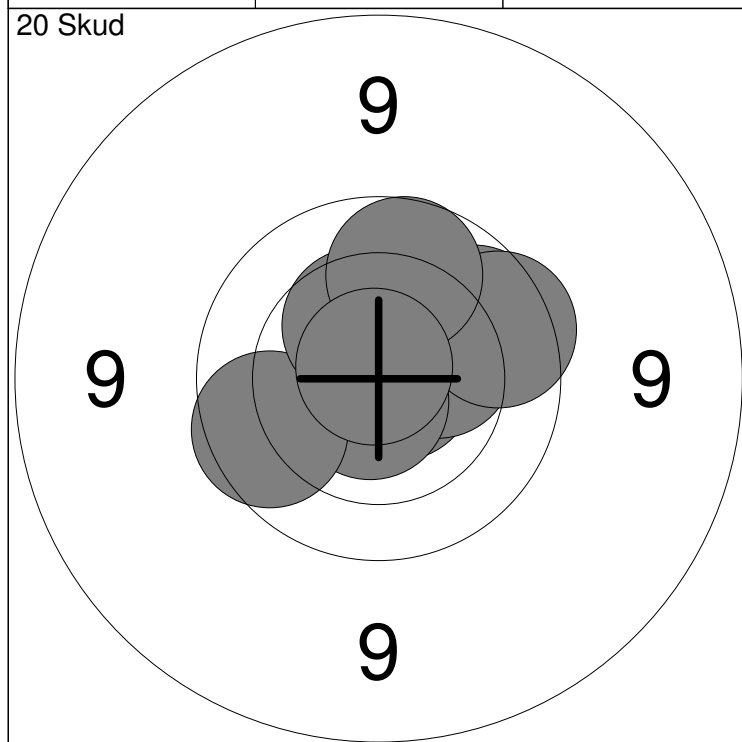

1: *10.8 →	6: *10.7 ↓	Serie	96.0
2: 9.9 ↗	7: 9.9 ←		
3: *10.7 ↗	8: 10.4 ↑	Total	96.0
4: 10.4 →	9: 9.9 ↑		
5: 9.8 →	10: *10.8 ↗		

11: 10.4 ←	16: 10.2 ←	Serie	99.0
12: 10.1 →	17: 10.0 ↖		
13: 9.6 →	18: 10.0 ↗	Total	195.0
14: 10.2 ↖	19: 10.0 ↖		
15: 10.4 ↖	20: *10.7 ↑		

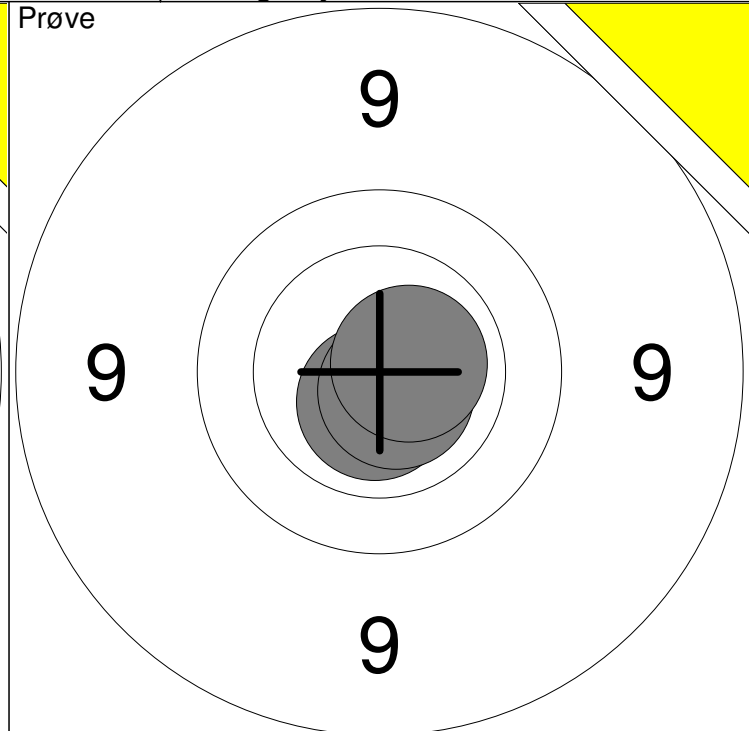
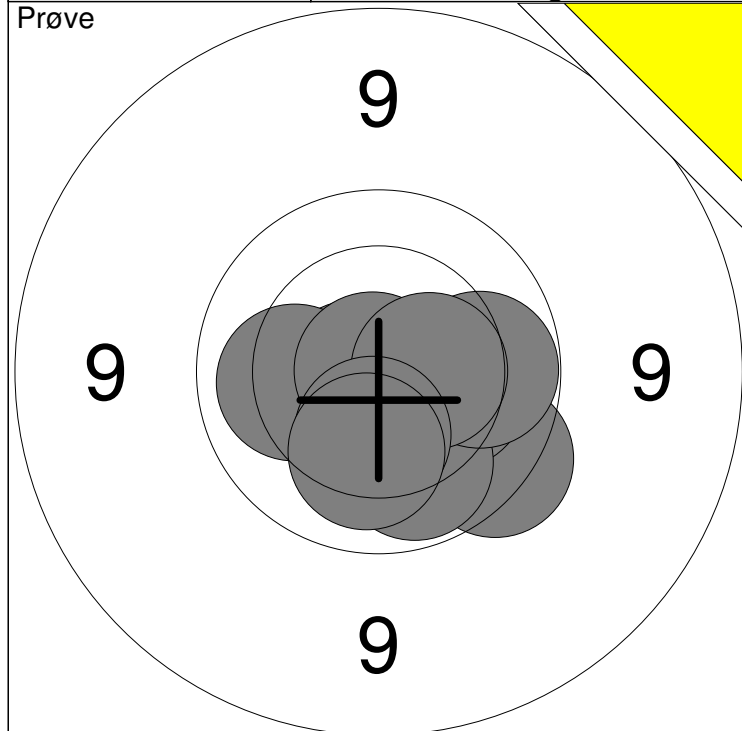

1: *10.7←	6: 10.0 ↓	Serie	99.0
2: 10.1 ←	7: 10.0 →		
3: *10.9←	8: 10.5 →	Total	0.0
4: 9.7 ↘	9: 10.3 ↓		
5: 10.2 →	10: 10.2 ↓		

11: *10.7↓	Serie	30.0
12: *10.7↘		
13: *10.7→	Total	0.0

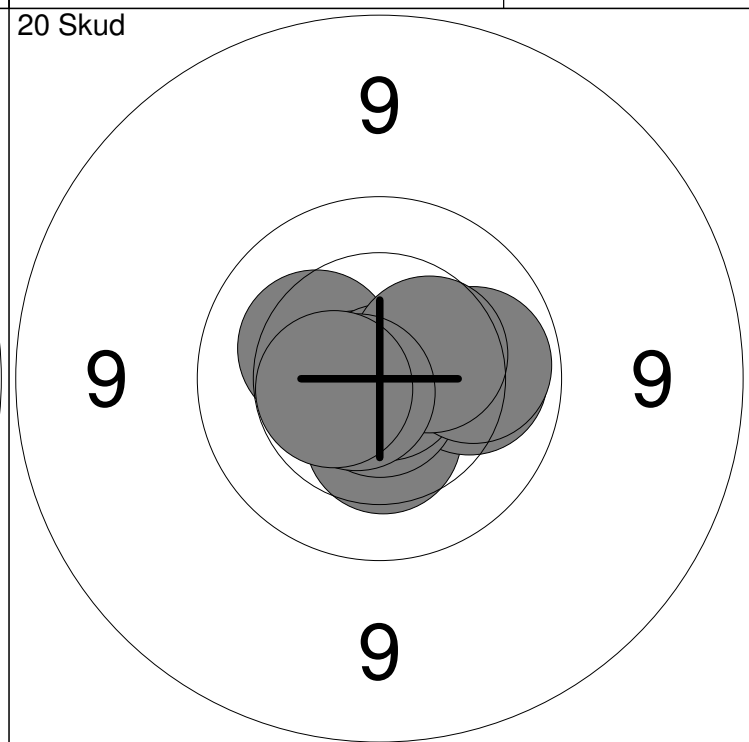
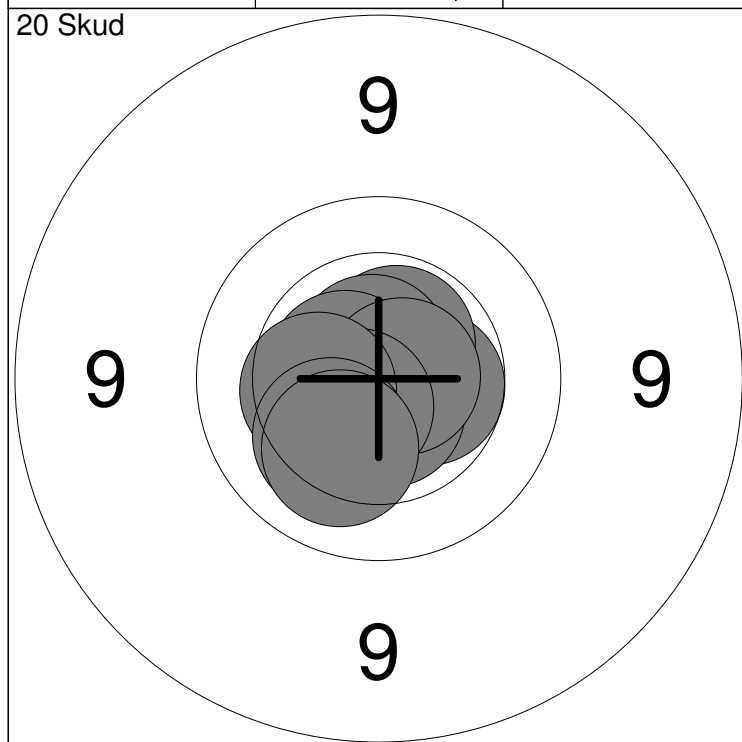

1: 10.5 →	6: *10.7→	Serie	100.0
2: *10.6↗	7: *10.6↘		
3: *10.7↗	8: 10.4 ←	Total	100.0
4: *10.6↓	9: 10.2 ↘		
5: *10.6↖	10: 10.2 ↘		

11: 10.4 ↓	16: *10.9↘	Serie	100.0
12: 10.1 →	17: 10.0 →		
13: 10.3 ↖	18: 10.4 ↗	Total	200.0
14: *10.8↓	19: *10.7↖		
15: *10.7↖	20: *10.5↖		

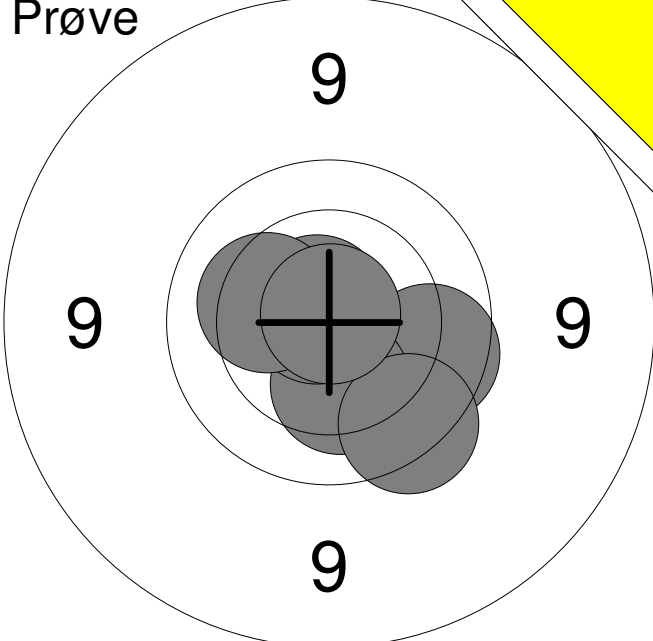
<p>Prøve</p> 	<table style="width:100%; border-collapse: collapse;"> <tr><td style="width:10%;">1:</td><td style="width:70%;">9.9</td><td style="width:20%; text-align: right;">→</td></tr> <tr><td>2:</td><td>10.3</td><td style="text-align: right;">↓</td></tr> <tr><td>3:</td><td>9.7</td><td style="text-align: right;">↘</td></tr> <tr><td>4:</td><td>*10.8</td><td style="text-align: right;">↗</td></tr> <tr><td>5:</td><td>*10.7</td><td style="text-align: right;">↗</td></tr> <tr><td>6:</td><td>10.2</td><td style="text-align: right;">↖</td></tr> <tr><td>7:</td><td>*10.9</td><td style="text-align: right;">↑</td></tr> </table>	1:	9.9	→	2:	10.3	↓	3:	9.7	↘	4:	*10.8	↗	5:	*10.7	↗	6:	10.2	↖	7:	*10.9	↑
1:	9.9	→																				
2:	10.3	↓																				
3:	9.7	↘																				
4:	*10.8	↗																				
5:	*10.7	↗																				
6:	10.2	↖																				
7:	*10.9	↑																				
		Serie 68.0																				
		Total 0.0																				

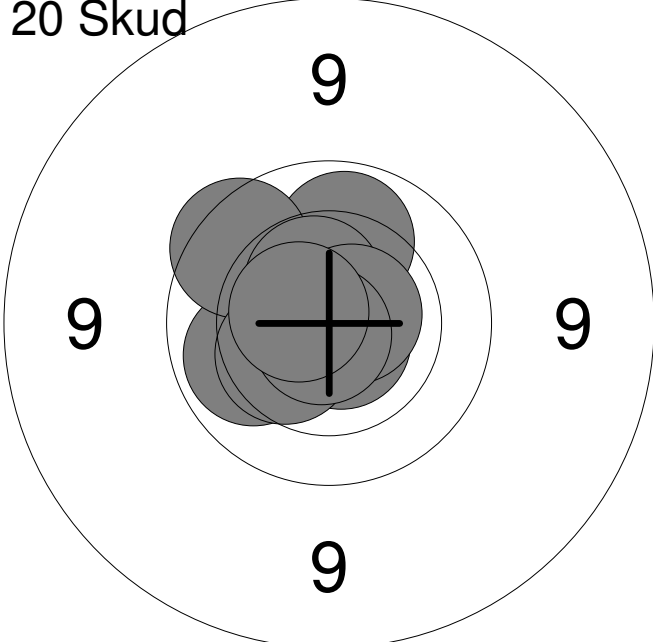
<p>20 Skud</p> 	<table style="width:100%; border-collapse: collapse;"> <tr><td style="width:10%;">1:</td><td style="width:70%;">10.1</td><td style="width:20%; text-align: right;">↙</td></tr> <tr><td>2:</td><td>10.1</td><td style="text-align: right;">↑</td></tr> <tr><td>3:</td><td>9.8</td><td style="text-align: right;">↘</td></tr> <tr><td>4:</td><td>*10.7</td><td style="text-align: right;">↙</td></tr> <tr><td>5:</td><td>*10.7</td><td style="text-align: right;">↓</td></tr> <tr><td>6:</td><td>10.4</td><td style="text-align: right;">↙</td></tr> <tr><td>7:</td><td>*10.5</td><td style="text-align: right;">↑</td></tr> <tr><td>8:</td><td>*10.7</td><td style="text-align: right;">→</td></tr> <tr><td>9:</td><td>*10.8</td><td style="text-align: right;">↘</td></tr> <tr><td>10:</td><td>*10.6</td><td style="text-align: right;">↙</td></tr> </table>	1:	10.1	↙	2:	10.1	↑	3:	9.8	↘	4:	*10.7	↙	5:	*10.7	↓	6:	10.4	↙	7:	*10.5	↑	8:	*10.7	→	9:	*10.8	↘	10:	*10.6	↙
1:	10.1	↙																													
2:	10.1	↑																													
3:	9.8	↘																													
4:	*10.7	↙																													
5:	*10.7	↓																													
6:	10.4	↙																													
7:	*10.5	↑																													
8:	*10.7	→																													
9:	*10.8	↘																													
10:	*10.6	↙																													
		Serie 99.0																													
		Total 99.0																													

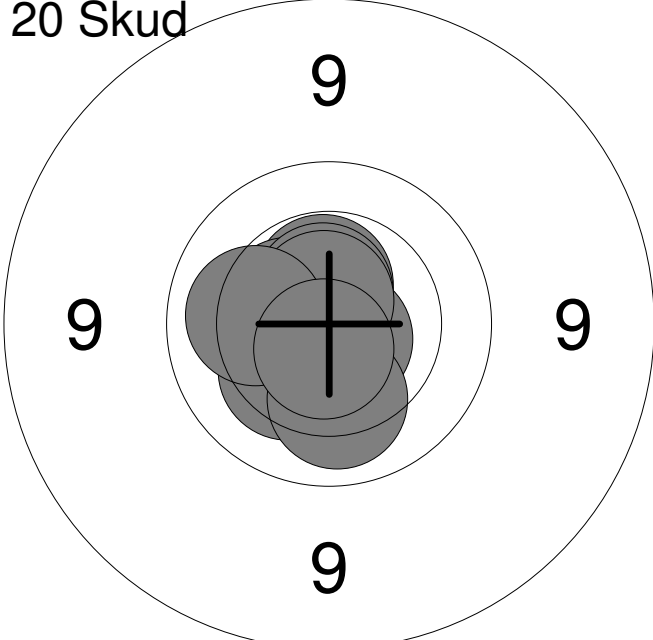
<p>20 Skud</p> 	<table style="width:100%; border-collapse: collapse;"> <tr><td style="width:10%;">11:</td><td style="width:70%;">10.3</td><td style="width:20%; text-align: right;">↘</td></tr> <tr><td>12:</td><td>*10.5</td><td style="text-align: right;">↑</td></tr> <tr><td>13:</td><td>10.5</td><td style="text-align: right;">↖</td></tr> <tr><td>14:</td><td>*10.7</td><td style="text-align: right;">↘</td></tr> <tr><td>15:</td><td>*10.6</td><td style="text-align: right;">↑</td></tr> <tr><td>16:</td><td>*10.8</td><td style="text-align: right;">↖</td></tr> <tr><td>17:</td><td>*10.7</td><td style="text-align: right;">↑</td></tr> <tr><td>18:</td><td>10.2</td><td style="text-align: right;">↖</td></tr> <tr><td>19:</td><td>10.1</td><td style="text-align: right;">↓</td></tr> <tr><td>20:</td><td>*10.7</td><td style="text-align: right;">↓</td></tr> </table>	11:	10.3	↘	12:	*10.5	↑	13:	10.5	↖	14:	*10.7	↘	15:	*10.6	↑	16:	*10.8	↖	17:	*10.7	↑	18:	10.2	↖	19:	10.1	↓	20:	*10.7	↓
11:	10.3	↘																													
12:	*10.5	↑																													
13:	10.5	↖																													
14:	*10.7	↘																													
15:	*10.6	↑																													
16:	*10.8	↖																													
17:	*10.7	↑																													
18:	10.2	↖																													
19:	10.1	↓																													
20:	*10.7	↓																													
		Serie 100.0																													
		Total 199.0																													

<p>Prøve</p> 	<table style="width:100%; border-collapse: collapse;"> <tr><td>1:</td><td>9.2</td><td>↙</td></tr> <tr><td>2:</td><td>9.4</td><td>←</td></tr> <tr><td>3:</td><td>9.4</td><td>↗</td></tr> <tr><td>4:</td><td>10.4</td><td>↗</td></tr> <tr><td>5:</td><td>9.2</td><td>↑</td></tr> <tr><td>6:</td><td>*10.7</td><td>↗</td></tr> <tr><td>7:</td><td>10.3</td><td>↙</td></tr> <tr><td>8:</td><td>10.4</td><td>↗</td></tr> </table>	1:	9.2	↙	2:	9.4	←	3:	9.4	↗	4:	10.4	↗	5:	9.2	↑	6:	*10.7	↗	7:	10.3	↙	8:	10.4	↗
1:	9.2	↙																							
2:	9.4	←																							
3:	9.4	↗																							
4:	10.4	↗																							
5:	9.2	↑																							
6:	*10.7	↗																							
7:	10.3	↙																							
8:	10.4	↗																							
	Serie 76.0																								
	Total 0.0																								

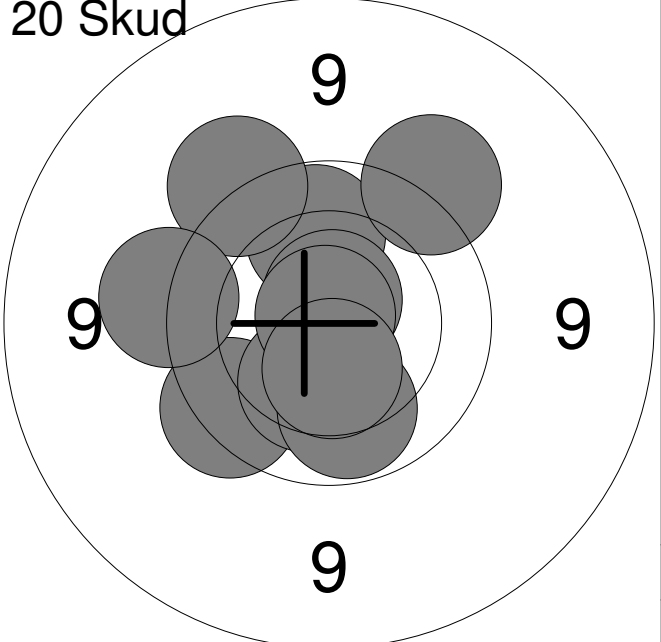
<p>20 Skud</p> 	<table style="width:100%; border-collapse: collapse;"> <tr><td>1:</td><td>9.7</td><td>↙</td></tr> <tr><td>2:</td><td>10.3</td><td>↓</td></tr> <tr><td>3:</td><td>10.0</td><td>↓</td></tr> <tr><td>4:</td><td>10.0</td><td>↑</td></tr> <tr><td>5:</td><td>9.5</td><td>↗</td></tr> <tr><td>6:</td><td>*10.7</td><td>↑</td></tr> <tr><td>7:</td><td>9.5</td><td>←</td></tr> <tr><td>8:</td><td>*10.9</td><td>↗</td></tr> <tr><td>9:</td><td>9.5</td><td>↗</td></tr> <tr><td>10:</td><td>10.5</td><td>↓</td></tr> </table>	1:	9.7	↙	2:	10.3	↓	3:	10.0	↓	4:	10.0	↑	5:	9.5	↗	6:	*10.7	↑	7:	9.5	←	8:	*10.9	↗	9:	9.5	↗	10:	10.5	↓
1:	9.7	↙																													
2:	10.3	↓																													
3:	10.0	↓																													
4:	10.0	↑																													
5:	9.5	↗																													
6:	*10.7	↑																													
7:	9.5	←																													
8:	*10.9	↗																													
9:	9.5	↗																													
10:	10.5	↓																													
	Serie 96.0																														
	Total 96.0																														

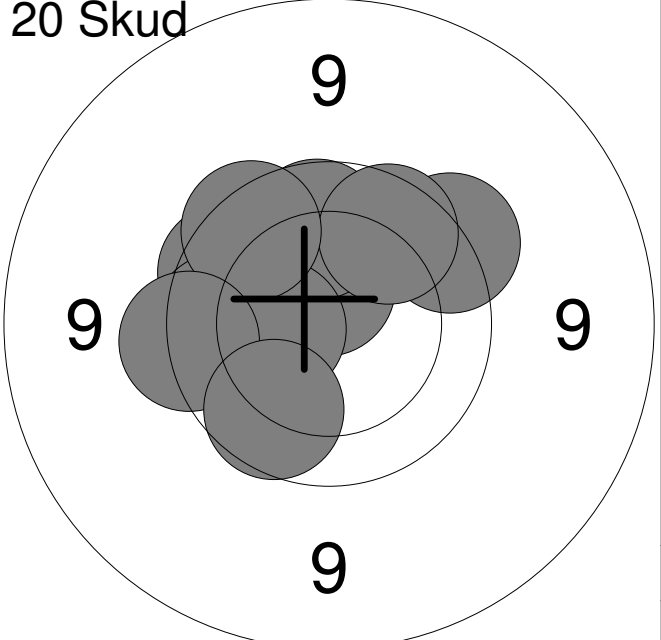
<p>20 Skud</p> 	<table style="width:100%; border-collapse: collapse;"> <tr><td>11:</td><td>9.6</td><td>↗</td></tr> <tr><td>12:</td><td>9.8</td><td>↙</td></tr> <tr><td>13:</td><td>*10.5</td><td>↑</td></tr> <tr><td>14:</td><td>9.9</td><td>←</td></tr> <tr><td>15:</td><td>9.9</td><td>↑</td></tr> <tr><td>16:</td><td>10.4</td><td>←</td></tr> <tr><td>17:</td><td>9.9</td><td>↗</td></tr> <tr><td>18:</td><td>9.8</td><td>↗</td></tr> <tr><td>19:</td><td>9.7</td><td>←</td></tr> <tr><td>20:</td><td>9.9</td><td>↙</td></tr> </table>	11:	9.6	↗	12:	9.8	↙	13:	*10.5	↑	14:	9.9	←	15:	9.9	↑	16:	10.4	←	17:	9.9	↗	18:	9.8	↗	19:	9.7	←	20:	9.9	↙
11:	9.6	↗																													
12:	9.8	↙																													
13:	*10.5	↑																													
14:	9.9	←																													
15:	9.9	↑																													
16:	10.4	←																													
17:	9.9	↗																													
18:	9.8	↗																													
19:	9.7	←																													
20:	9.9	↙																													
	Serie 92.0																														
	Total 188.0																														

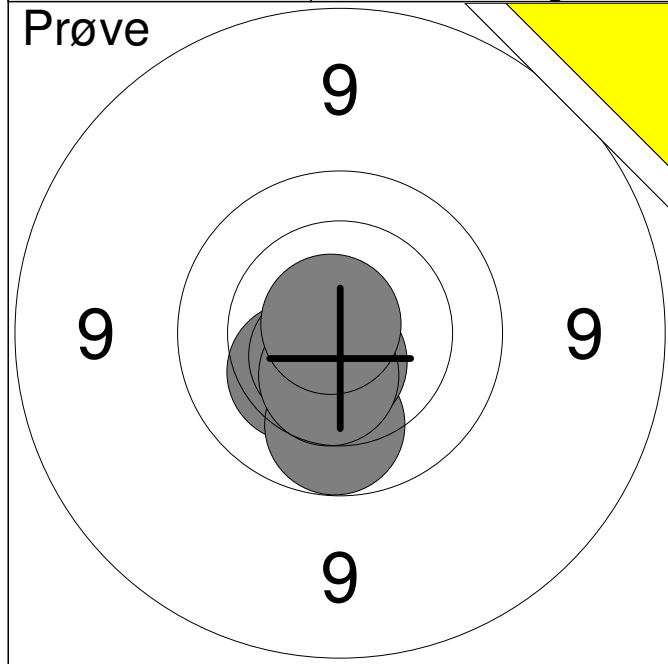

1:	10.3	↙
2:	10.0	↓
3:	*10.6	↙
4:	*10.6	↓
5:	10.5	↙
6:	*10.8	↗
Serie		60.0
Total		0.0

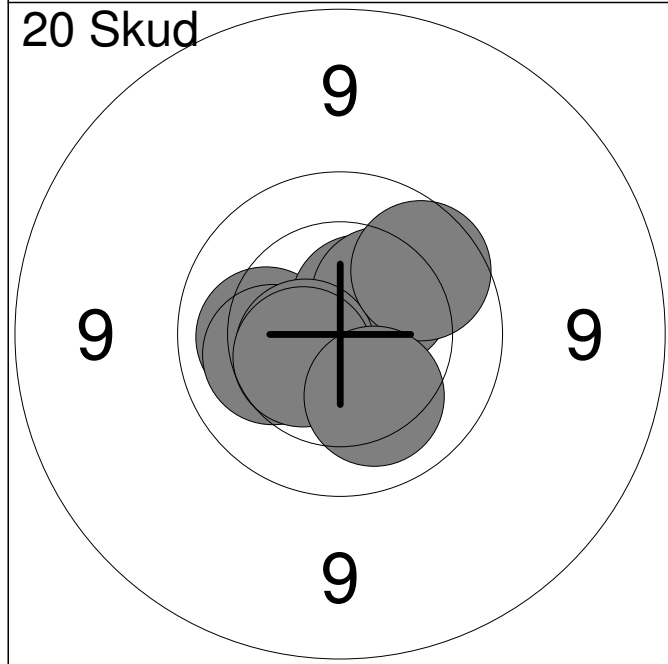

1:	10.3	←
2:	*10.7	↙
3:	10.1	←
4:	*10.6	↗
5:	10.3	↗
6:	10.2	←
7:	*10.5	←
8:	9.9	↗
9:	10.5	↙
10:	10.2	↓
Serie		99.0
Total		99.0

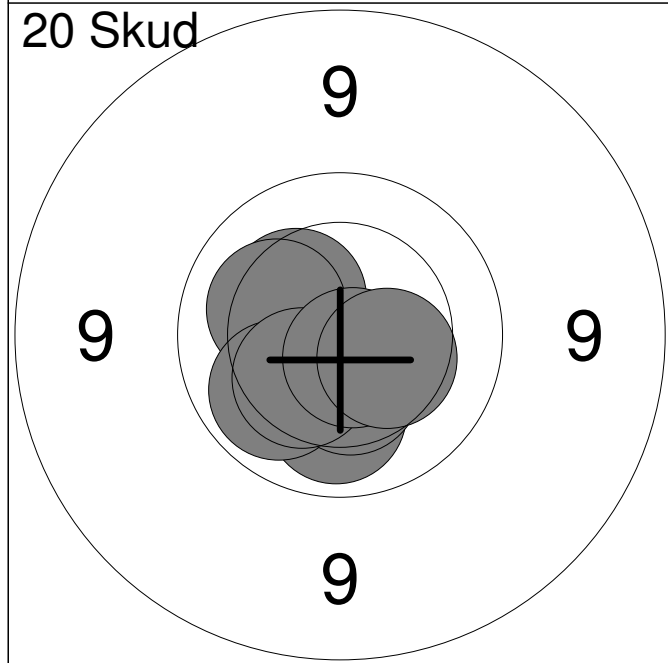

11:	10.4	←
12:	10.3	↙
13:	10.3	↗
14:	10.2	↗
15:	10.1	↓
16:	10.1	↙
17:	10.4	↓
18:	10.3	↙
19:	*10.7	↓
20:	10.4	↘
Serie		100.0
Total		199.0

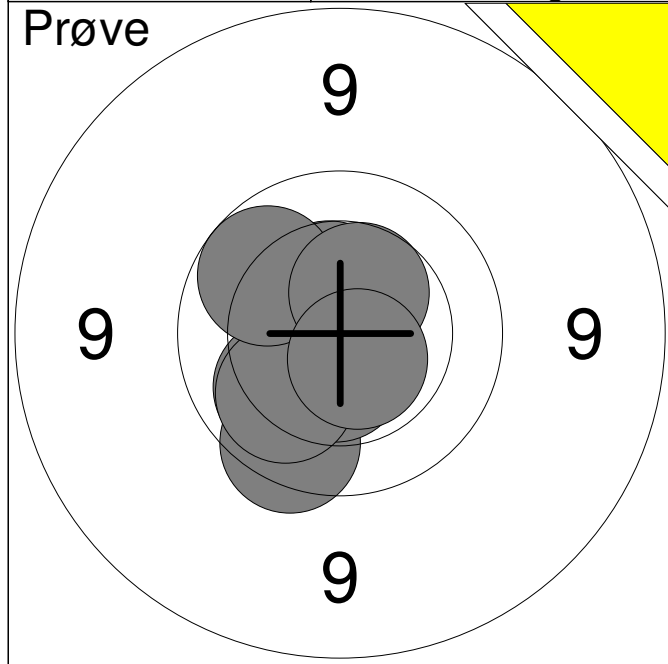

1:	9.8	↙
2:	10.5	↑
3:	*10.7	↘
4:	*10.5	↘
5:	10.1	↙
6:	10.1	↙
7:	9.9	↗
8:	10.5	↗
9:	*10.6	↘
Serie		88.0
Total		0.0

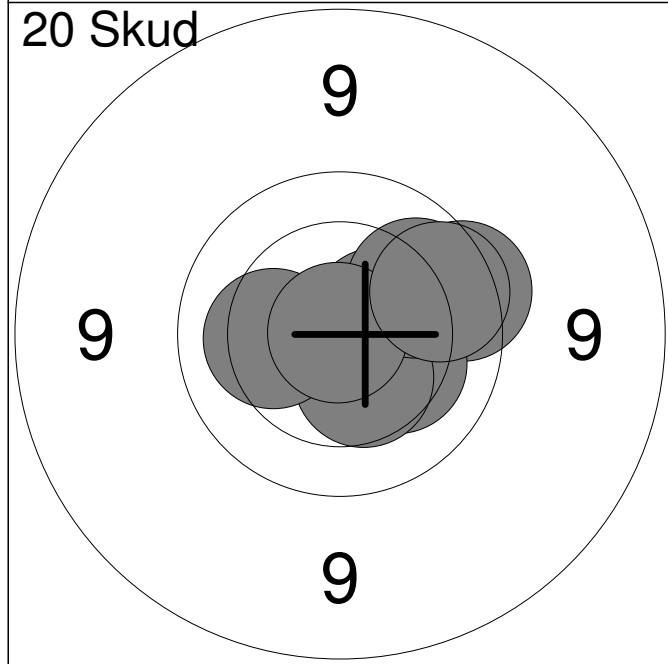

1:	10.5	→
2:	9.7	→
3:	10.2	→
4:	10.3	↘
5:	*10.7	↘
6:	10.4	↘
7:	10.2	←
8:	10.0	↗
9:	*10.9	↗
10:	9.8	→
Serie		98.0
Total		98.0

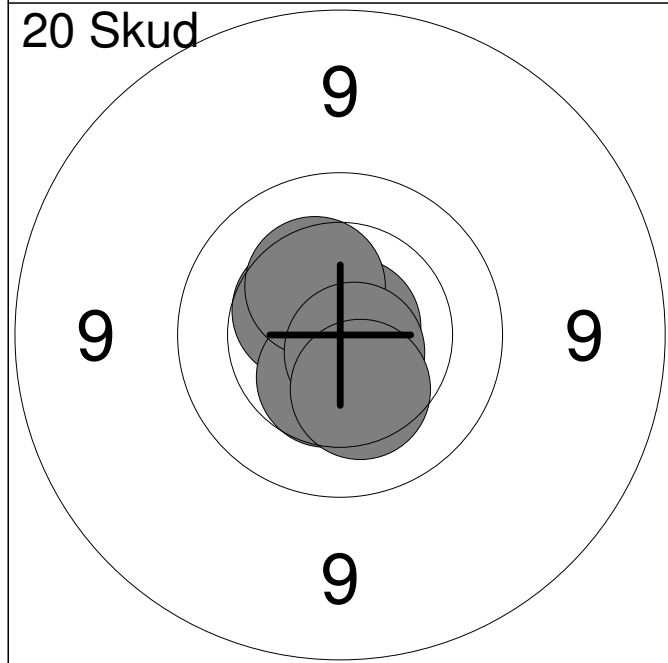

11:	*10.8	↗
12:	*10.8	↙
13:	*10.6	↗
14:	*10.7	↘
15:	*10.8	↘
16:	10.5	↗
17:	10.5	↘
18:	10.4	↗
19:	*10.7	↘
20:	10.3	↘
Serie		100.0
Total		198.0

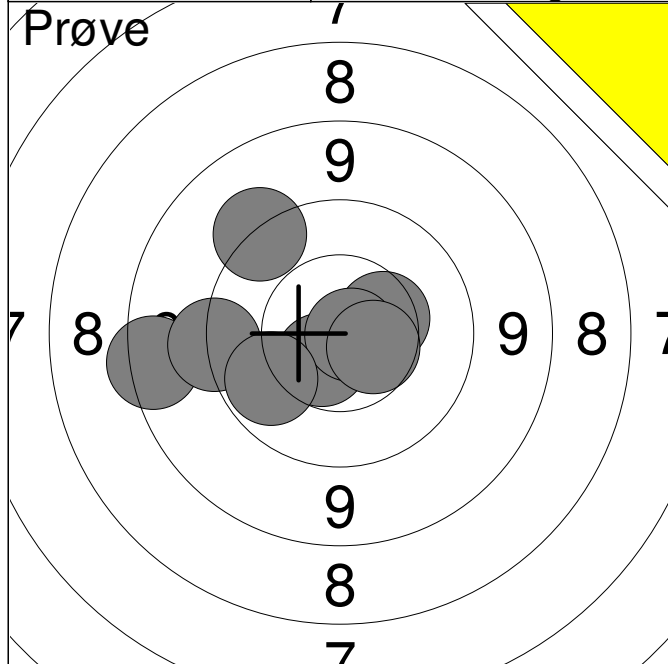

1:	8.6	←
2:	9.4	←
3:	10.6	↙
4:	9.4	↗
5:	10.4	→
6:	*10.8	→
7:	10.0	↙
8:	10.5	↘
Serie		76.0
Total		0.0

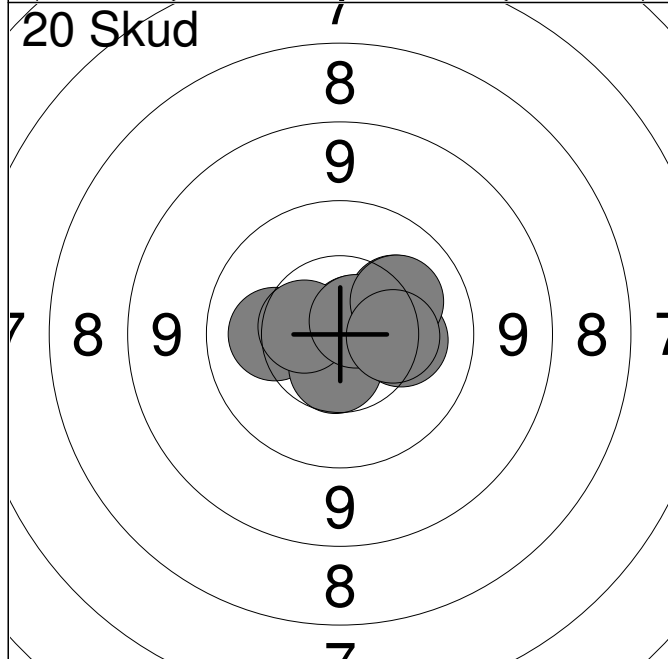

1:	*10.7	↗
2:	*10.7	→
3:	10.2	↗
4:	10.2	←
5:	10.6	↓
6:	10.5	←
7:	*10.7	↗
8:	10.2	→
9:	10.2	↗
10:	10.3	→
Serie		100.0
Total		100.0

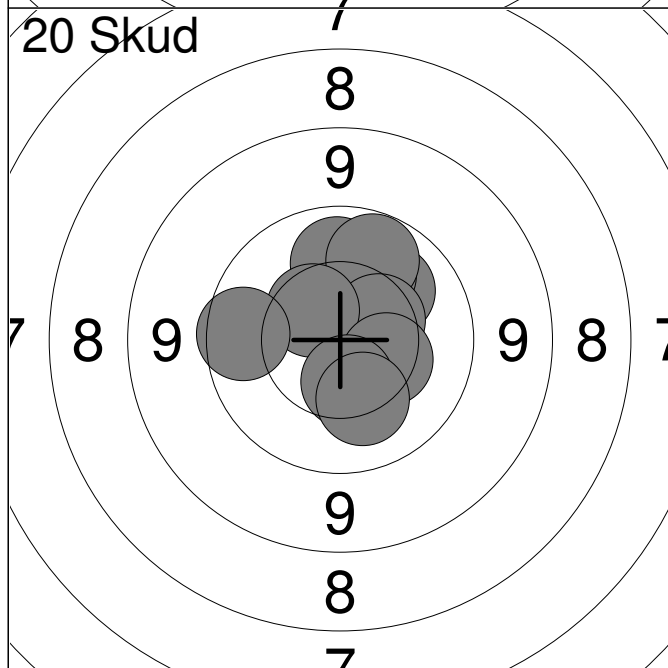

11:	10.2	↗
12:	10.1	↗
13:	10.1	↑
14:	10.0	↗
15:	10.4	↗
16:	10.5	↗
17:	9.8	←
18:	10.4	↘
19:	10.5	↓
20:	10.2	↓
Serie		99.0
Total		199.0

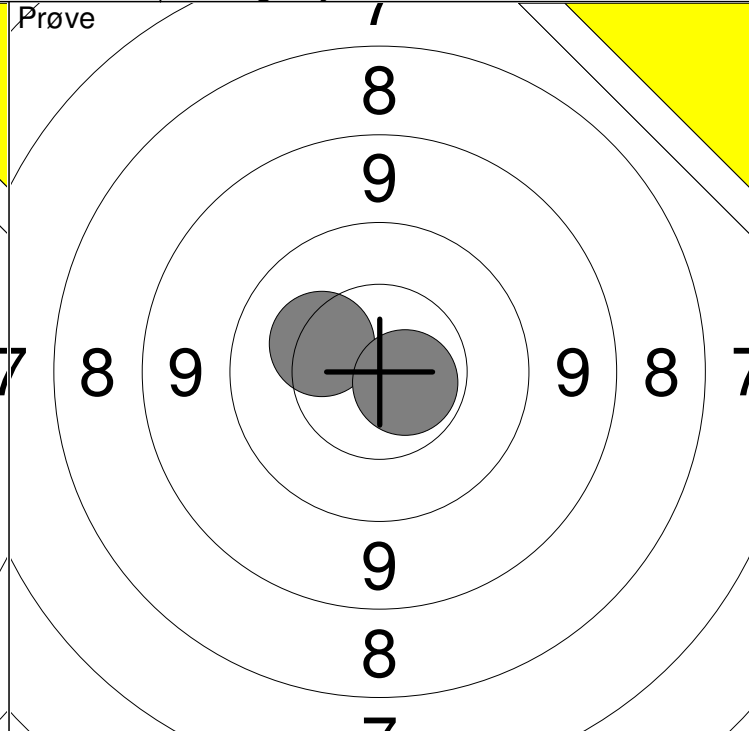
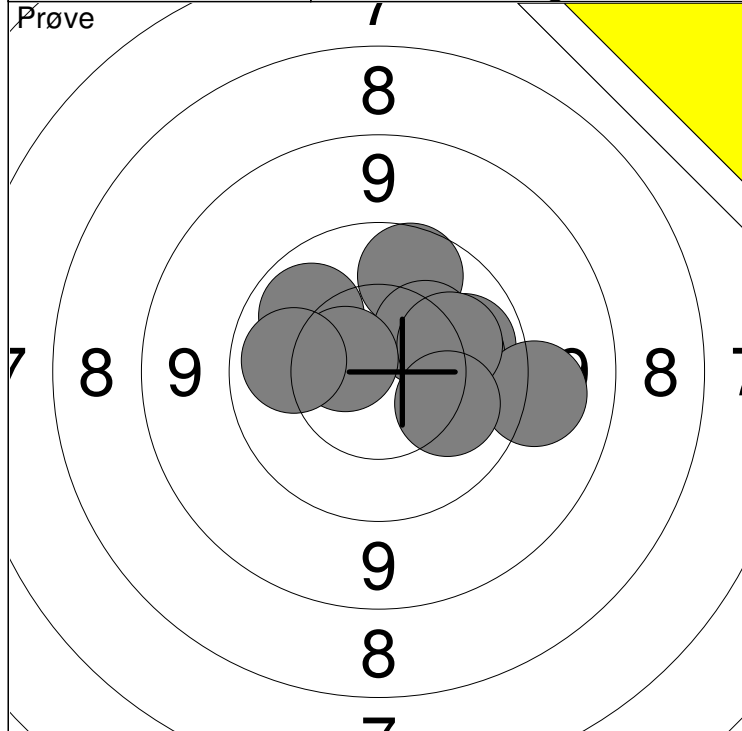

1: 10.0 →	6: 10.0 ↖	Serie	98.0
2: 10.2 →	7: 10.2 →		
3: 9.3 →	8: 10.2 →	Total	0.0
4: 9.9 ↑	9: 10.6 ↖		
5: 10.3 ↗	10: 10.1 ←		

11: 10.3 ↖	Serie	20.0
12: *10.7 →		
	Total	0.0

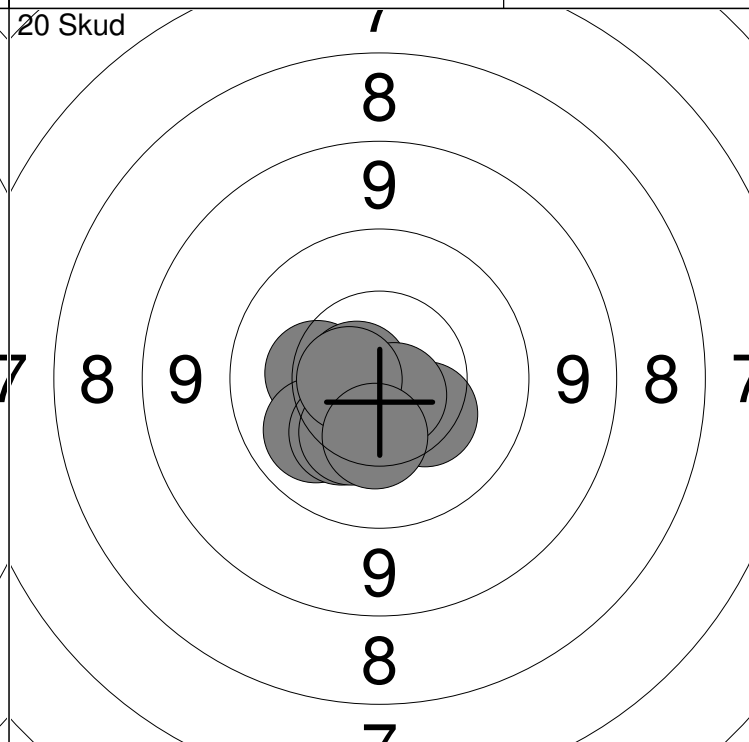
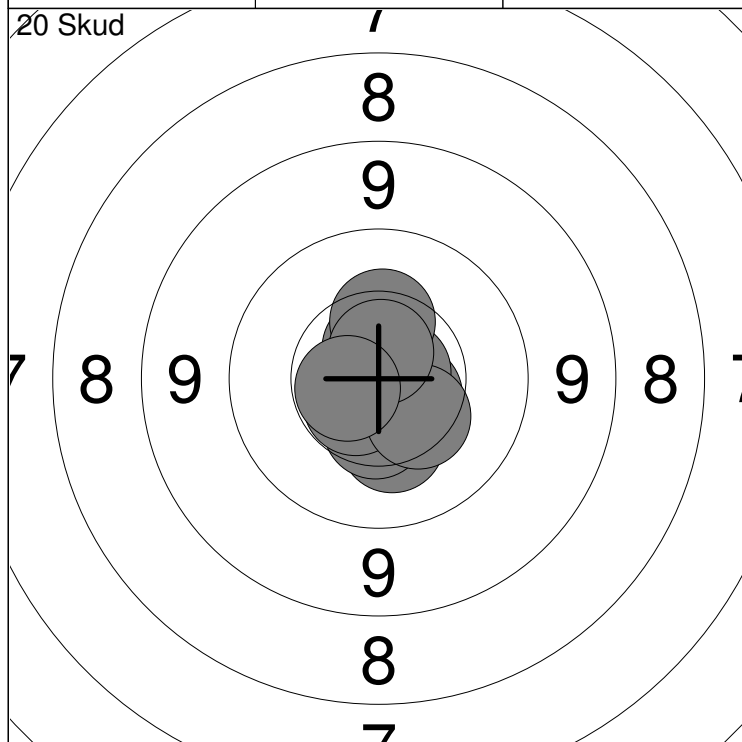

1: 10.3 ↓	6: *10.7 →	Serie	100.0
2: 10.5 ↓	7: 10.4 ↑		
3: *10.6 ↑	8: 10.4 ↘	Total	100.0
4: 10.6 →	9: *10.7 ↑		
5: *10.6 ↙	10: *10.6 ↖		

11: 10.3 ↖	16: 10.3 ↙	Serie	100.0
12: *10.6 ↓	17: 10.3 ↓		
13: 10.1 ↖	18: *10.7 ↘	Total	200.0
14: 10.4 ↘	19: *10.6 ↖		
15: *10.7 ↖	20: 10.4 ↓		

Hold	Skive	Kaj Mørk	
4	5	15m	Vester Hassing Skf. J1
1/3 - 3/3 2013	NM 15 meter Ungdom 2013	Aalborg Skyttekreds	
Prøve 	1:	10.2	→
	2:	10.4	↓
	3:	9.6	↘
	4:	*10.7	↑
	5:	*10.8	↑
	6:	10.2	→
	7:	9.8	→
	8:	9.5	↗
	9:	10.2	↗
	10:	10.3	↑
	Serie		
Total			0.0
20 Skud 	1:	10.0	↑
	2:	*10.7	→
	3:	*10.7	←
	4:	10.3	↗
	5:	10.5	↓
	6:	*10.7	↑
	7:	10.6	↑
	8:	10.5	↑
	9:	10.3	↗
	10:	10.5	↑
	Serie		
Total			100.0
20 Skud 	11:	10.2	→
	12:	10.4	↗
	13:	*10.7	↓
	14:	10.6	↗
	15:	*10.6	↗
	16:	*10.6	↓
	17:	10.5	↗
	18:	10.5	↗
	19:	*10.7	↗
	20:	*10.6	↗
	Serie		
Total			200.0

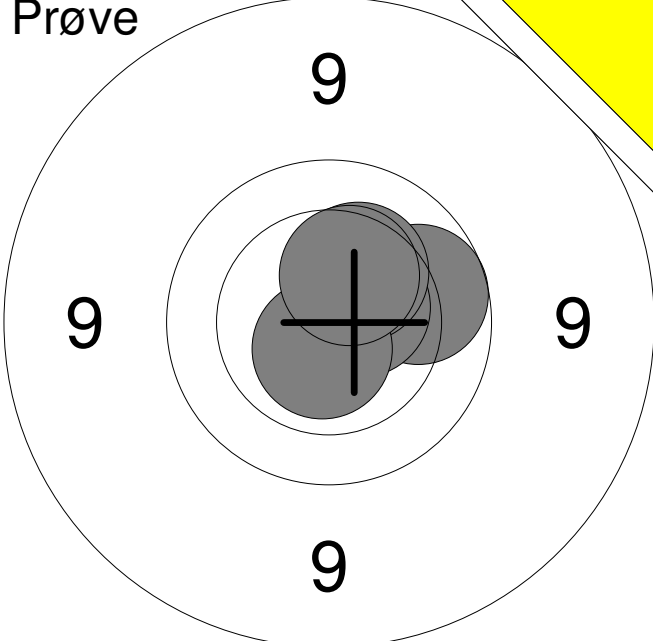
<p>Prøve</p> 	<table style="width:100%; border-collapse: collapse;"> <tr><td style="width:10%;">1:</td><td style="width:15%;">9.9</td><td style="width:10%; text-align: right;">→</td></tr> <tr><td>2:</td><td>*10.6</td><td style="text-align: right;">↗</td></tr> <tr><td>3:</td><td>10.3</td><td style="text-align: right;">↗</td></tr> <tr><td>4:</td><td>*10.7</td><td style="text-align: right;">↓</td></tr> <tr><td>5:</td><td>10.4</td><td style="text-align: right;">↗</td></tr> <tr><td colspan="3"><hr/></td></tr> <tr><td colspan="2">Serie</td><td style="text-align: right;">49.0</td></tr> <tr><td colspan="2">Total</td><td style="text-align: right;">0.0</td></tr> </table>	1:	9.9	→	2:	*10.6	↗	3:	10.3	↗	4:	*10.7	↓	5:	10.4	↗	<hr/>			Serie		49.0	Total		0.0
1:	9.9	→																							
2:	*10.6	↗																							
3:	10.3	↗																							
4:	*10.7	↓																							
5:	10.4	↗																							
<hr/>																									
Serie		49.0																							
Total		0.0																							

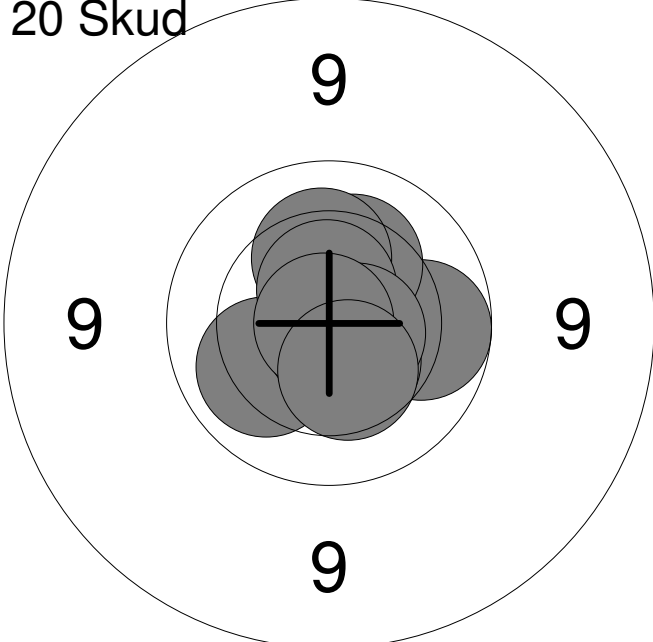
<p>20 Skud</p> 	<table style="width:100%; border-collapse: collapse;"> <tr><td style="width:10%;">1:</td><td style="width:15%;">9.9</td><td style="width:10%; text-align: right;">→</td></tr> <tr><td>2:</td><td>10.5</td><td style="text-align: right;">↓</td></tr> <tr><td>3:</td><td>10.1</td><td style="text-align: right;">↙</td></tr> <tr><td>4:</td><td>10.3</td><td style="text-align: right;">↗</td></tr> <tr><td>5:</td><td>*10.8</td><td style="text-align: right;">↓</td></tr> <tr><td>6:</td><td>10.2</td><td style="text-align: right;">↑</td></tr> <tr><td>7:</td><td>*10.6</td><td style="text-align: right;">↑</td></tr> <tr><td>8:</td><td>*10.6</td><td style="text-align: right;">→</td></tr> <tr><td>9:</td><td>*10.9</td><td style="text-align: right;">←</td></tr> <tr><td>10:</td><td>10.4</td><td style="text-align: right;">↓</td></tr> <tr><td colspan="3"><hr/></td></tr> <tr><td colspan="2">Serie</td><td style="text-align: right;">99.0</td></tr> <tr><td colspan="2">Total</td><td style="text-align: right;">99.0</td></tr> </table>	1:	9.9	→	2:	10.5	↓	3:	10.1	↙	4:	10.3	↗	5:	*10.8	↓	6:	10.2	↑	7:	*10.6	↑	8:	*10.6	→	9:	*10.9	←	10:	10.4	↓	<hr/>			Serie		99.0	Total		99.0
1:	9.9	→																																						
2:	10.5	↓																																						
3:	10.1	↙																																						
4:	10.3	↗																																						
5:	*10.8	↓																																						
6:	10.2	↑																																						
7:	*10.6	↑																																						
8:	*10.6	→																																						
9:	*10.9	←																																						
10:	10.4	↓																																						
<hr/>																																								
Serie		99.0																																						
Total		99.0																																						

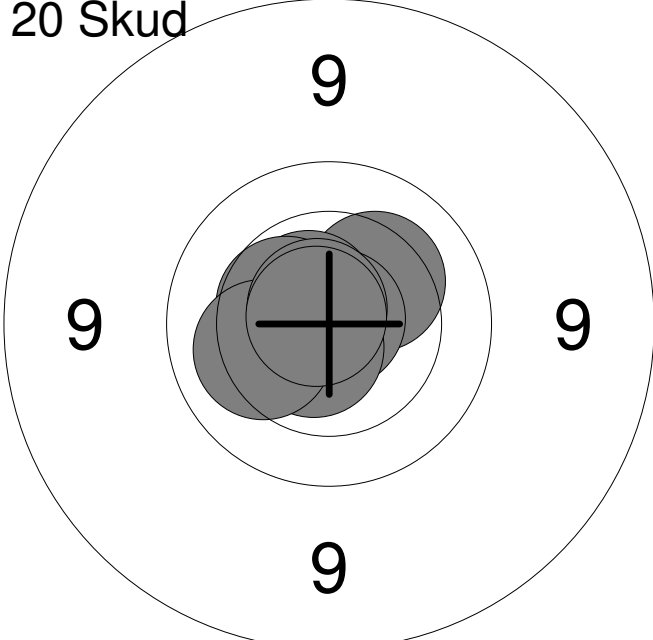
<p>20 Skud</p> 	<table style="width:100%; border-collapse: collapse;"> <tr><td style="width:10%;">11:</td><td style="width:15%;">10.3</td><td style="width:10%; text-align: right;">↗</td></tr> <tr><td>12:</td><td>*10.8</td><td style="text-align: right;">↙</td></tr> <tr><td>13:</td><td>*10.6</td><td style="text-align: right;">←</td></tr> <tr><td>14:</td><td>*10.9</td><td style="text-align: right;">↗</td></tr> <tr><td>15:</td><td>*10.6</td><td style="text-align: right;">↗</td></tr> <tr><td>16:</td><td>10.4</td><td style="text-align: right;">↙</td></tr> <tr><td>17:</td><td>*10.6</td><td style="text-align: right;">↙</td></tr> <tr><td>18:</td><td>10.2</td><td style="text-align: right;">←</td></tr> <tr><td>19:</td><td>*10.7</td><td style="text-align: right;">↗</td></tr> <tr><td>20:</td><td>*10.8</td><td style="text-align: right;">↗</td></tr> <tr><td colspan="3"><hr/></td></tr> <tr><td colspan="2">Serie</td><td style="text-align: right;">100.0</td></tr> <tr><td colspan="2">Total</td><td style="text-align: right;">199.0</td></tr> </table>	11:	10.3	↗	12:	*10.8	↙	13:	*10.6	←	14:	*10.9	↗	15:	*10.6	↗	16:	10.4	↙	17:	*10.6	↙	18:	10.2	←	19:	*10.7	↗	20:	*10.8	↗	<hr/>			Serie		100.0	Total		199.0
11:	10.3	↗																																						
12:	*10.8	↙																																						
13:	*10.6	←																																						
14:	*10.9	↗																																						
15:	*10.6	↗																																						
16:	10.4	↙																																						
17:	*10.6	↙																																						
18:	10.2	←																																						
19:	*10.7	↗																																						
20:	*10.8	↗																																						
<hr/>																																								
Serie		100.0																																						
Total		199.0																																						

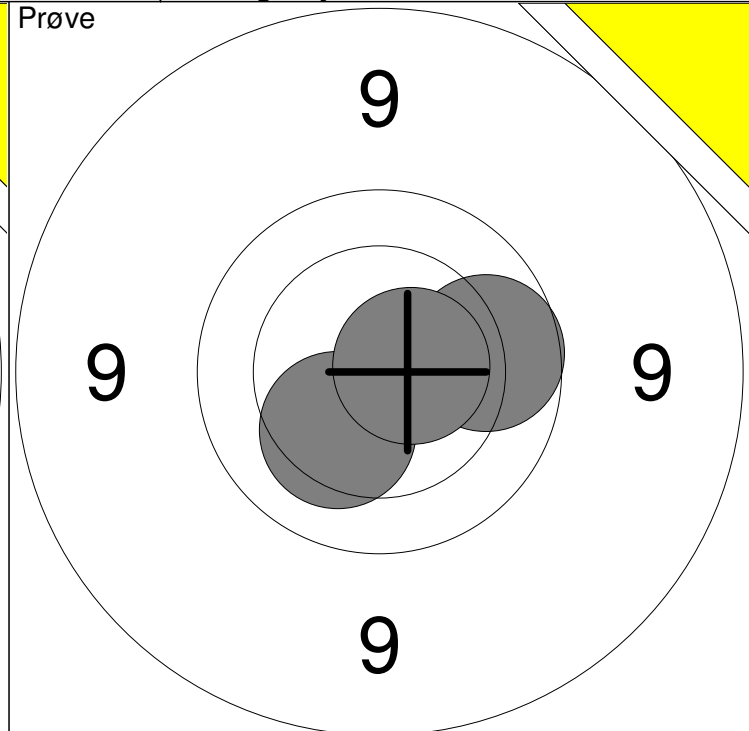
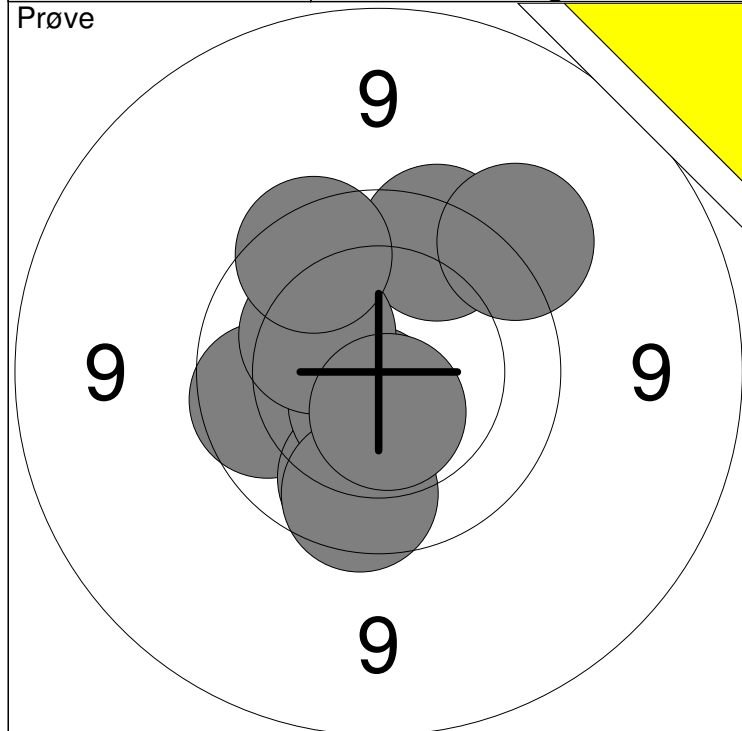

1: 9.7 ↗	6: *10.6 ↓	Serie	94.0
2: 9.5 ↗	7: 9.8 ↓		
3: 9.9 ←	8: 10.3 ↖	Total	0.0
4: 9.9 ↓	9: *10.6 ↓		
5: *10.6 ↓	10: 9.8 ↗		

11: 10.3 ↓	Serie	29.0
12: 9.9 →		
13: *10.6 →	Total	0.0

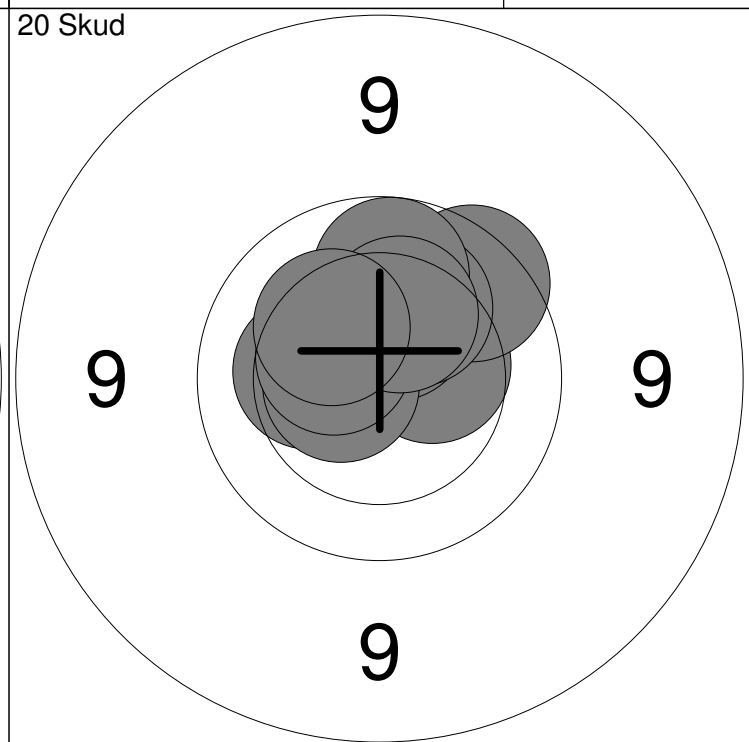
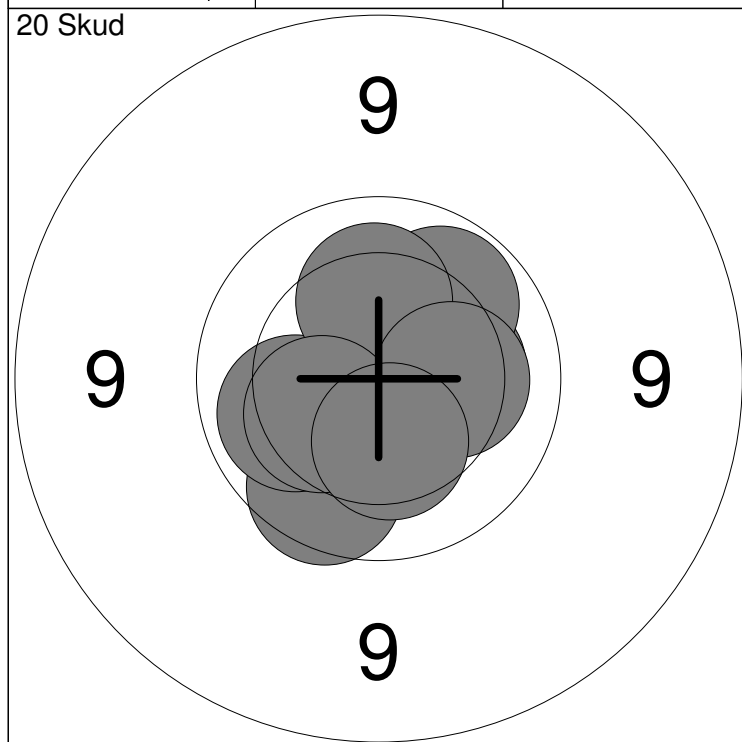

1: 10.3 →	6: 10.1 ←	Serie	99.0
2: 9.9 ↓	7: 10.2 ↑		
3: *10.7 →	8: 10.2 →	Total	99.0
4: *10.7 ↓	9: 10.3 ←		
5: 10.0 ↗	10: 10.3 ↓		

11: 10.4 →	16: *10.6 ←	Serie	98.0
12: 9.8 ↗	17: 9.9 ↑		
13: 10.3 ←	18: 10.5 ←	Total	197.0
14: 10.4 ↑	19: 10.3 ↑		
15: 10.2 ↗	20: 10.3 ↖		

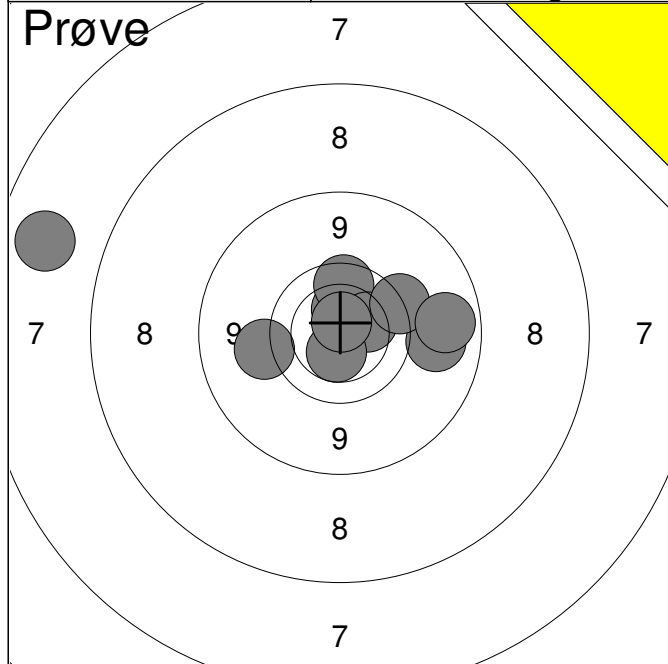

1:	9.2	→
2:	9.4	←
3:	10.4	↑
4:	9.8	↑
5:	10.2	→
6:	10.5	↓
7:	7.1	←
8:	9.6	→
9:	9.0	→
10:	*10.7	↑
Serie		92.0
Total		0.0

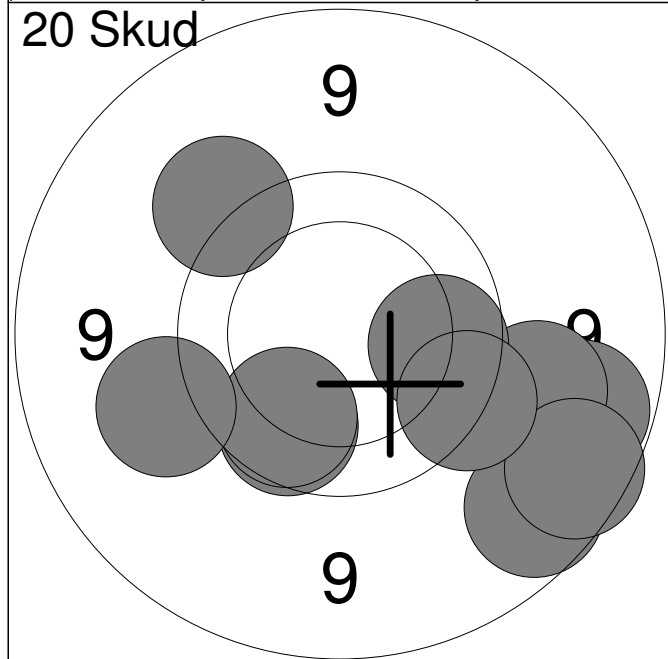

1:	8.9	↓
2:	9.0	→
3:	9.3	→
4:	8.9	↓
5:	9.5	↗
6:	9.9	↓
7:	9.9	→
8:	9.6	→
9:	9.9	↓
10:	9.4	←
Serie		88.0
Total		88.0

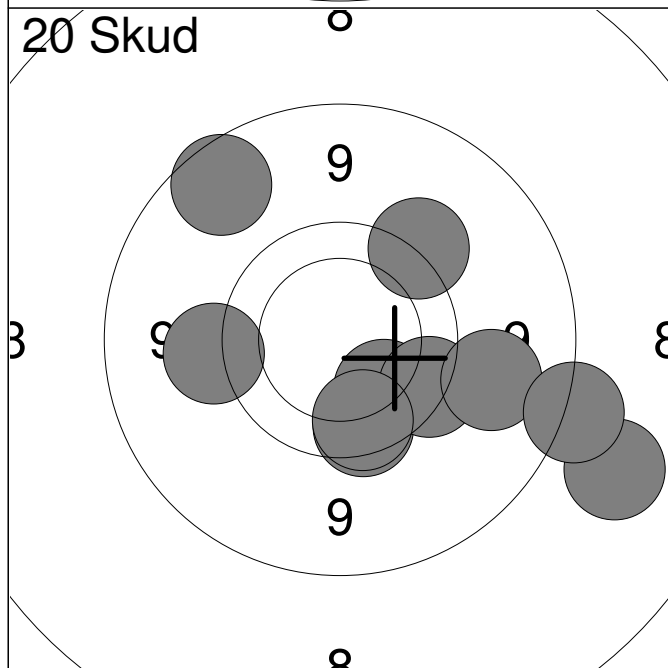

11:	9.8	↓
12:	9.4	←
13:	10.0	↓
14:	9.5	↗
15:	8.9	↗
16:	9.7	↓
17:	8.3	→
18:	9.2	→
19:	9.8	↓
20:	8.6	→
Serie		88.0
Total		176.0

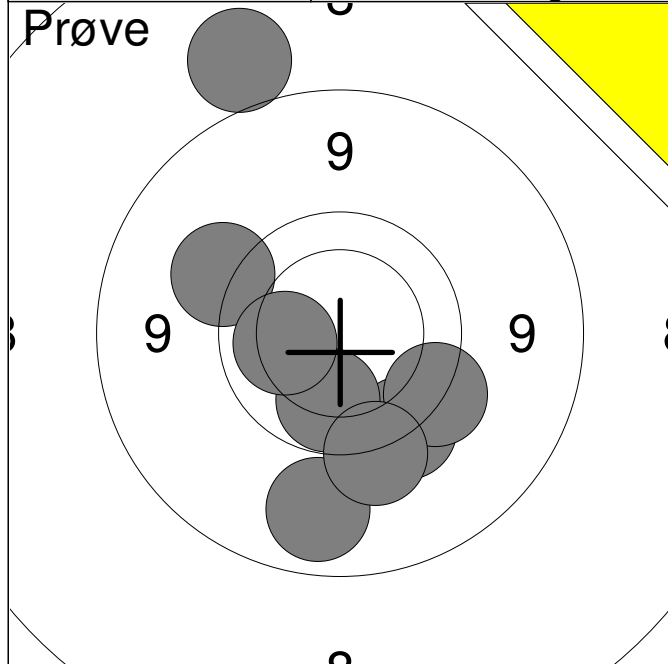

1:	9.1	↓
2:	8.4	↑
3:	9.4	↗
4:	9.6	↓
5:	9.6	↓
6:	10.0	↓
7:	10.1	←
8:	9.5	↓
Serie		73.0
Total		0.0

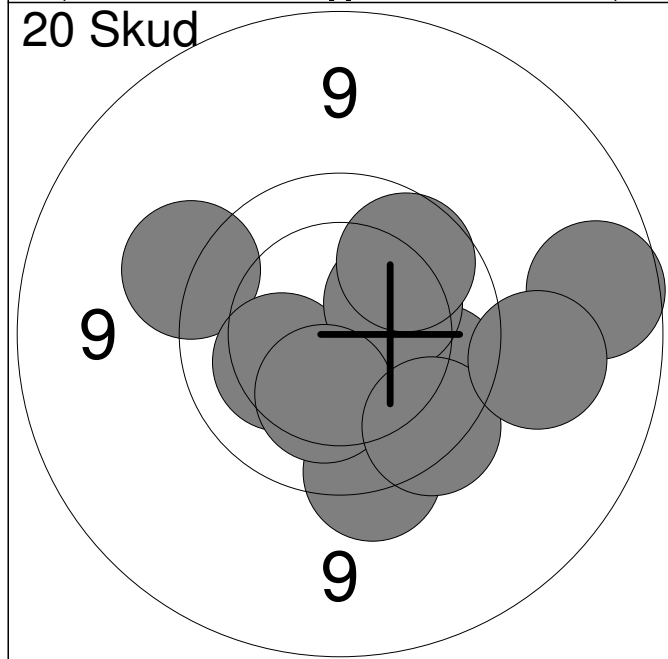

1:	8.9	→
2:	9.5	↖
3:	10.2	↙
4:	9.9	↘
5:	10.3	↗
6:	9.9	↗
7:	9.6	↓
8:	10.3	↓
9:	9.7	↓
10:	9.3	→
Serie		92.0
Total		92.0

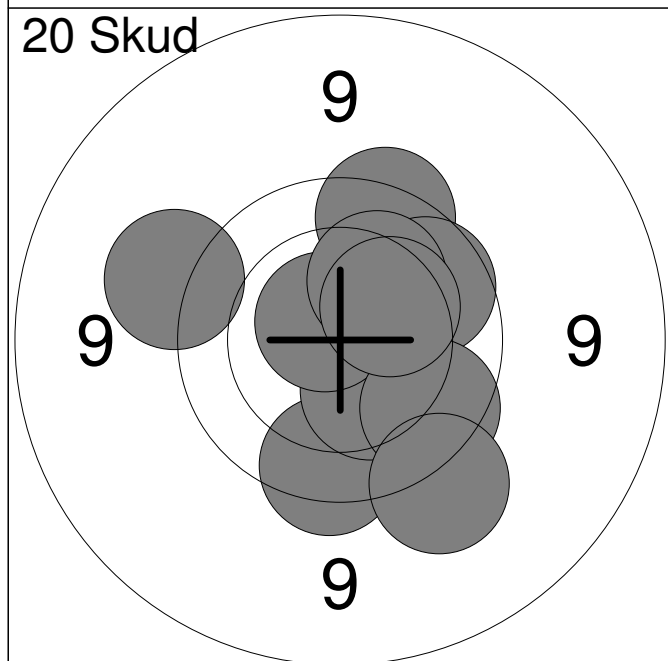

11:	9.7	↓
12:	10.3	↓
13:	9.7	↑
14:	*10.7	↗
15:	9.9	↗
16:	9.4	↖
17:	10.2	↗
18:	9.8	↓
19:	10.3	↗
20:	9.4	↓
Serie		94.0
Total		186.0

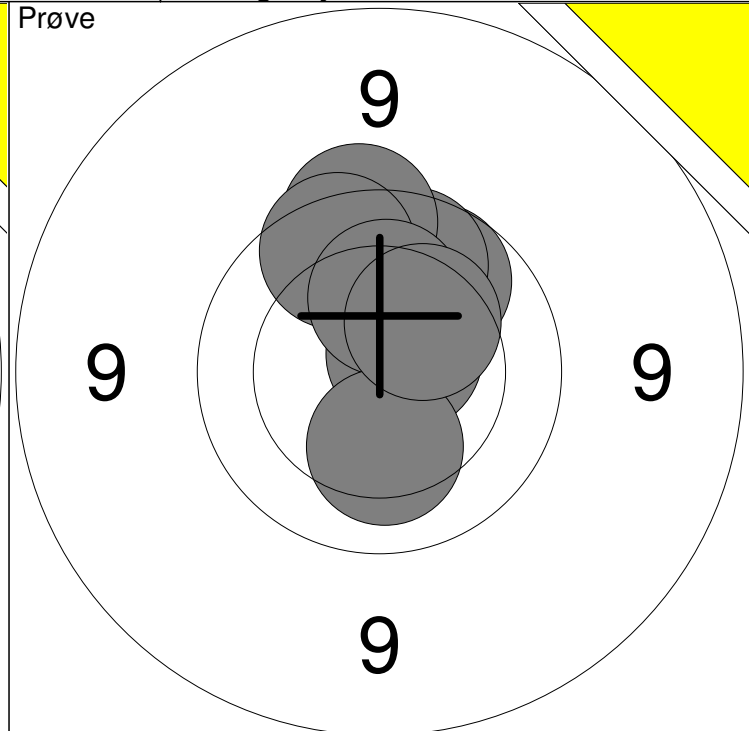
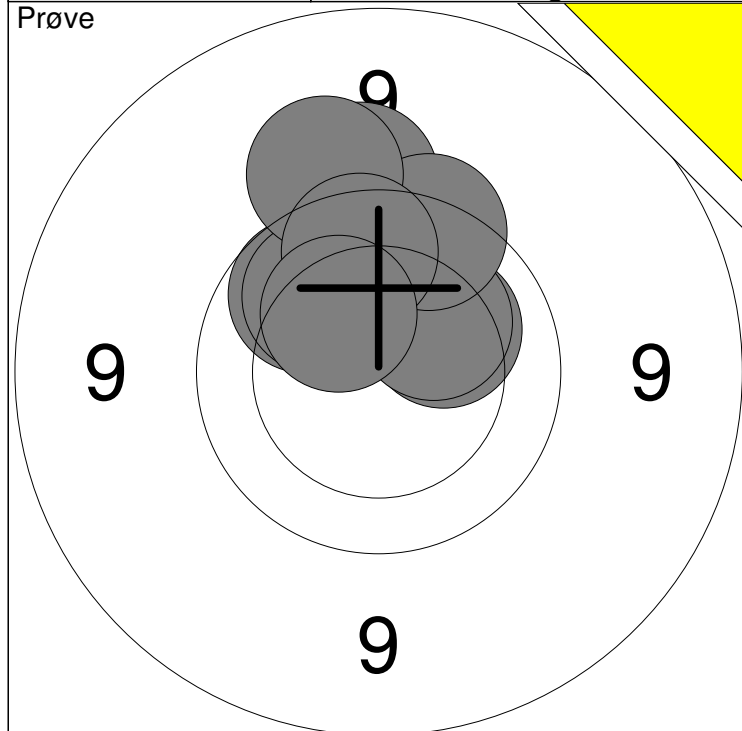

1: 9.7 ↑	6: 10.2 ↗	Serie	94.0
2: 9.9 ↘	7: 9.7 ↑		
3: 10.0 ↘	8: 9.4 ↑	Total	0.0
4: 9.5 ↑	9: 9.9 ↑		
5: 10.2 ↗	10: 10.3 ↘		

11: 9.9 ↗	16: 9.8 ↑	Serie	85.0
12: 9.9 ↑	17: 10.2 ↑		
13: 9.9 ↑	18: 10.2 ↓	Total	0.0
14: *10.7 ↗	19: 10.3 ↗		
15: 9.7 ↑			

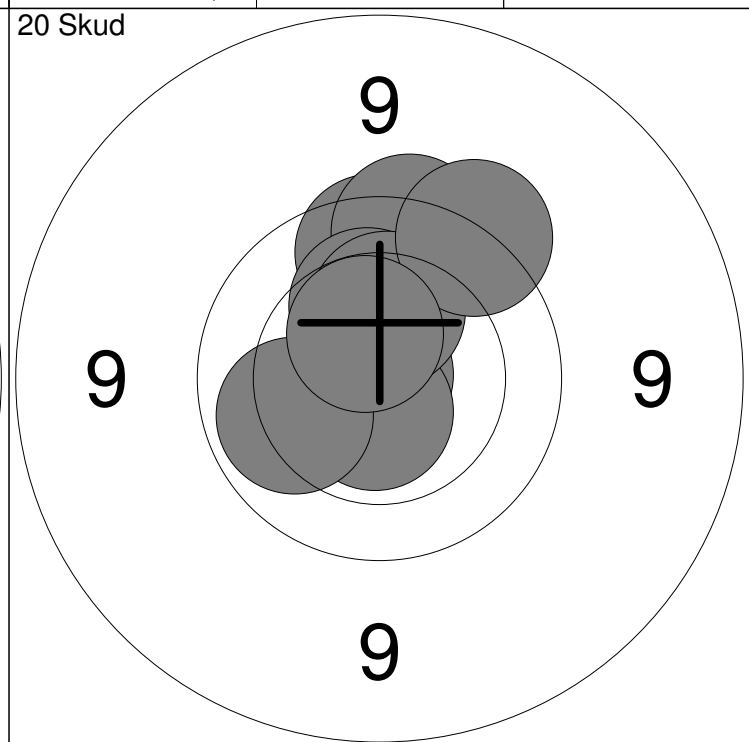
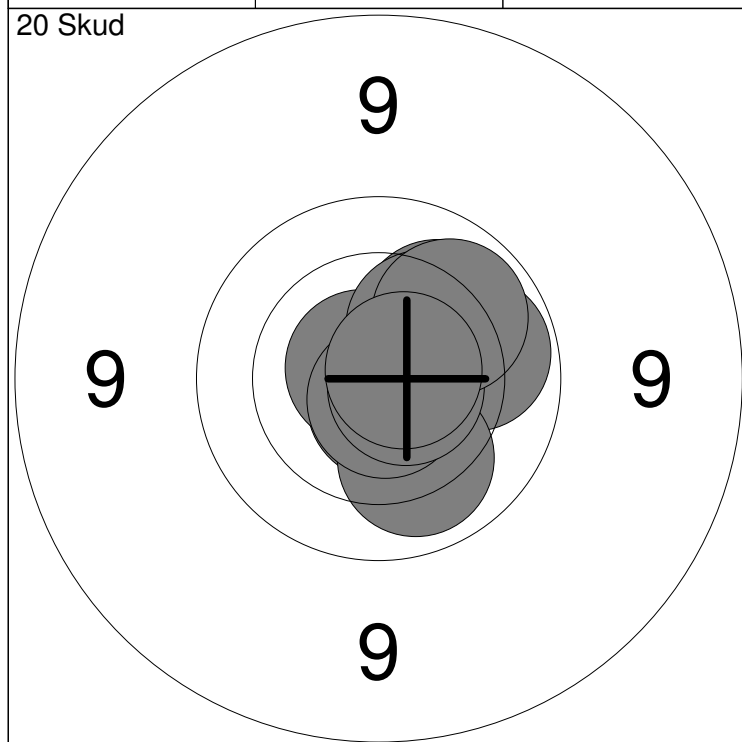

1: 10.1 ↗	6: *10.7 ↓	Serie	100.0
2: *10.7 ↓	7: 10.3 ↗		
3: 10.0 →	8: *10.7 →	Total	100.0
4: 10.1 ↓	9: 10.0 ↗		
5: *10.8 ↘	10: *10.7 →		

11: *10.6 ↗	16: 10.2 ↑	Serie	97.0
12: 9.8 ↑	17: 10.1 ↙		
13: *10.9 ↘	18: 10.3 ↑	Total	197.0
14: *10.6 ↓	19: 9.6 ↗		
15: 9.7 ↑	20: *10.5 ↗		

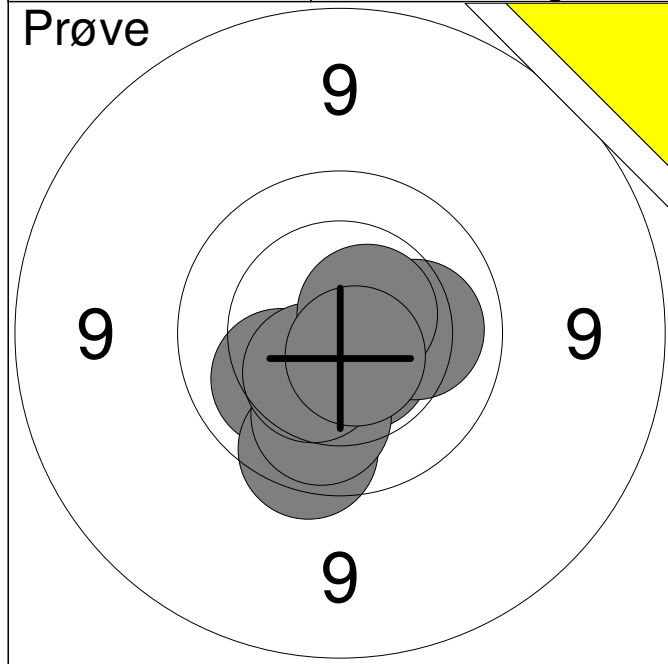

1:	*10.6	↘
2:	10.1	↙
3:	9.8	↘
4:	10.0	↘
5:	10.4	↙
6:	10.2	→
7:	*10.6	↗
8:	*10.7	↘
Serie		79.0
Total		0.0

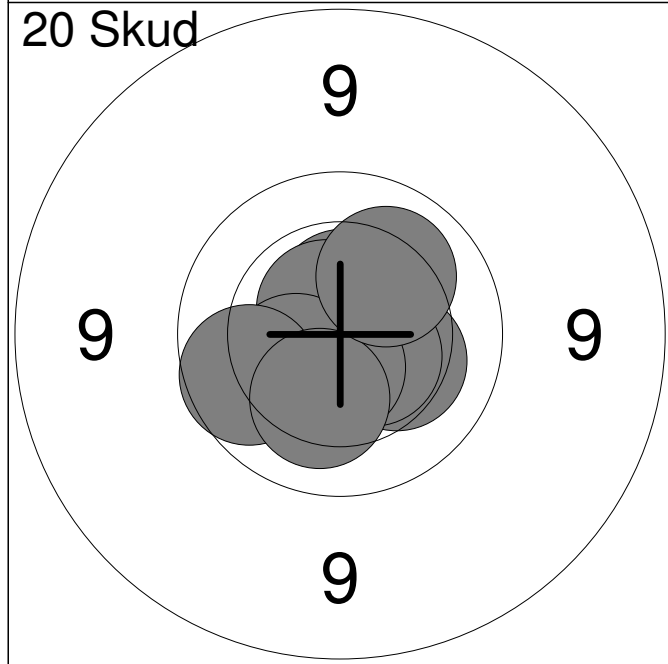

1:	*10.6	↑
2:	10.3	→
3:	*10.5	↘
4:	*10.6	↙
5:	*10.6	↗
6:	*10.6	↘
7:	10.4	↙
8:	9.9	↙
9:	10.2	↘
10:	10.2	↗
Serie		99.0
Total		99.0

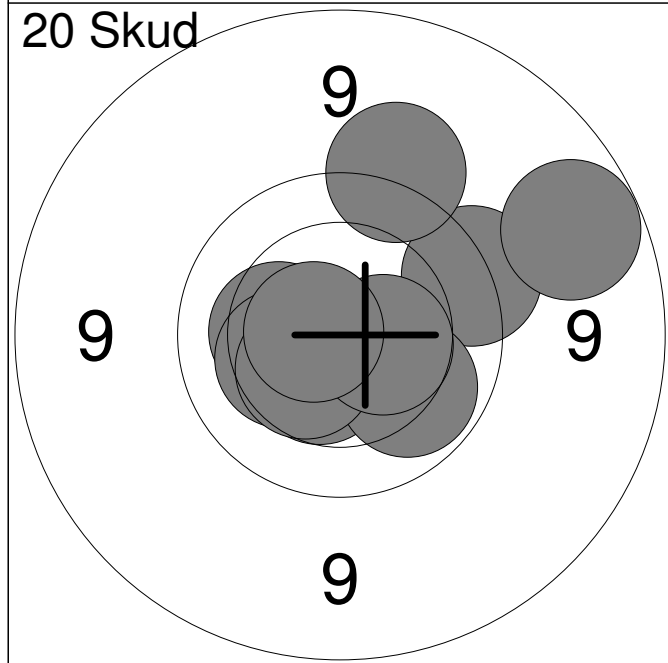

11:	10.3	←
12:	10.5	↘
13:	9.6	↗
14:	10.0	↘
15:	10.3	↙
16:	9.0	↗
17:	10.4	↙
18:	10.5	→
19:	*10.7	←
20:	9.5	↑
Serie		97.0
Total		196.0

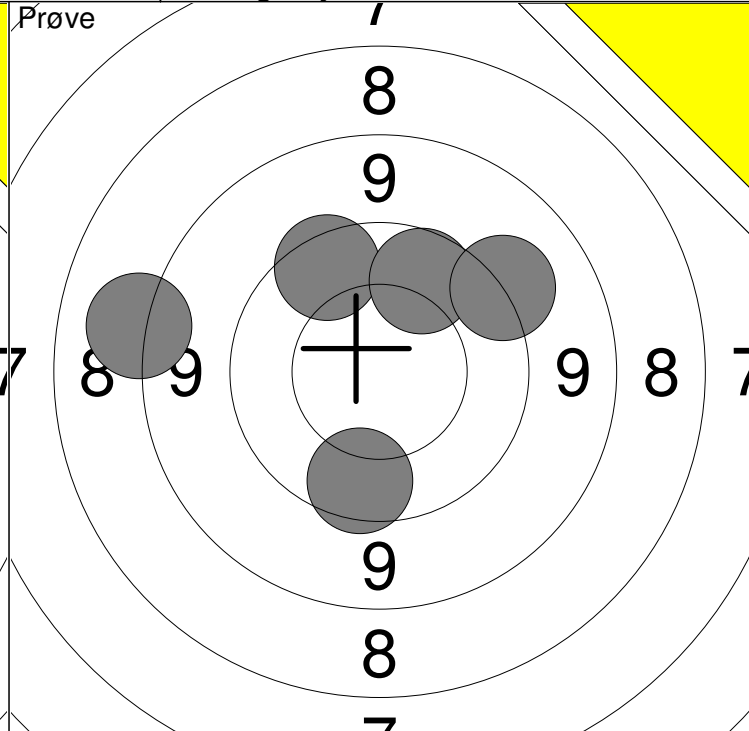
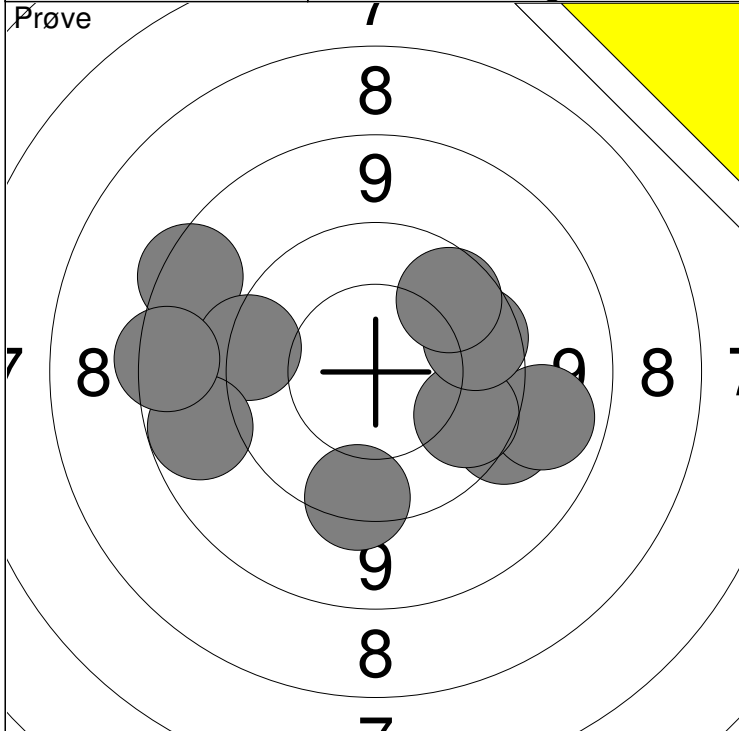

1: 9.4 →	6: 9.9 ↗	Serie	88.0
2: 9.1 →	7: 8.7 ↖		
3: 9.6 ↓	8: 9.6 ←	Total	0.0
4: 9.9 →	9: 9.0 ←		
5: 9.9 →	10: 8.7 ←		

11: 9.7 ↖	Serie	44.0
12: 9.9 ↗		
13: 9.4 ↗	Total	0.0
14: 8.3 ←		
15: 9.8 ↓		

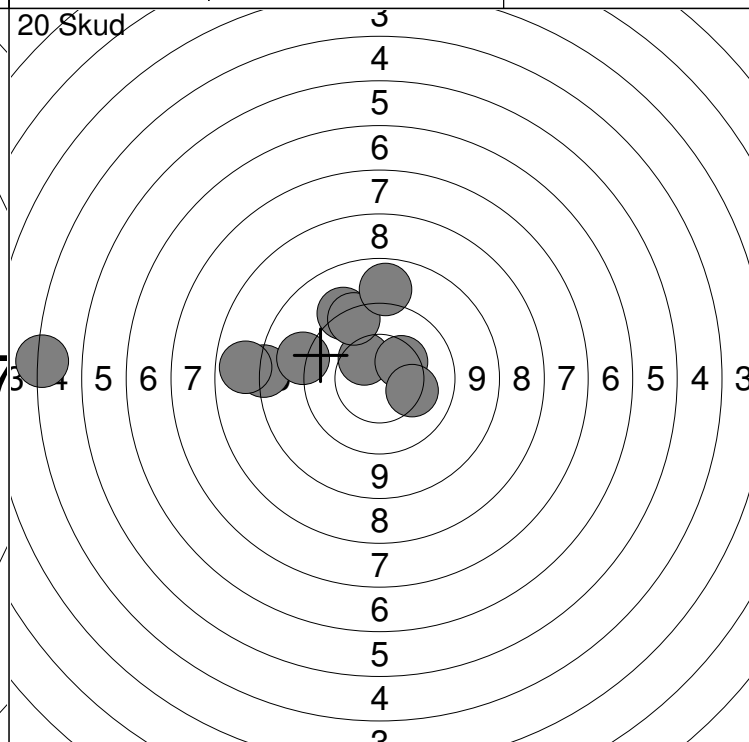
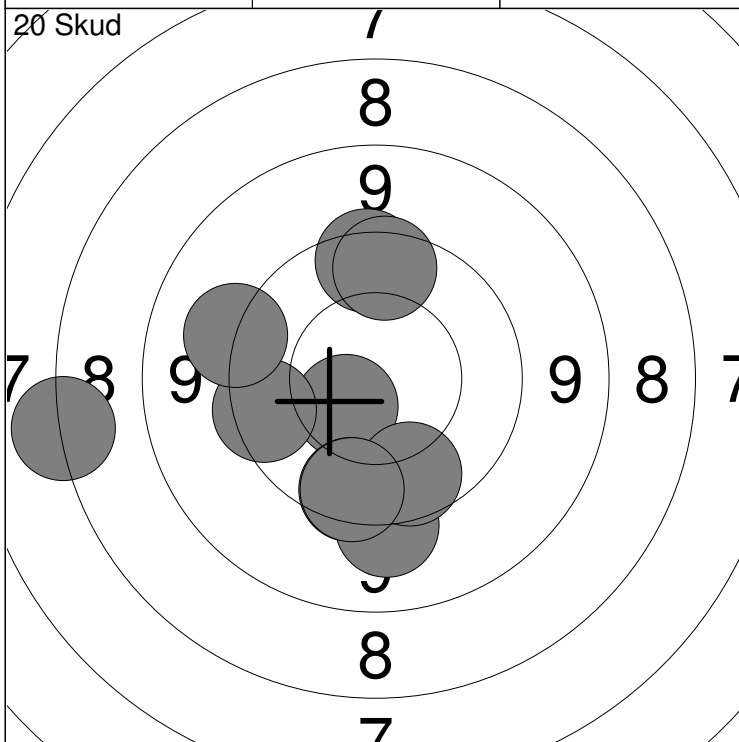

1: 10.5 ↖	6: 9.7 ↓	Serie	89.0
2: 9.7 ↓	7: 9.7 ↑		
3: 9.4 ↓	8: 9.4 ←	Total	89.0
4: 9.9 ↓	9: 7.4 ←		
5: 9.7 ←	10: 9.8 ↑		

11: 8.4 ←	16: 9.6 ↗	Serie	85.0
12: 3.5 ←	17: 9.3 ←		
13: 10.4 ↖	18: 9.0 ↑	Total	174.0
14: 9.4 ↗	19: 10.4 ↗		
15: 8.0 ←	20: 10.2 →		

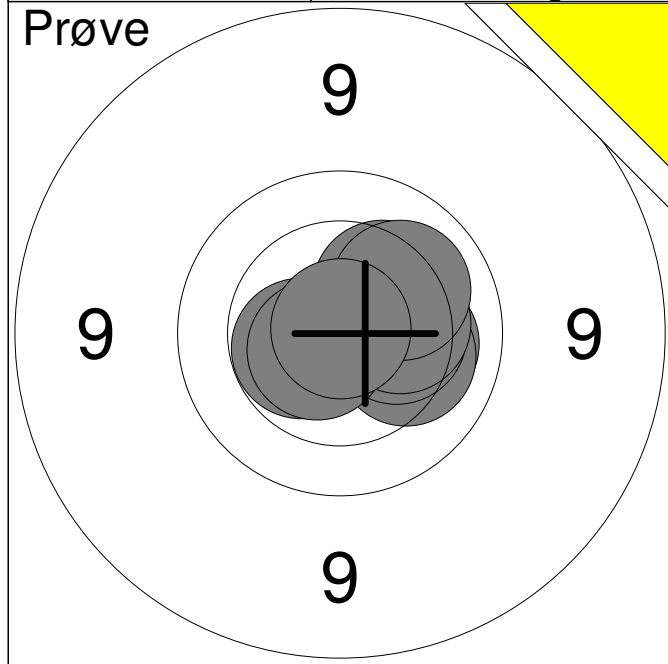

1:	10.2	→
2:	10.2	→
3:	10.3	→
4:	10.3	↗
5:	10.3	→
6:	10.2	↗
7:	*10.5	←
8:	*10.6	↙
9:	*10.9	↑
Serie		90.0
Total		0.0

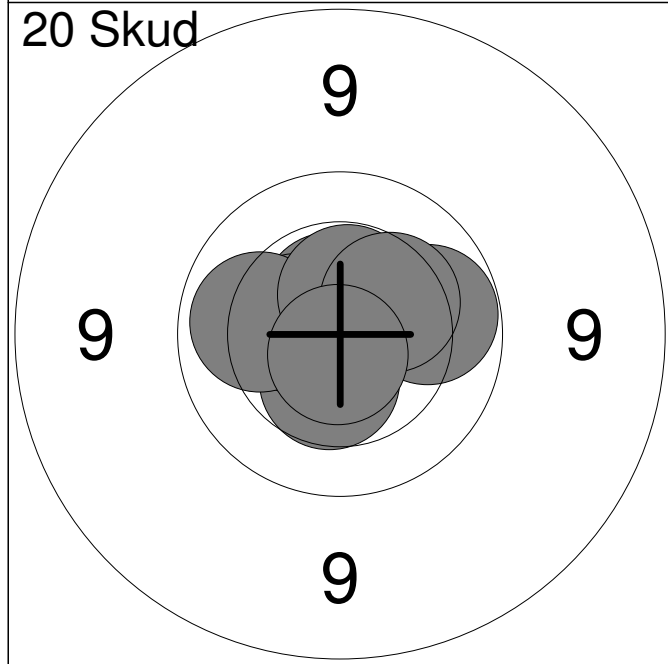

1:	*10.8	↗
2:	10.4	↓
3:	*10.8	→
4:	*10.6	↑
5:	10.5	←
6:	10.1	←
7:	10.0	→
8:	*10.5	↑
9:	10.3	↗
10:	*10.7	↓
Serie		100.0
Total		100.0

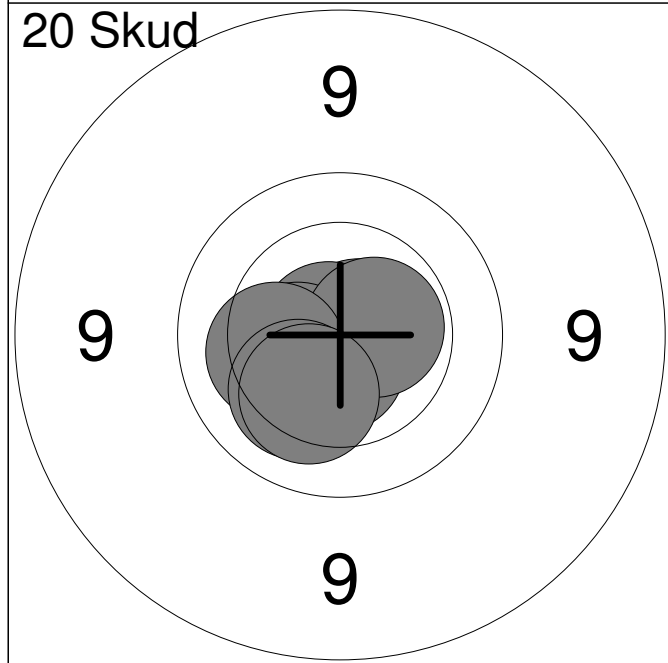

11:	*10.7	↙
12:	*10.6	↓
13:	*10.9	↑
14:	*10.7	→
15:	*10.8	←
16:	10.5	←
17:	*10.6	→
18:	10.2	←
19:	10.2	↙
20:	10.2	↙
Serie		100.0
Total		200.0

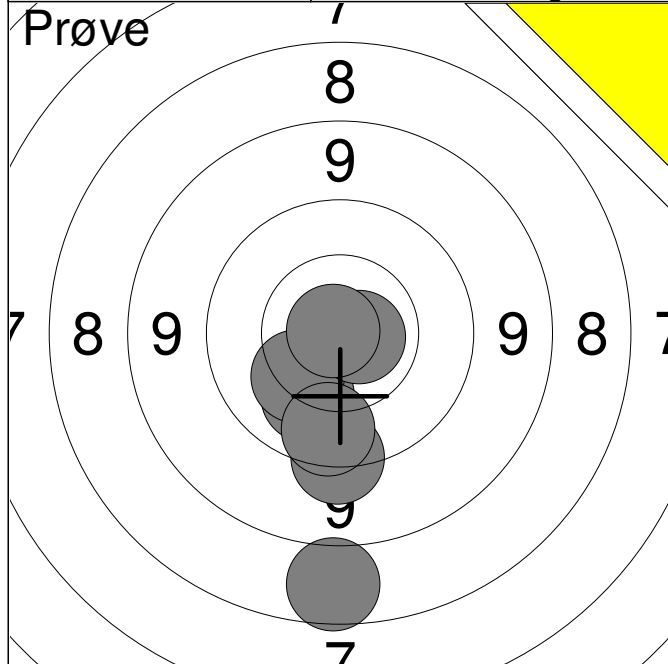

1:	9.5	↓
2:	10.1	↙
3:	7.9	↓
4:	10.2	↙
5:	9.8	↓
6:	*10.7	→
7:	*10.9	↖
Serie		65.0
Total		0.0

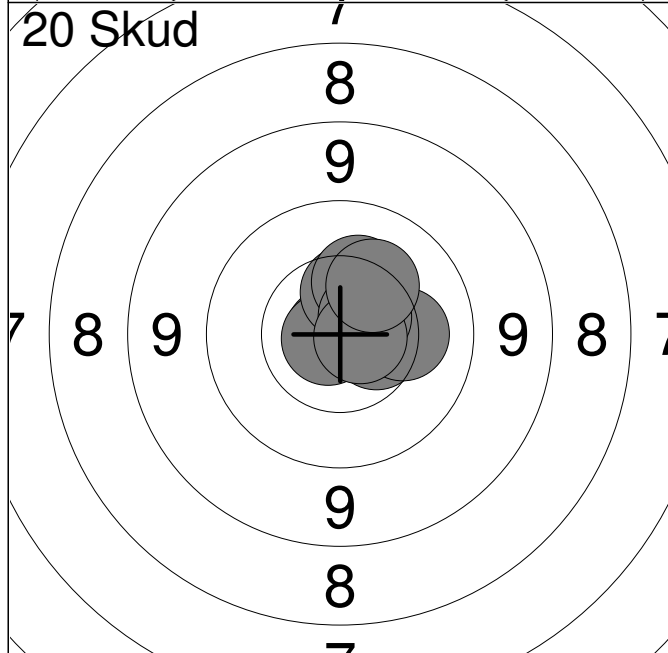

1:	*10.9	←
2:	*10.8	→
3:	10.5	→
4:	*10.8	←
5:	10.5	↑
6:	10.3	↑
7:	10.2	→
8:	*10.6	↗
9:	*10.7	→
10:	10.3	↗
Serie		100.0
Total		100.0

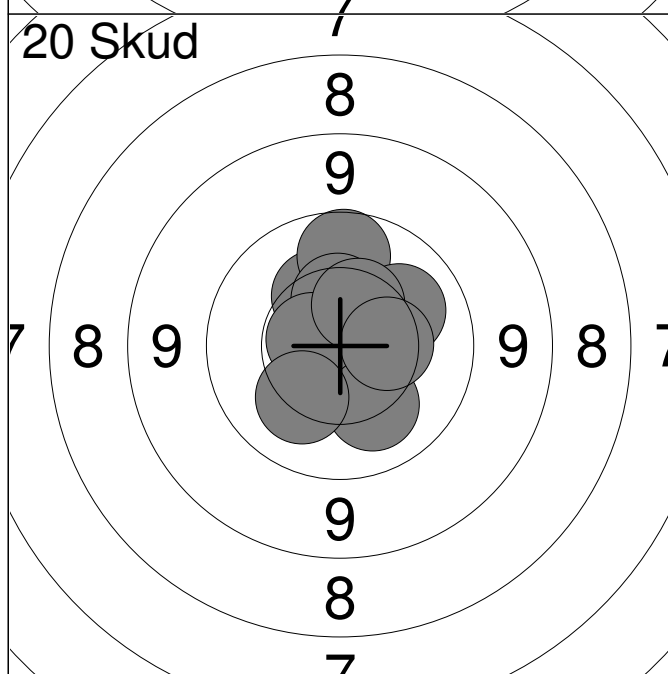

11:	10.6	↗
12:	10.3	↖
13:	9.9	↑
14:	10.4	↑
15:	10.1	↗
16:	*10.6	←
17:	10.2	↓
18:	10.4	↑
19:	10.2	↙
20:	10.4	→
Serie		99.0
Total		199.0

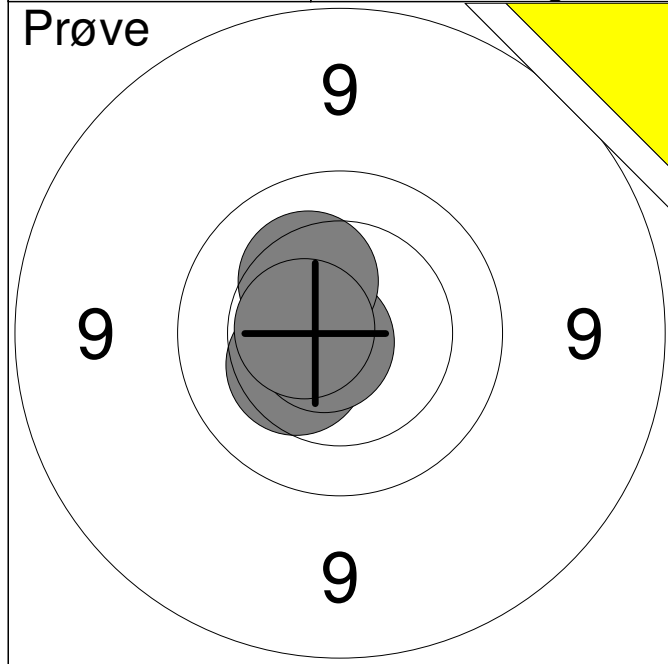

1:	*10.6	↖
2:	10.4	↙
3:	*10.7	↘
4:	10.3	↗
5:	*10.6	↖
Serie		50.0
Total		0.0

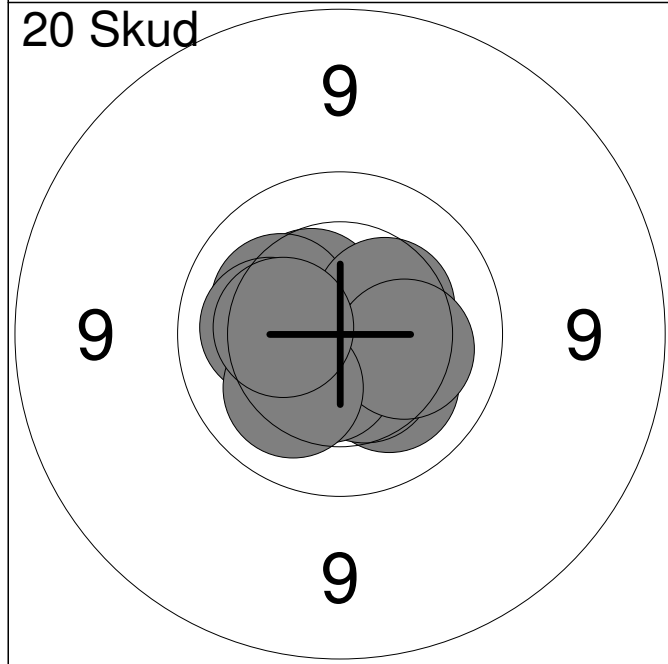

1:	10.5	↗
2:	10.2	↗
3:	10.2	↘
4:	10.4	↗
5:	10.5	↘
6:	*10.5	↘
7:	10.2	→
8:	10.2	←
9:	10.2	↙
10:	10.3	←
Serie		100.0
Total		100.0

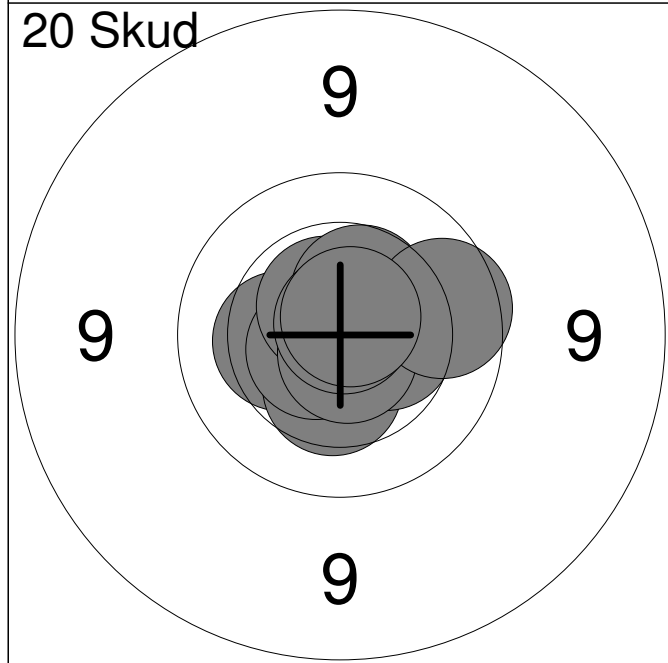

11:	10.3	←
12:	10.4	↓
13:	10.5	→
14:	*10.6	↙
15:	*10.6	↗
16:	*10.7	↘
17:	10.5	↗
18:	9.9	→
19:	*10.8	↗
20:	*10.7	↗
Serie		99.0
Total		199.0

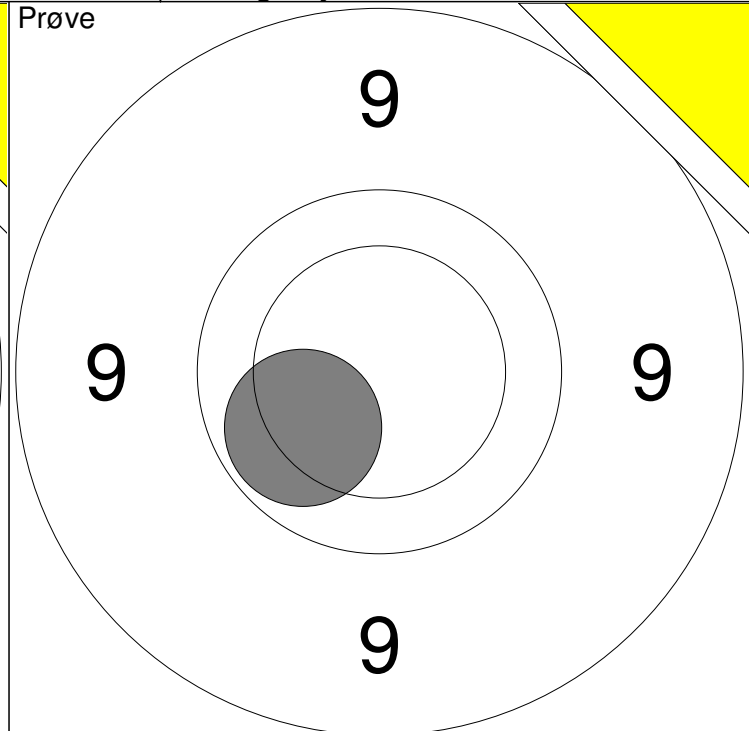
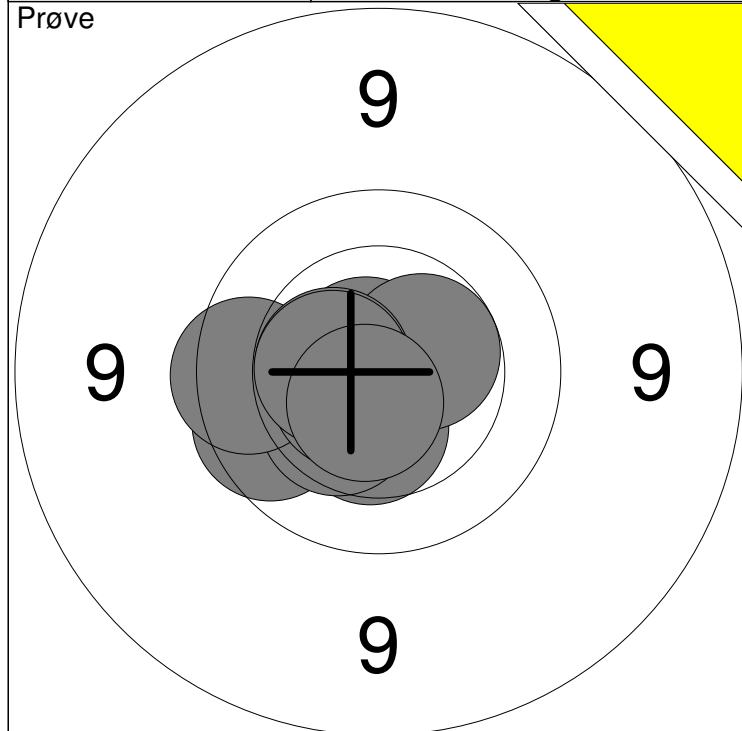

1: *10.7 ↖	6: 9.8 ←	Serie	98.0
2: 9.9 ←	7: *10.5 ↖		
3: 10.4 ↓	8: *10.6 ↙	Total	0.0
4: 10.4 ↙	9: *10.5 ↖		
5: *10.5 →	10: *10.6 ↙		

11: 10.0 ↙	Serie	10.0
	Total	0.0

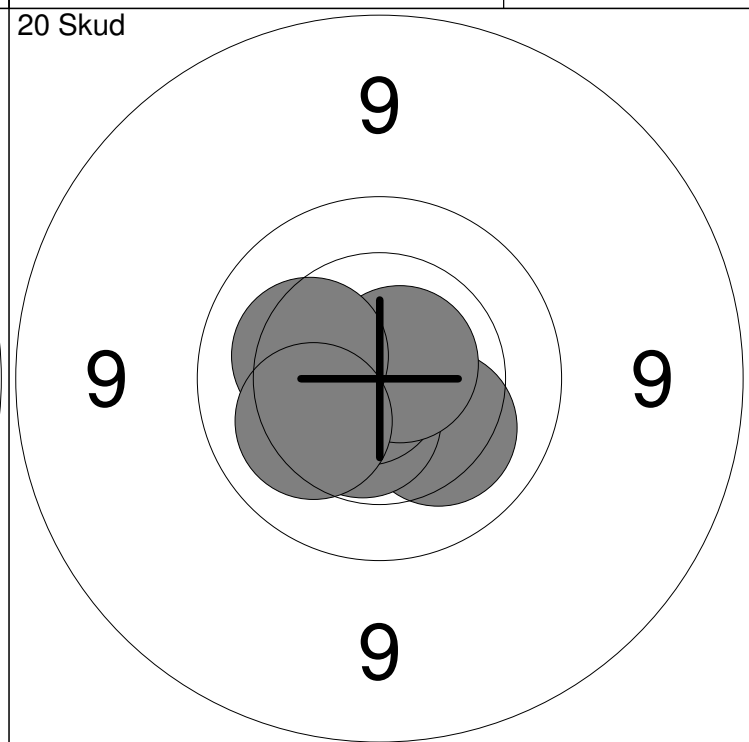
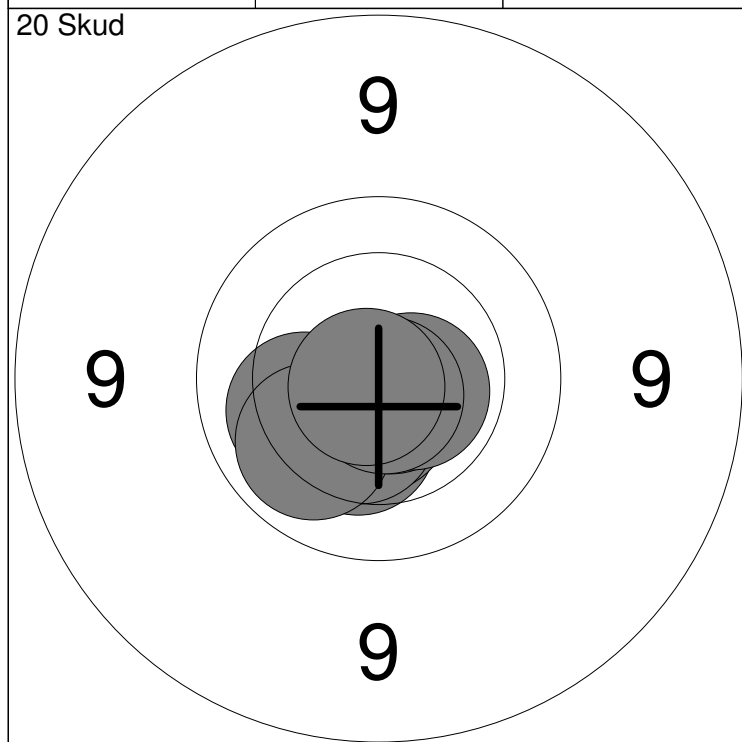

1: 10.4 ↓	6: *10.8 ↘	Serie	100.0
2: *10.6 ↓	7: 10.1 ↙		
3: *10.6 ↓	8: *10.6 →	Total	100.0
4: 10.2 ←	9: *10.8 ↘		
5: 10.5 ↓	10: *10.8 ↙		

11: *10.9 ↖	16: *10.5 ↓	Serie	100.0
12: *10.7 ↙	17: *10.8 ↖		
13: *10.6 ↘	18: *10.7 →	Total	200.0
14: 10.4 ←	19: 10.2 ←		
15: 10.2 ↘	20: 10.2 ↙		

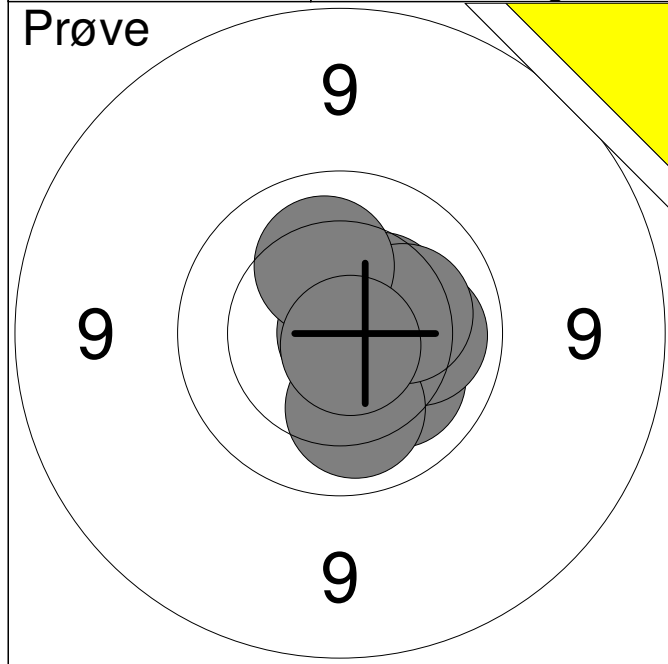

1:	10.2	↘
2:	10.1	→
3:	10.4	↗
4:	*10.9	→
5:	10.1	↓
6:	10.2	→
7:	10.2	↑
8:	*10.8	↘
Serie		80.0
Total		0.0

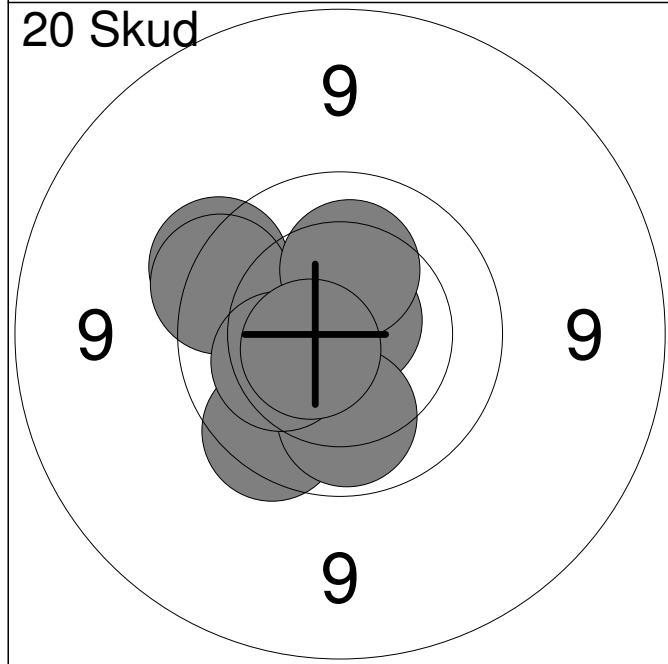

1:	*10.8	↗
2:	10.1	↘
3:	10.3	↙
4:	9.7	↖
5:	9.8	↘
6:	9.7	↖
7:	10.1	↓
8:	10.3	↑
9:	10.2	↙
10:	*10.6	↙
Serie		97.0
Total		97.0

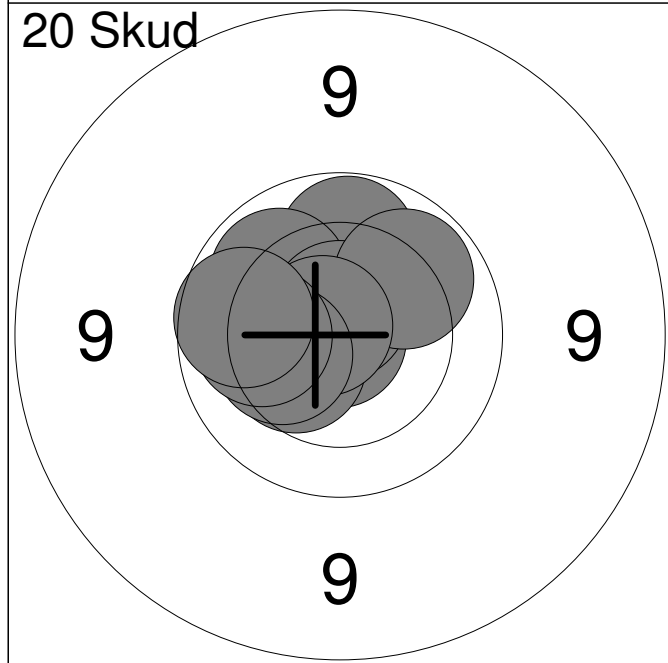

11:	10.0	↑
12:	*10.9	↙
13:	10.4	↙
14:	10.1	↖
15:	*10.7	↑
16:	10.0	↗
17:	*10.7	↖
18:	10.3	↙
19:	10.1	↙
20:	9.9	↙
Serie		99.0
Total		196.0

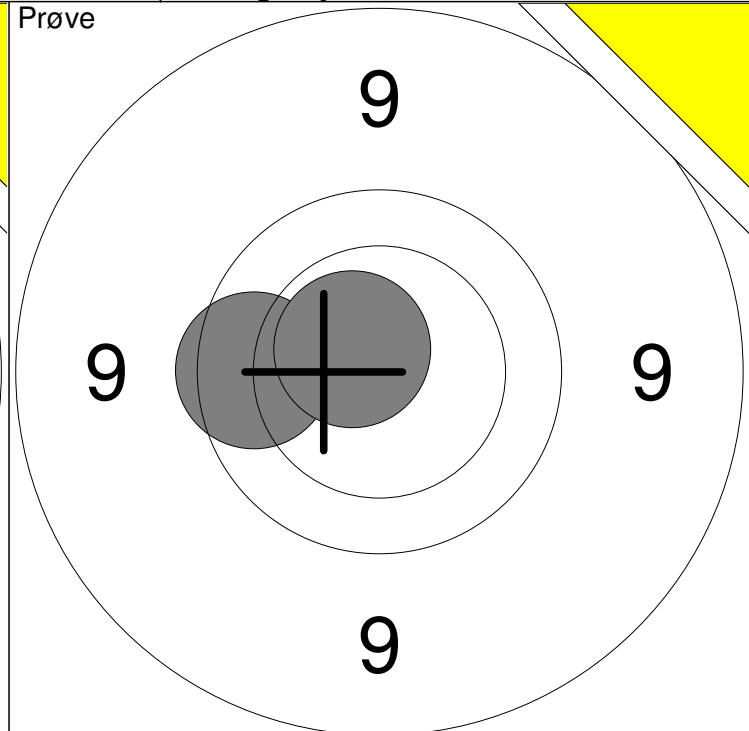
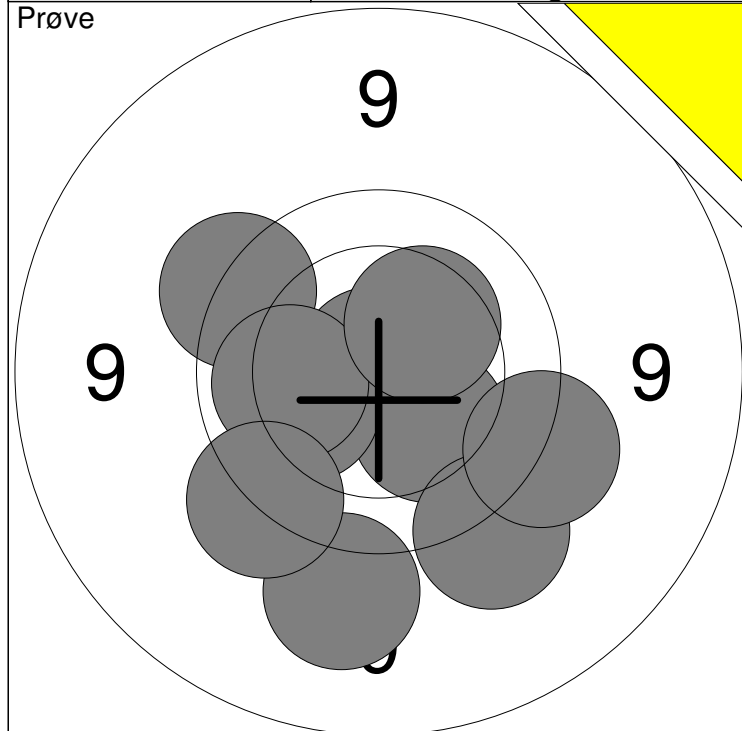

1: *10.9 ↖	6: 10.1 ←	Serie	95.0
2: 10.2 ↘	7: 10.3 ↗		
3: 10.2 ←	8: 9.6 ↙	Total	0.0
4: 9.3 ↓	9: 9.4 ↘		
5: 9.6 ↖	10: 9.5 ↗		

11: 9.8 ←	Serie	19.0
12: *10.6 ↖		
	Total	0.0

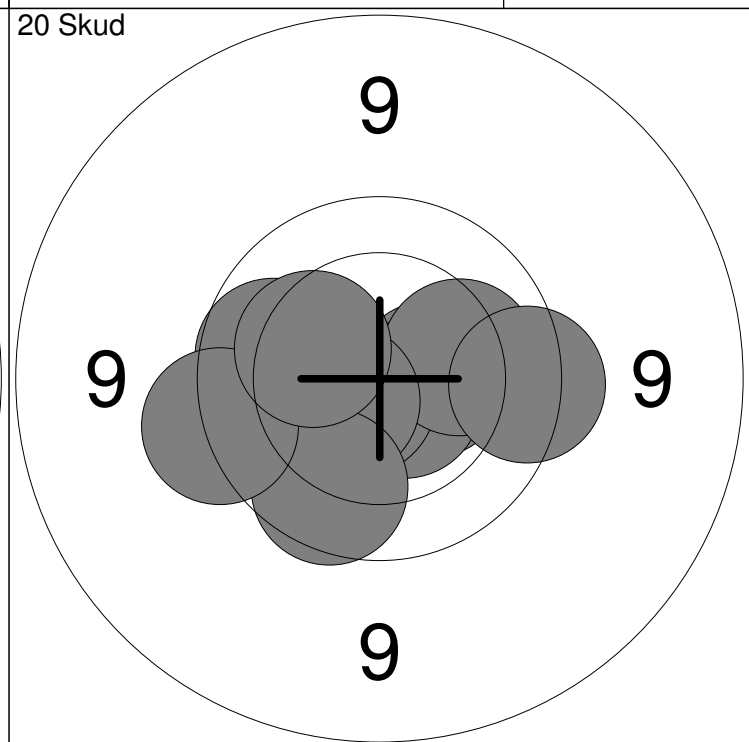
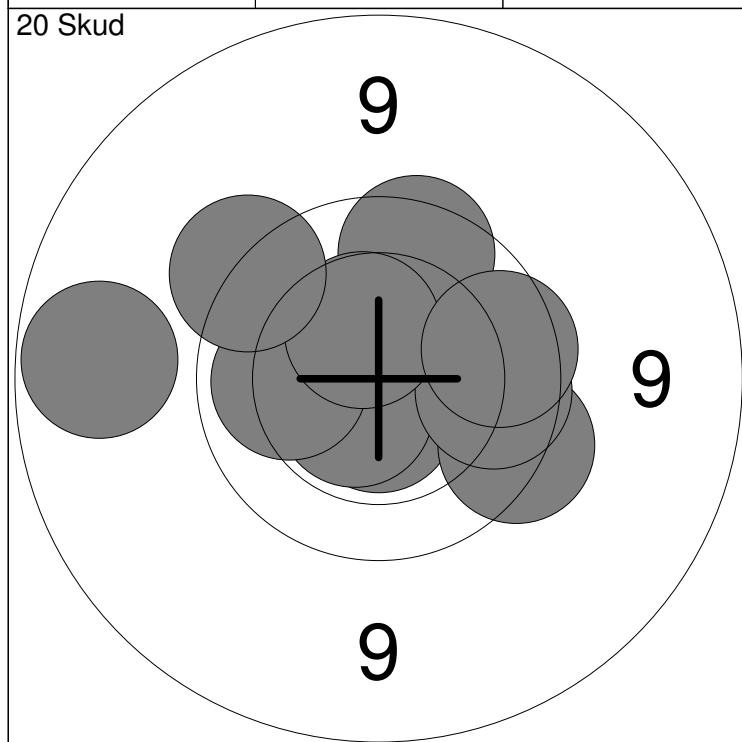

1: *10.6 ↓	6: 9.0 ←	Serie	94.0
2: 9.8 ↑	7: 10.1 ←		
3: *10.6 ↙	8: 10.5 ↑	Total	94.0
4: 9.7 →	9: 9.6 ↖		
5: 9.9 →	10: 9.8 →		

11: 10.5 →	16: *10.5 ↙	Serie	96.0
12: *10.6 ↘	17: 9.9 ←		
13: *10.7 ↙	18: 9.9 ↓	Total	190.0
14: 10.2 →	19: 9.6 ←		
15: 9.7 →	20: 10.3 ↖		

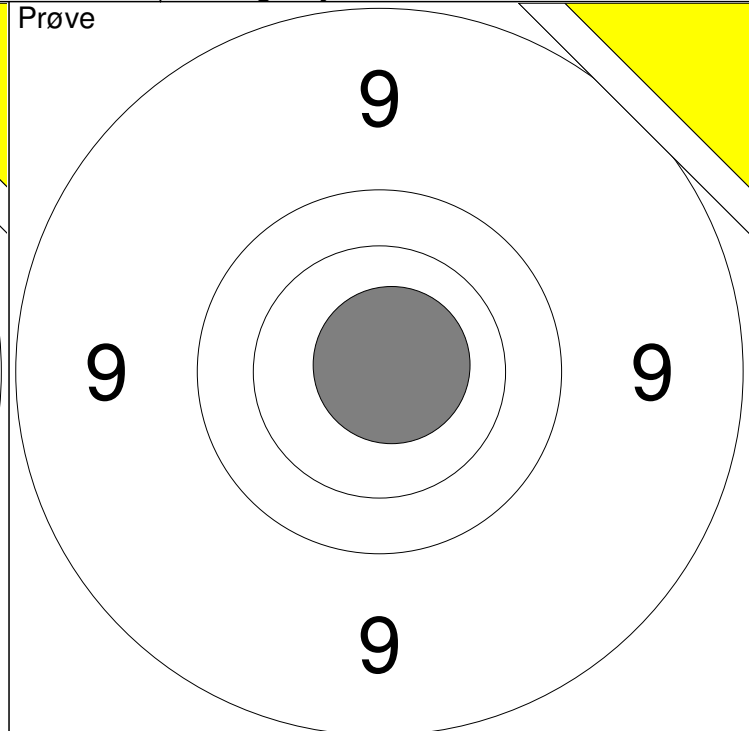
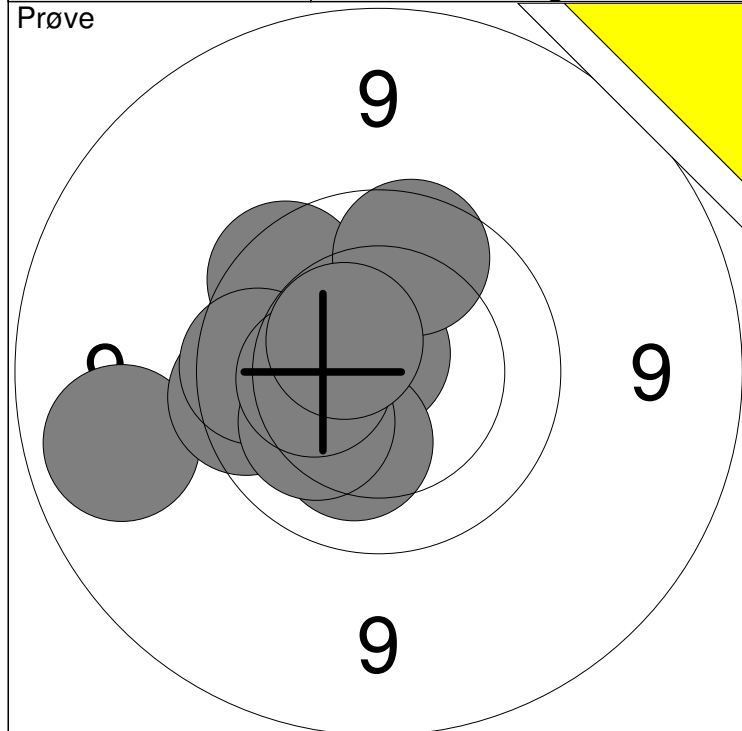

1: 9.1 ←	6: 10.2 ↓	Serie	95.0
2: 9.8 ←	7: 10.2 ↙		
3: *10.8 ↗	8: 10.3 ←	Total	0.0
4: 9.8 ↖	9: 9.9 ↑		
5: 9.9 ←	10: *10.5 ↘		

11: *10.8 ↗		Serie	10.0
		Total	0.0

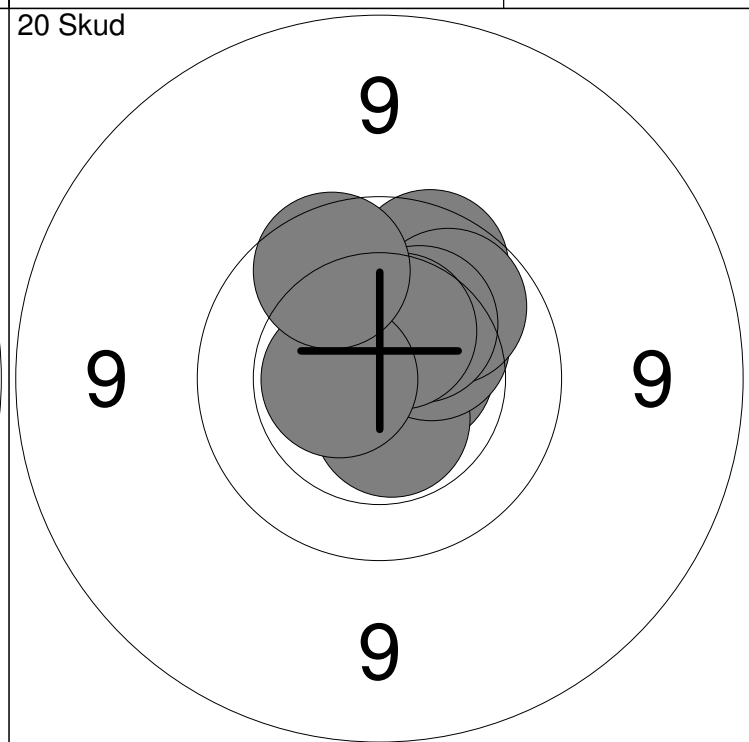
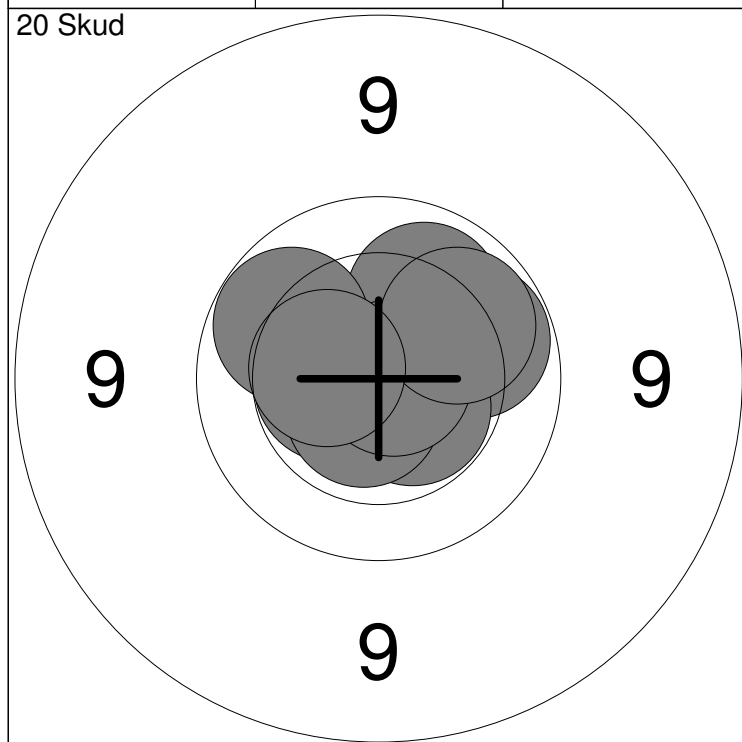

1: 10.0 →	6: *10.6 ↓	Serie	100.0
2: *10.5 ↙	7: *10.8 →		
3: *10.7 ↑	8: 10.0 ↖	Total	100.0
4: 10.1 ↗	9: 10.0 ↗		
5: *10.5 ↘	10: 10.4 ←		

11: 9.9 ↑	16: 10.0 ↗	Serie	98.0
12: *10.6 ↑	17: 10.3 ↗		
13: *10.6 →	18: 10.5 ↑	Total	198.0
14: *10.5 ↓	19: *10.6 ↙		
15: 10.3 ↗	20: 9.9 ↑		

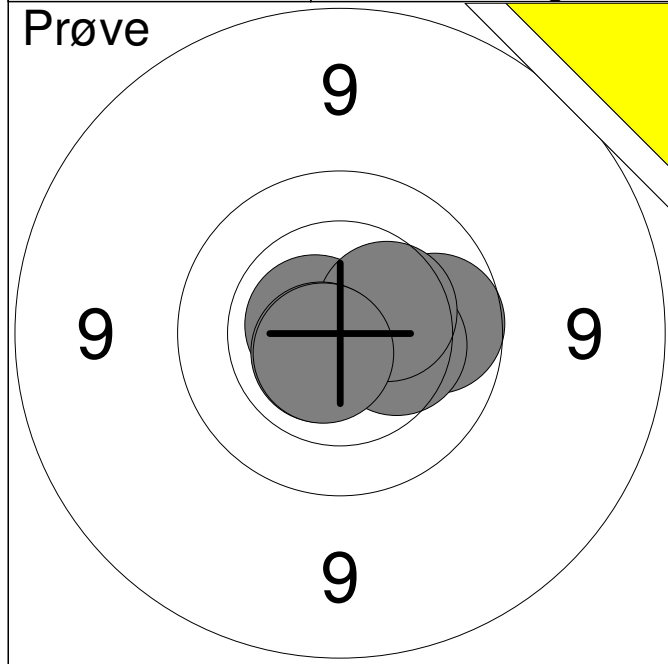

1:	*10.7	↖
2:	9.9	→
3:	10.3	→
4:	10.4	→
5:	*10.7	↙
6:	*10.7	↙
Serie		59.0
Total		0.0

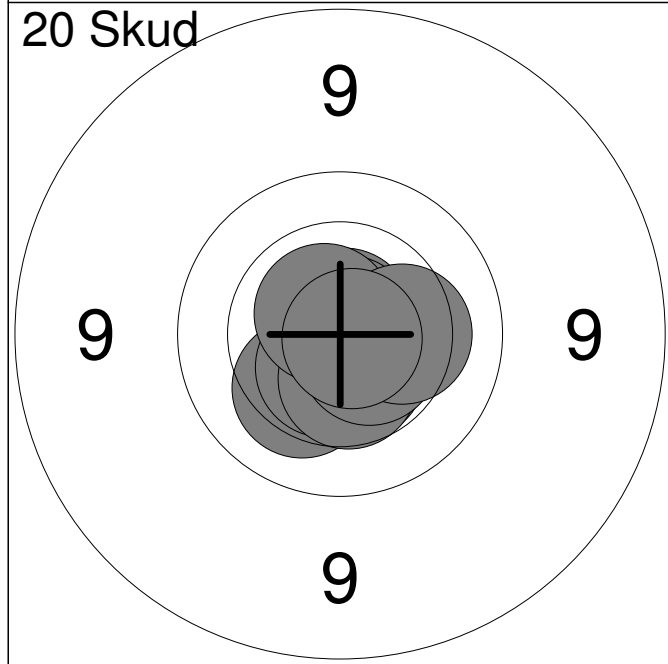

1:	10.2	↙
2:	*10.5	↘
3:	*10.8	↑
4:	*10.6	↙
5:	10.5	↘
6:	*10.6	↘
7:	*10.8	↗
8:	*10.7	↗
9:	10.3	→
10:	*10.8	→
Serie		100.0
Total		100.0

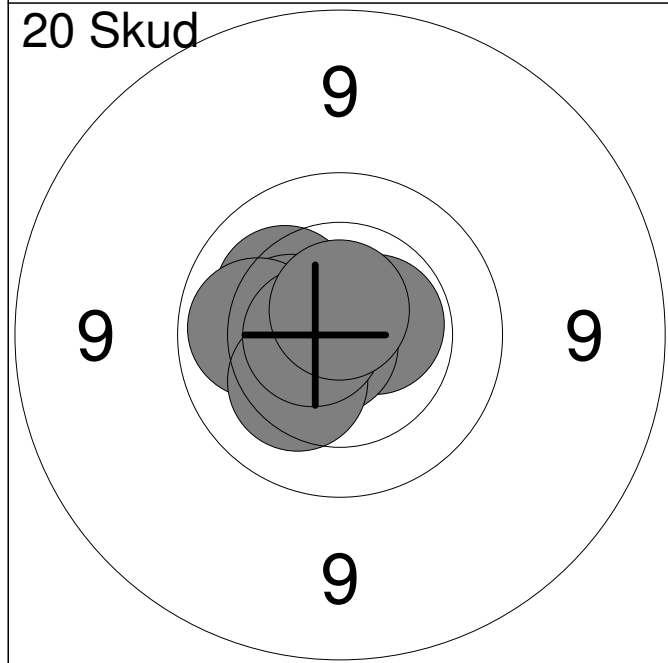

11:	10.4	↖
12:	*10.8	↗
13:	*10.6	→
14:	10.2	↗
15:	10.4	↖
16:	10.1	↖
17:	*10.8	↙
18:	10.3	↙
19:	*10.7	←
20:	*10.7	↑
Serie		100.0
Total		200.0

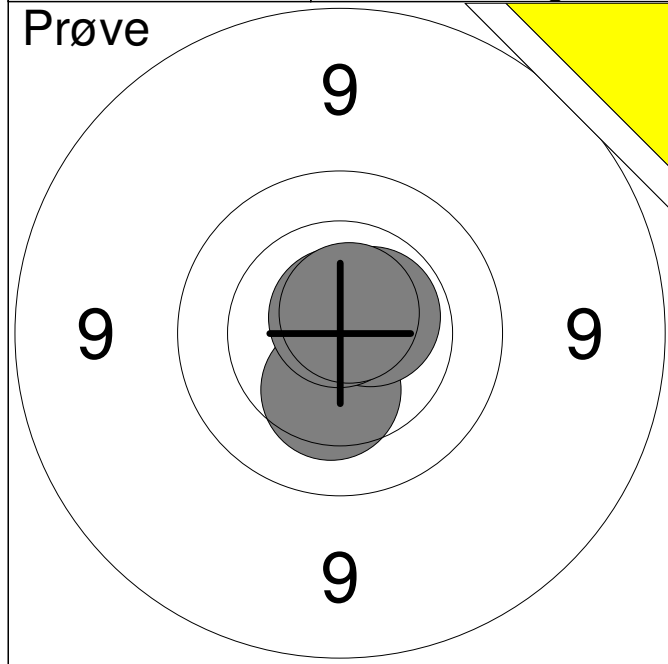

1:	10.3	↓
2:	*10.6	→
3:	*10.8	↑
4:	*10.7	↗
Serie		40.0
Total		0.0

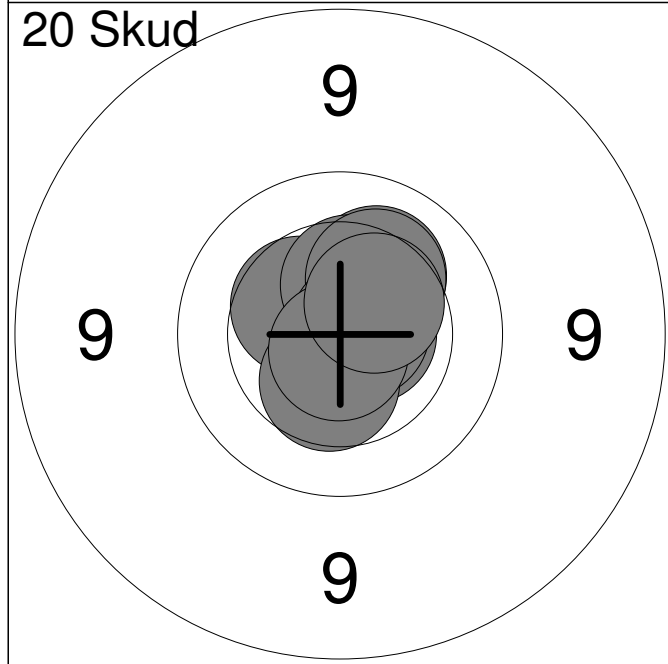

1:	*10.7	→
2:	10.5	↗
3:	10.4	↖
4:	10.2	↗
5:	10.4	↑
6:	10.2	↗
7:	*10.7	→
8:	10.4	↓
9:	*10.8	↓
10:	10.4	↗
Serie		100.0
Total		100.0

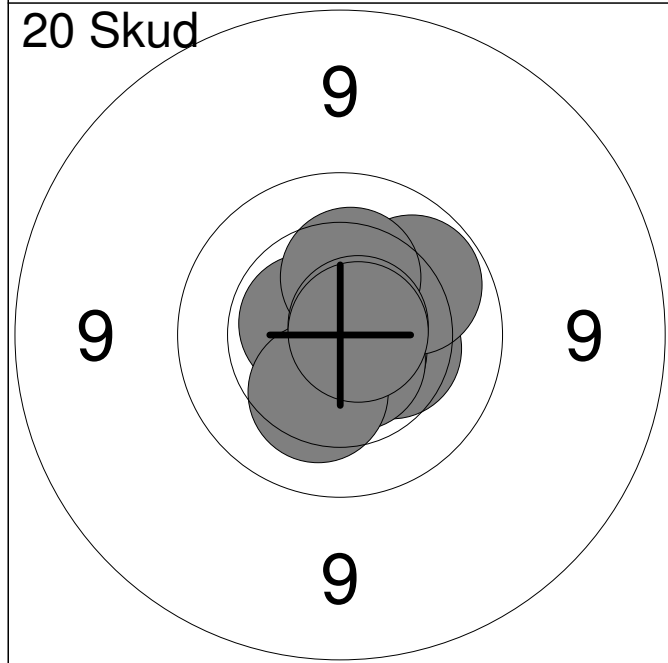

11:	10.4	→
12:	*10.7	↖
13:	*10.6	↖
14:	*10.7	↓
15:	10.0	↗
16:	*10.6	↓
17:	10.3	↑
18:	10.3	↓
19:	*10.7	↗
20:	*10.8	→
Serie		100.0
Total		200.0

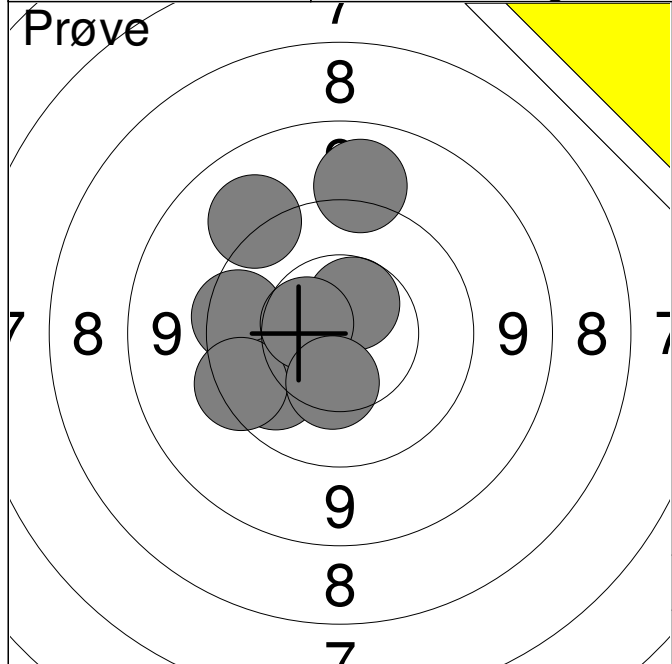

1:	9.3	↖
2:	9.7	←
3:	9.2	↑
4:	10.6	↗
5:	10.0	↙
6:	9.6	←
7:	10.6	↖
8:	10.4	↓
Serie		76.0
Total		0.0

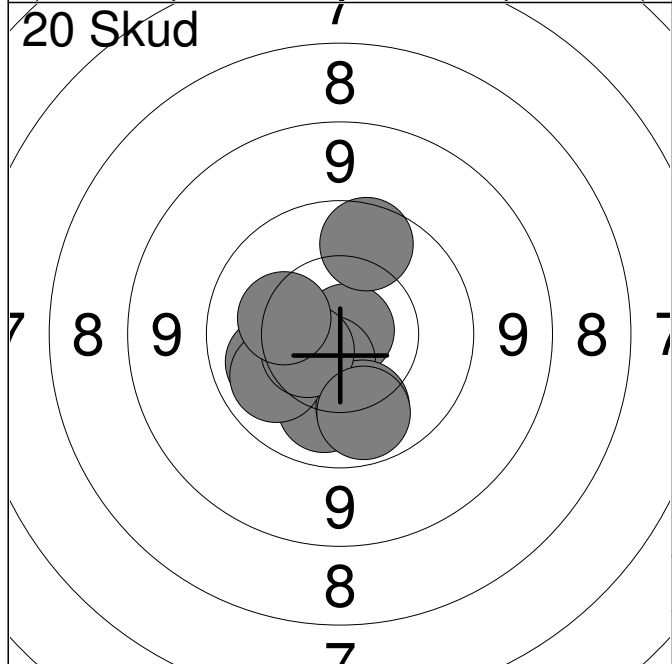

1:	*10.8	↗
2:	*10.6	↓
3:	10.1	←
4:	10.1	↓
5:	10.1	↓
6:	10.1	↙
7:	10.5	←
8:	10.3	←
9:	9.9	↑
10:	10.0	↓
Serie		99.0
Total		99.0

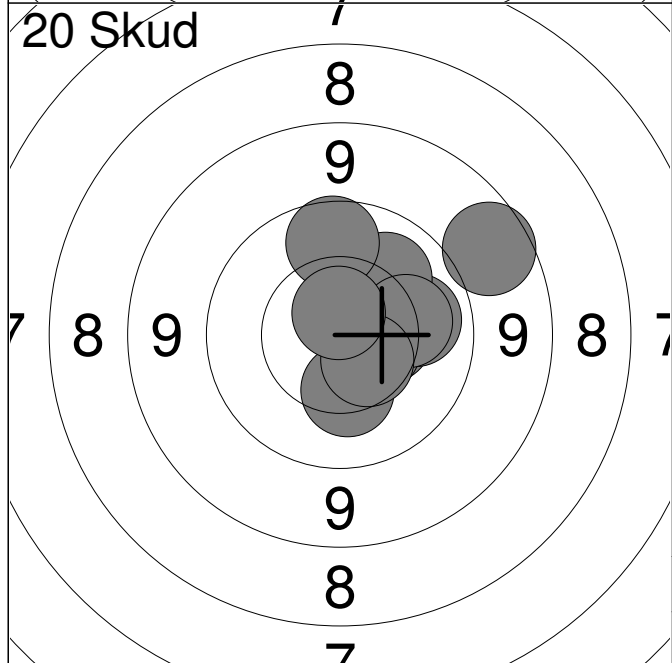

11:	10.3	↓
12:	10.4	→
13:	10.1	→
14:	10.5	→
15:	10.1	↗
16:	10.2	→
17:	8.9	↗
18:	10.5	↘
19:	9.9	↑
20:	*10.7	↑
Serie		97.0
Total		196.0

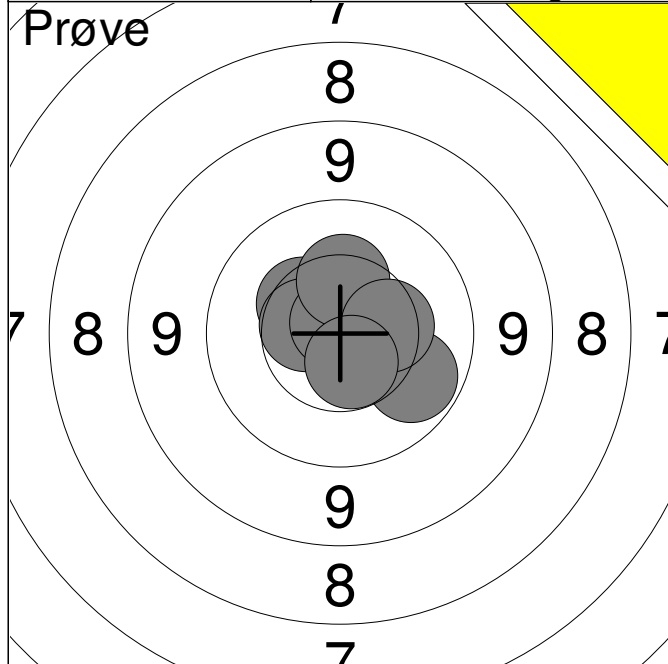

1:	10.0	↘
2:	10.4	↗
3:	10.5	←
4:	*10.8	↗
5:	10.3	↑
6:	10.4	→
7:	*10.6	↘
Serie		70.0
Total		0.0

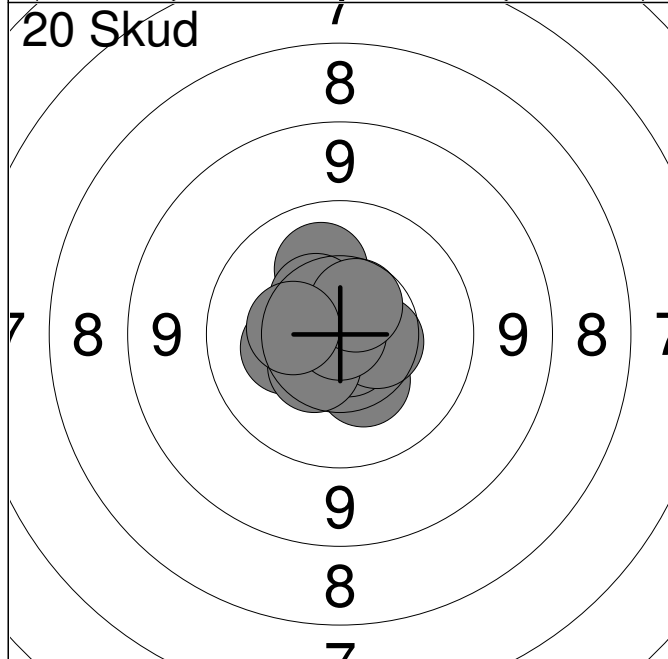

1:	10.4	↘
2:	10.2	↗
3:	*10.7	↘
4:	10.3	←
5:	10.5	→
6:	10.5	↘
7:	10.5	↗
8:	*10.9	↑
9:	10.6	↗
10:	10.4	←
Serie		100.0
Total		100.0

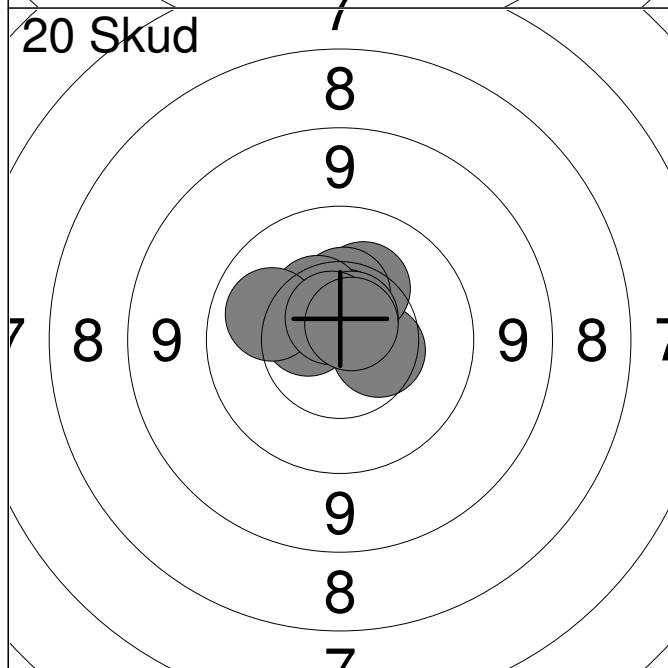

11:	10.6	←
12:	10.5	→
13:	10.3	↗
14:	10.4	↑
15:	*10.7	↑
16:	10.4	↗
17:	*10.7	↗
18:	10.1	←
19:	*10.7	↗
20:	*10.7	↗
Serie		100.0
Total		200.0

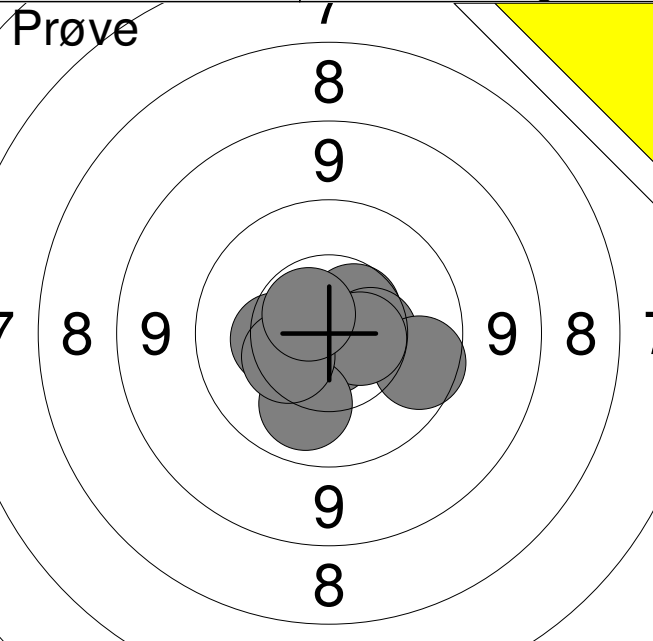
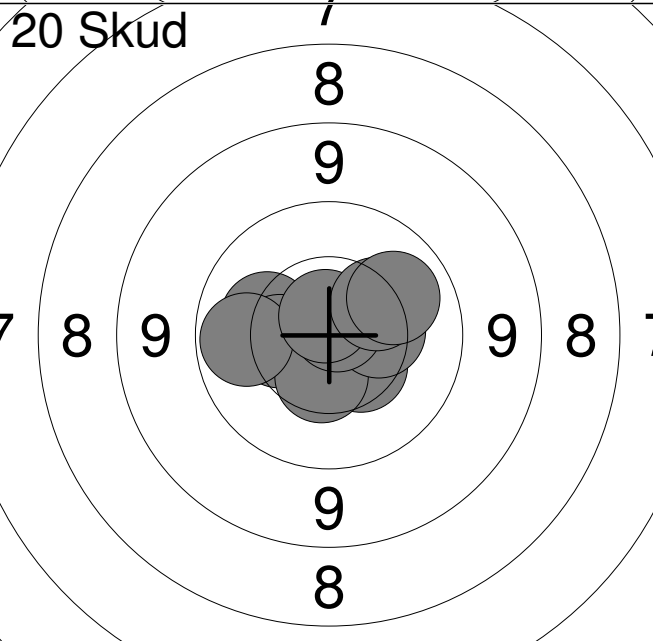
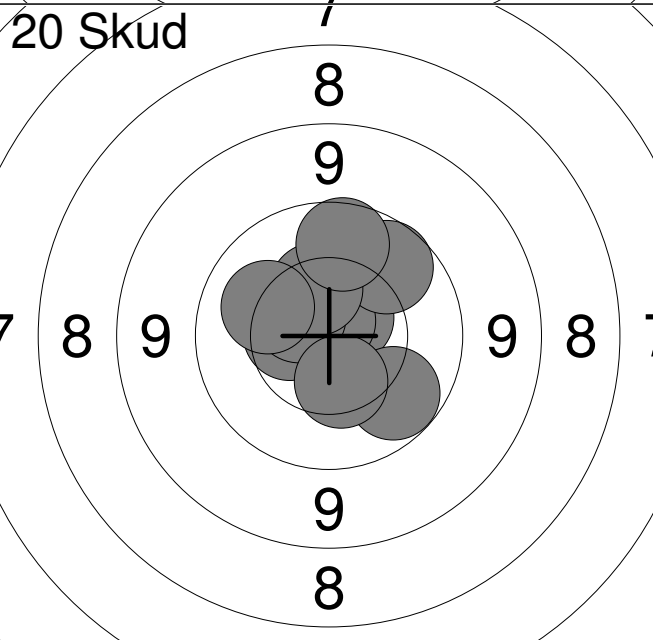
Hold	Skive	Kaj Mørk	
6	5	15m	Vester Hassing Skf. MJ1
1/3 - 3/3 2013	NM 15 meter Ungdom 2013	Aalborg Skyttekreds	
Prøve		1:	10.6 ↗
		2:	*10.8 ↓
		3:	10.5 →
		4:	9.8 ↘
		5:	*10.6 →
		6:	10.3 ←
		7:	10.1 ↓
		8:	10.4 ↙
		9:	*10.6 ↗
		Serie	
Total		0.0	
20 Skud		1:	10.2 ←
		2:	10.4 ←
		3:	10.4 ↘
		4:	10.5 ↓
		5:	10.4 →
		6:	10.0 ←
		7:	*10.8 ↗
		8:	*10.7 ↑
		9:	10.3 ↗
		10:	10.1 ↗
Serie		100.0	
Total		100.0	
20 Skud		11:	*10.7 ↗
		12:	10.5 ←
		13:	10.0 ↘
		14:	*10.8 ↑
		15:	10.5 ↘
		16:	9.9 ↗
		17:	10.4 ↑
		18:	10.2 ↙
		19:	9.9 ↑
		20:	10.4 ↓
Serie		98.0	
Total		198.0	

Hold 6	Skive 6	Kristian Thorhauge Hansen	
------------------	-------------------	----------------------------------	--

15m	Vester Han Herred Skytteforening MB4	MB4
-----	--------------------------------------	-----

1/3 - 3/3 2013	NM 15 meter Ungdom 2013	Aalborg Skyttekreds
----------------	-------------------------	---------------------

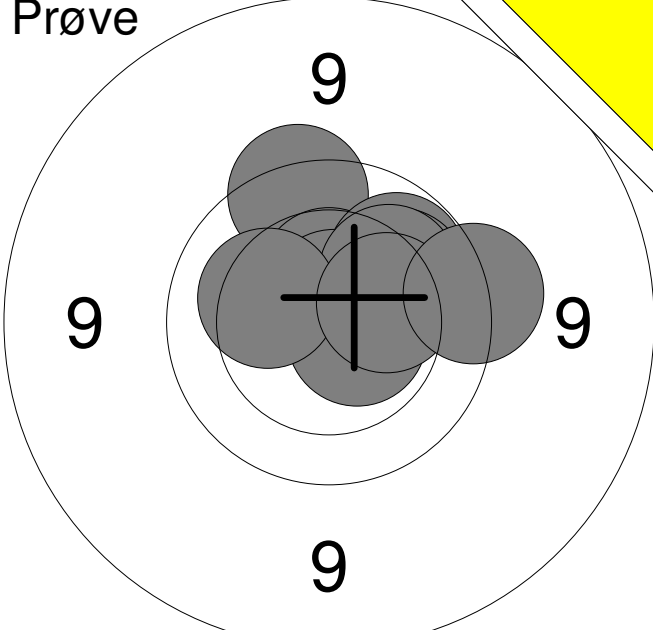
Prøve 	1: 9.7	↑
	2: 10.5	↑
	3: 10.0	↗
	4: *10.7	↑
	5: 10.1	↗
	6: 10.1	↗
	7: *10.6	↘
	8: 10.2	←
	9: 10.3	↗
	10: 9.6	→
	Serie	98.0
Total	0.0	

20 Skud 	1: 10.1	↑
	2: 9.3	←
	3: 10.4	↓
	4: 9.8	↑
	5: *10.7	↙
	6: 10.1	↙
	7: 10.5	↘
	8: *10.6	↑
	9: *10.7	←
	10: 9.7	↑
	Serie	97.0
Total	97.0	

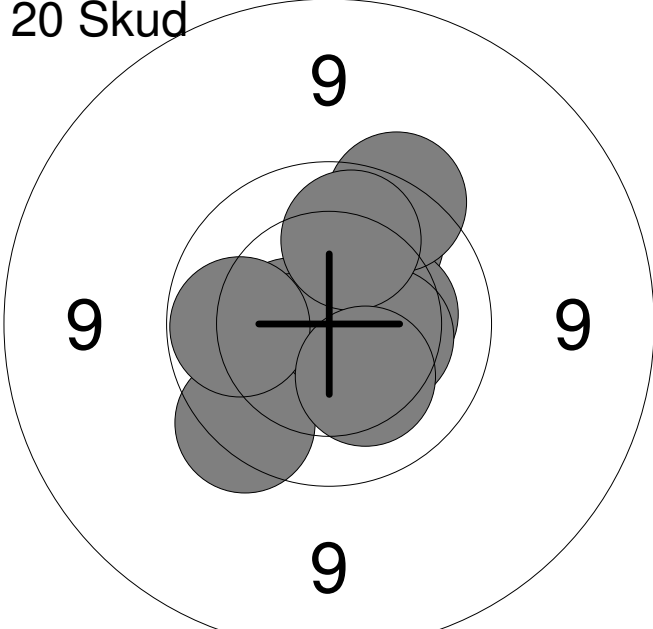
20 Skud 	11: 9.9	↗
	12: *10.6	←
	13: 10.3	→
	14: 10.3	→
	15: 9.7	↗
	16: *10.5	↙
	17: 10.0	↑
	18: 9.7	↙
	19: 10.0	←
	20: 10.3	↘
	Serie	97.0
Total	194.0	

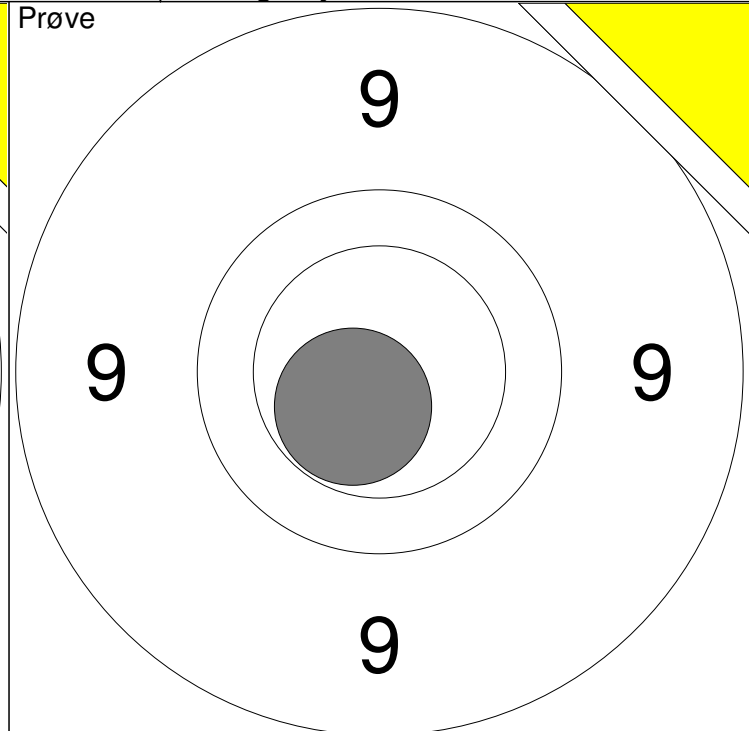
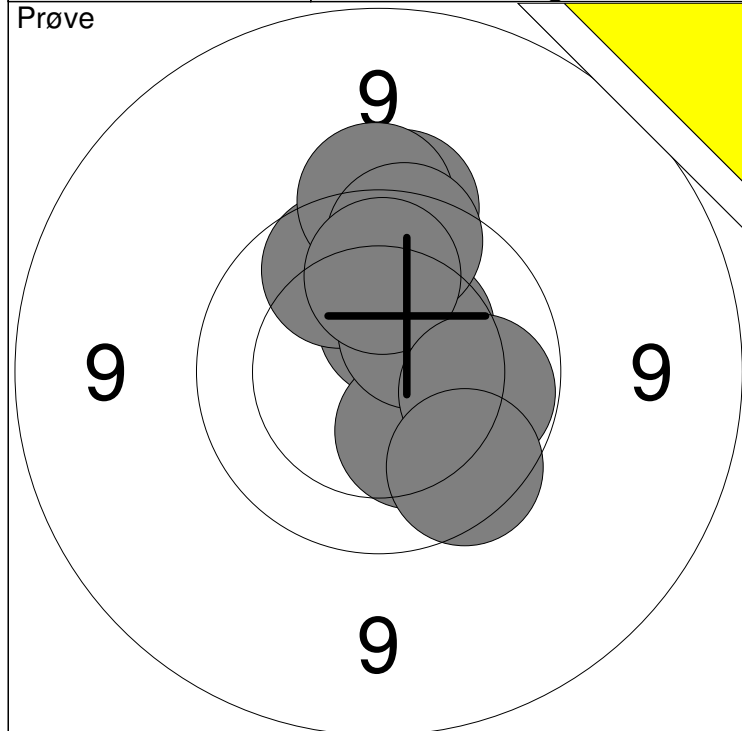

1: 9.6 ↑	6: 9.6 ↑	Serie	95.0
2: 10.4 ↑	7: 9.8 ↑		
3: 9.9 ↑	8: 10.0 ↑	Total	0.0
4: 10.3 ↓	9: 10.0 →		
5: 10.4 ↗	10: 9.8 ↓		

11: *10.5 ↙		Serie	10.0
		Total	0.0

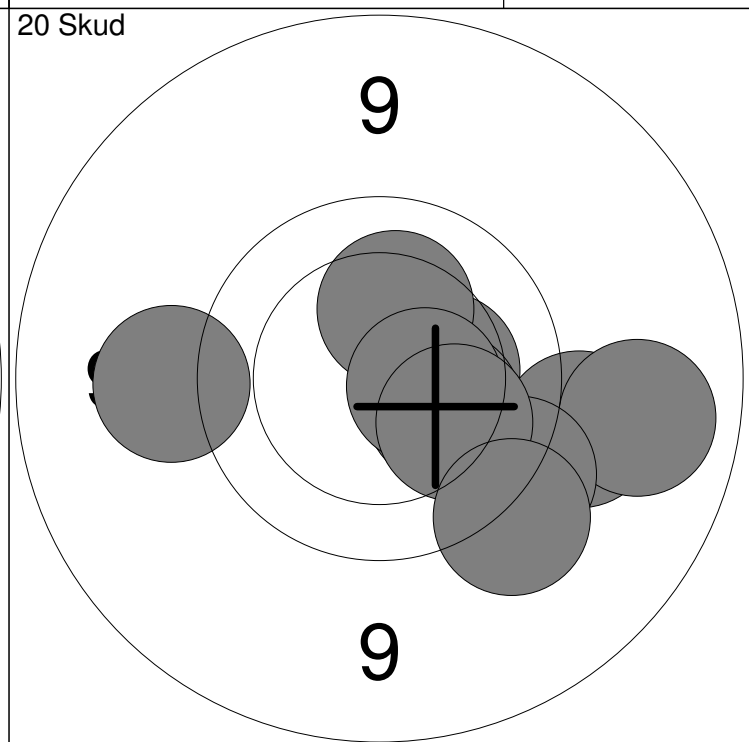
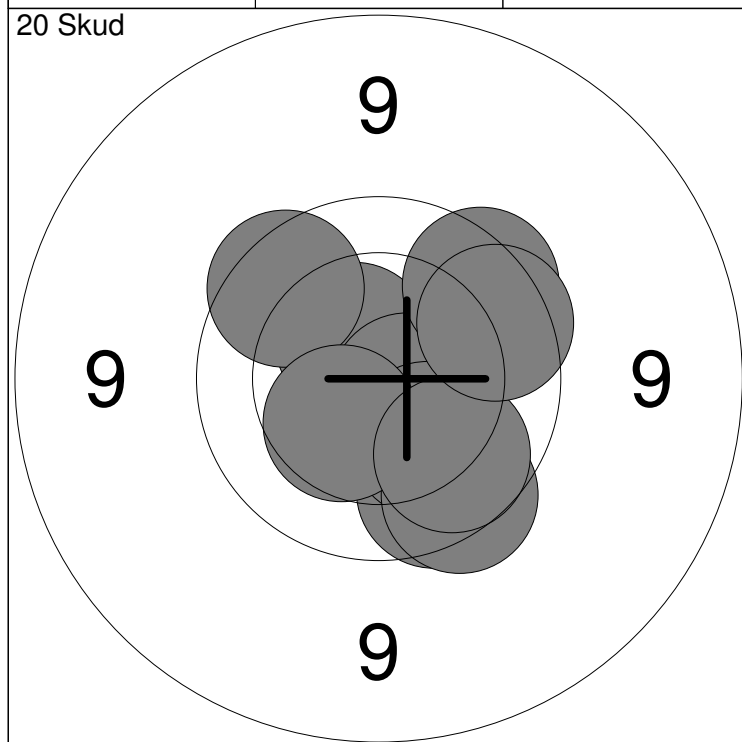

1: *10.5 ↗	6: 9.7 ↓	Serie	94.0
2: *10.6 ↘	7: 10.4 ↙		
3: 9.8 ↓	8: 9.9 ↓	Total	94.0
4: 10.2 ↓	9: 9.8 ↗		
5: 9.8 ↗	10: 9.8 ↗		

11: 10.3 →	16: 9.1 →	Serie	95.0
12: 10.3 →	17: 9.6 ↓		
13: 10.3 ↑	18: 10.1 ↓	Total	189.0
14: *10.5 →	19: 9.5 ↓		
15: 9.4 →	20: 9.4 ←		

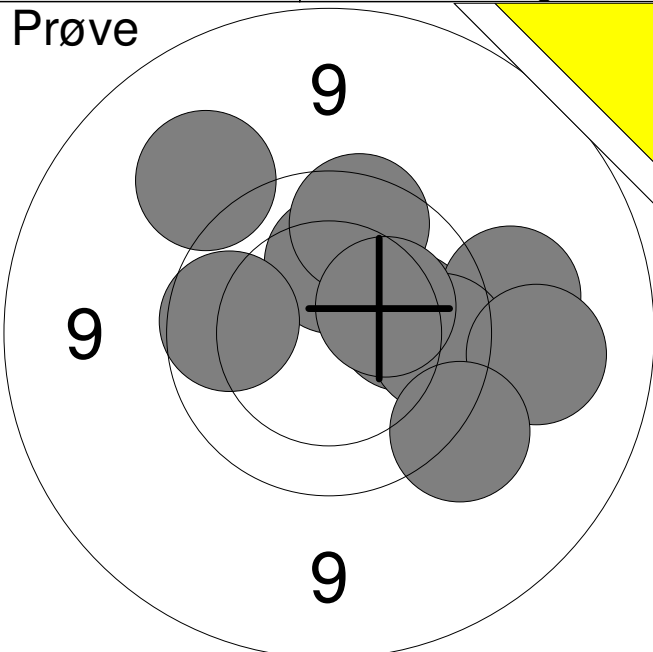
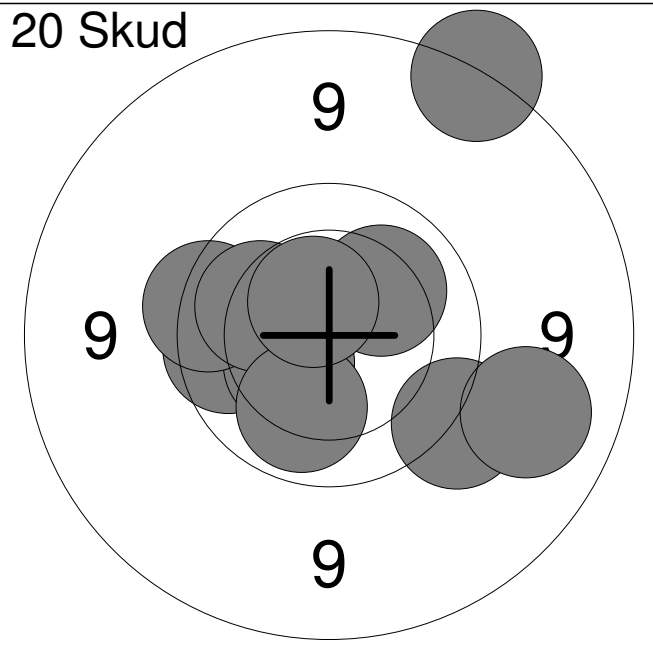
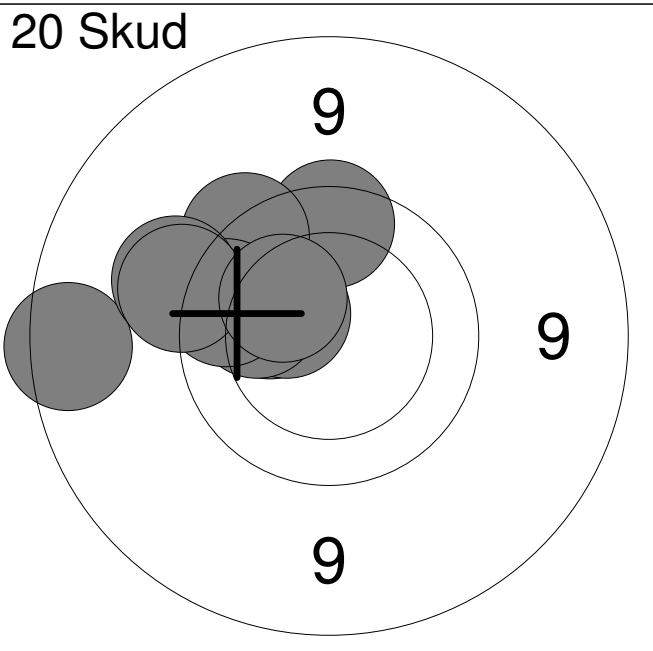
Hold	Skive	Lea Larsen		
6	8	Vester Han Herred Skytteforening MB3		MB3
15m		NM 15 meter Ungdom 2013		Aalborg Skyttekreds
1/3 - 3/3 2013				
Prøve 	1:	10.2	↑	
	2:	10.1	→	
	3:	9.9	←	
	4:	9.4	→	
	5:	9.8	→	
	6:	9.8	↑	
	7:	9.2	→	
	8:	9.5	↓	
	9:	10.3	→	
	10:	9.3	↗	
	Serie			93.0
Total			0.0	
20 Skud 	1:	9.9	←	
	2:	10.4	↙	
	3:	9.5	↘	
	4:	9.7	←	
	5:	10.1	↗	
	6:	10.2	↗	
	7:	10.1	↘	
	8:	9.1	→	
	9:	8.7	↗	
	10:	*10.5	↗	
	Serie			94.0
Total			94.0	
20 Skud 	11:	10.2	←	
	12:	9.8	↑	
	13:	9.7	↗	
	14:	8.8	←	
	15:	10.4	↗	
	16:	10.1	↗	
	17:	9.8	↗	
	18:	9.4	↗	
	19:	9.5	↗	
	20:	10.2	↗	
	Serie			93.0
Total			187.0	

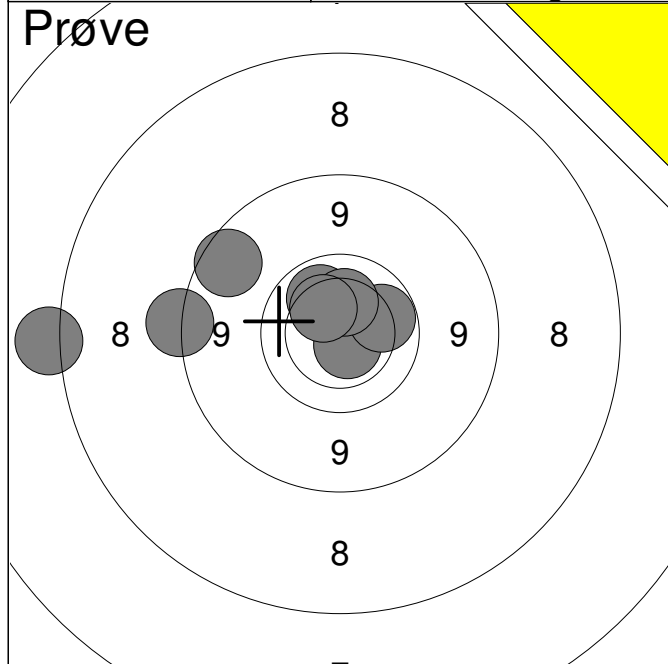

1:	8.7	←
2:	7.6	←
3:	*10.7	↙
4:	10.0	→
5:	8.9	↗
6:	10.1	↗
7:	10.3	↑
8:	10.3	↗
Serie		73.0
Total		0.0

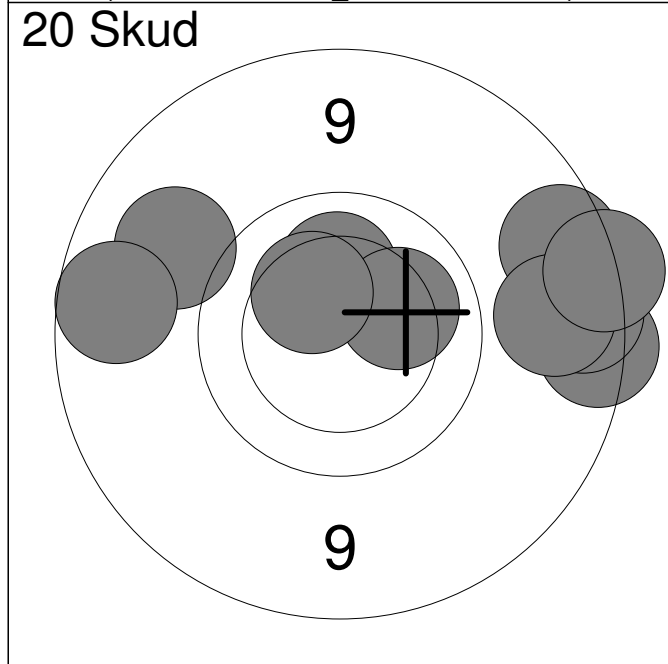

1:	8.8	→
2:	8.9	→
3:	10.2	↑
4:	9.2	↖
5:	8.9	→
6:	9.0	→
7:	8.7	→
8:	10.2	→
9:	8.9	←
10:	10.3	↗
Serie		88.0
Total		88.0

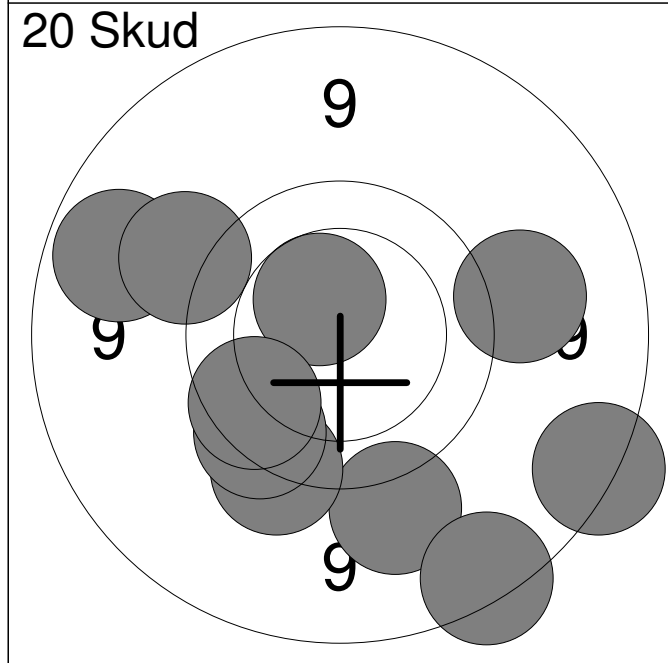

11:	9.3	↘
12:	9.6	↘
13:	9.3	→
14:	10.5	↗
15:	9.0	↖
16:	9.7	↙
17:	8.8	↘
18:	9.4	↗
19:	8.7	↘
20:	9.8	↙
Serie		89.0
Total		177.0

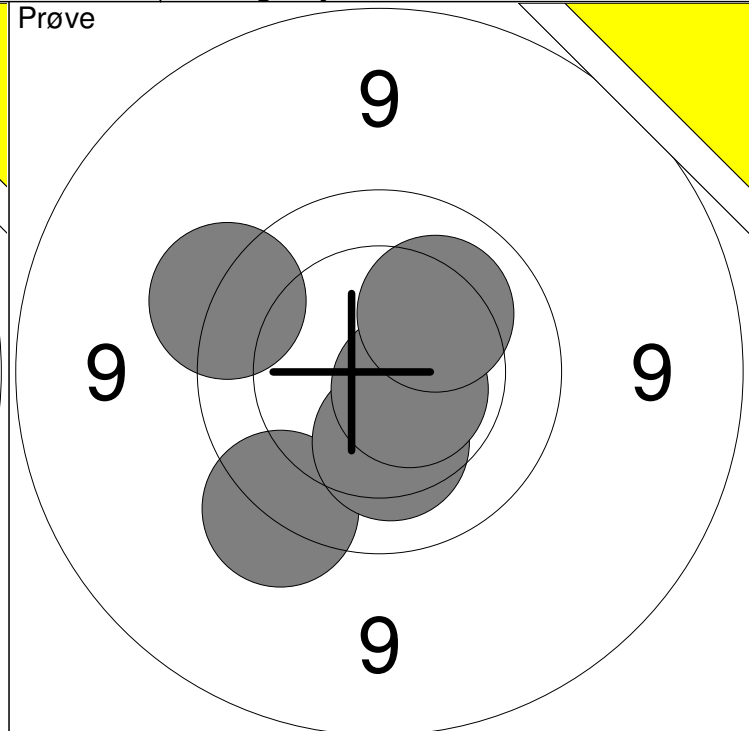
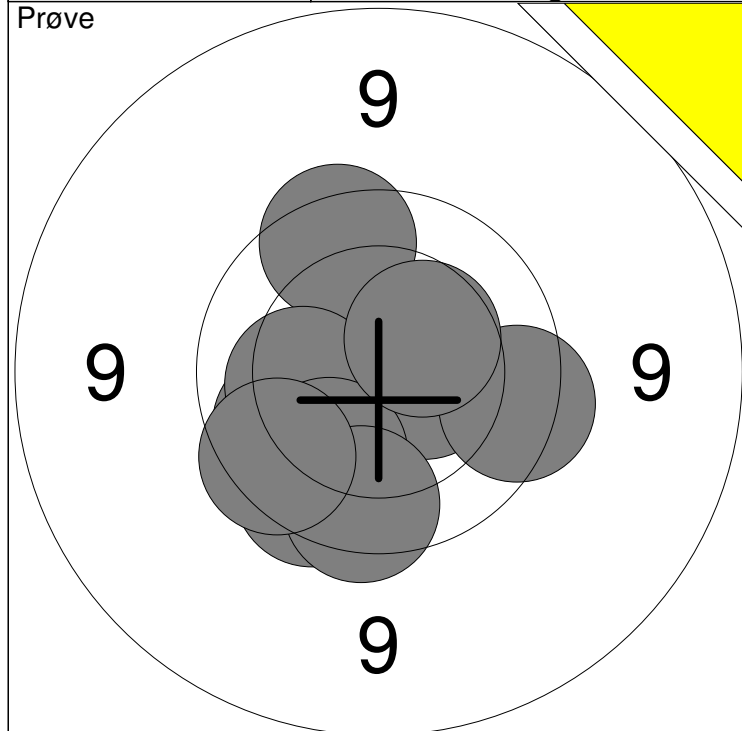

1: 9.8 ↗	6: 9.7 →	Serie	95.0
2: 10.0 ↙	7: 10.0 ↘		
3: *10.5 →	8: 9.8 ↓	Total	0.0
4: 10.2 ←	9: 9.8 ↙		
5: 9.8 ↘	10: 10.4 ↗		

11: 9.6 ↙	Serie	48.0
12: 10.3 ↓		
13: 9.6 ↖	Total	0.0
14: *10.6 →		
15: 10.2 ↗		

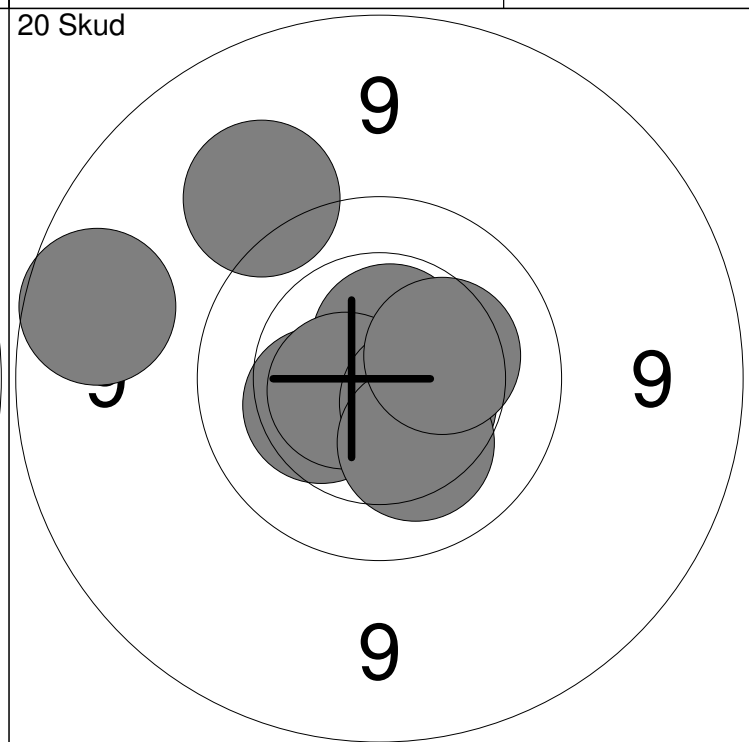
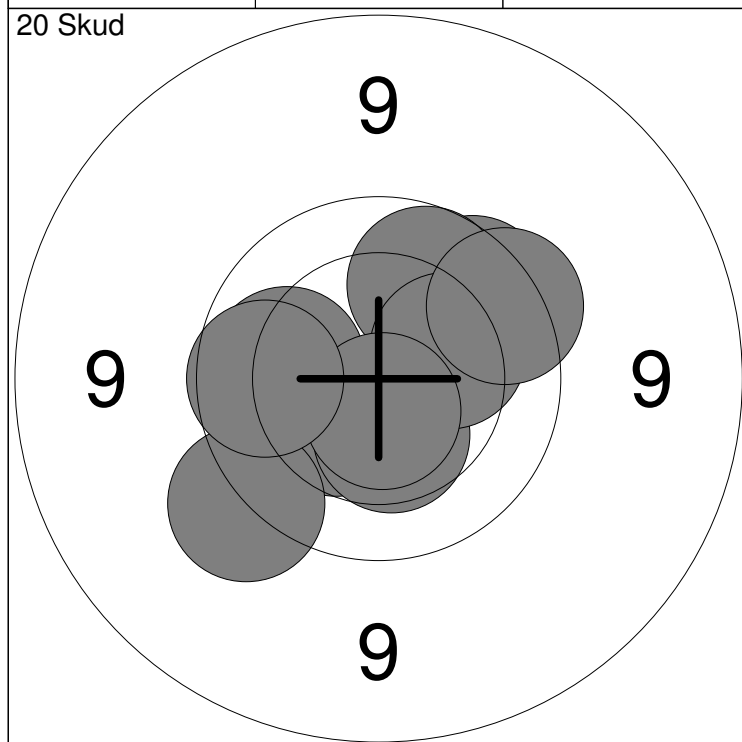

1: 10.4 ↙	6: 9.9 ↗	Serie	95.0
2: 10.1 ←	7: 10.2 →		
3: 9.8 ↗	8: 9.7 →	Total	95.0
4: 9.5 ↙	9: *10.6 ↓		
5: 10.4 ↘	10: 9.9 ←		

11: 9.3 ↖	16: 10.3 ←	Serie	97.0
12: 8.9 ←	17: *10.6 ↙		
13: *10.8 ←	18: *10.5 →	Total	192.0
14: *10.6 ↗	19: 10.2 ↓		
15: *10.6 ↗	20: 10.3 →		

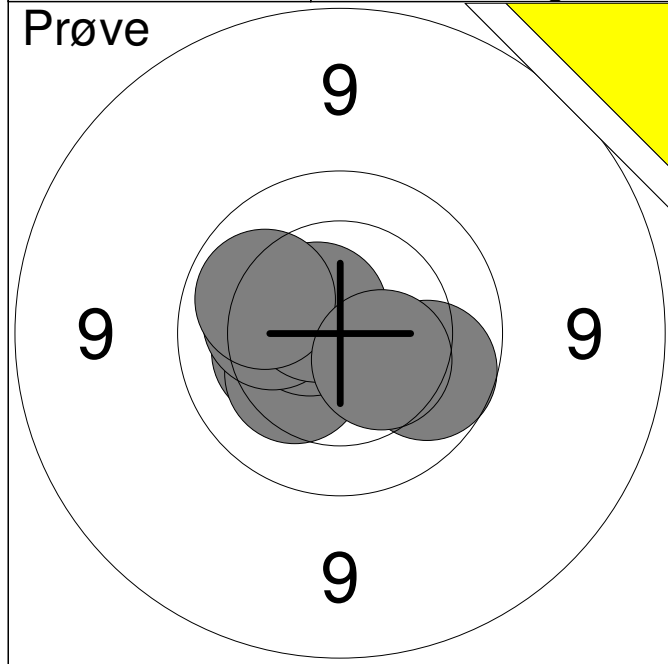

1:	9.9	➔
2:	10.3	➔
3:	10.3	➔
4:	*10.6	➔
5:	10.2	➔
6:	*10.6	➔
7:	10.1	➔
8:	10.4	➔
Serie		79.0
Total		0.0

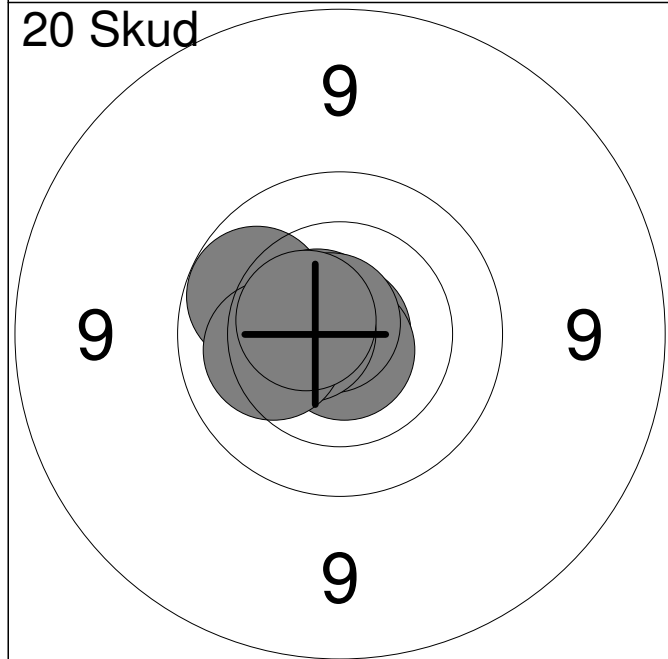

1:	*10.8	➔
2:	*10.7	➔
3:	10.0	➔
4:	*10.9	➔
5:	*10.7	➔
6:	*10.8	➔
7:	*10.8	➔
8:	*10.6	➔
9:	10.2	➔
10:	*10.6	➔
Serie		100.0
Total		100.0

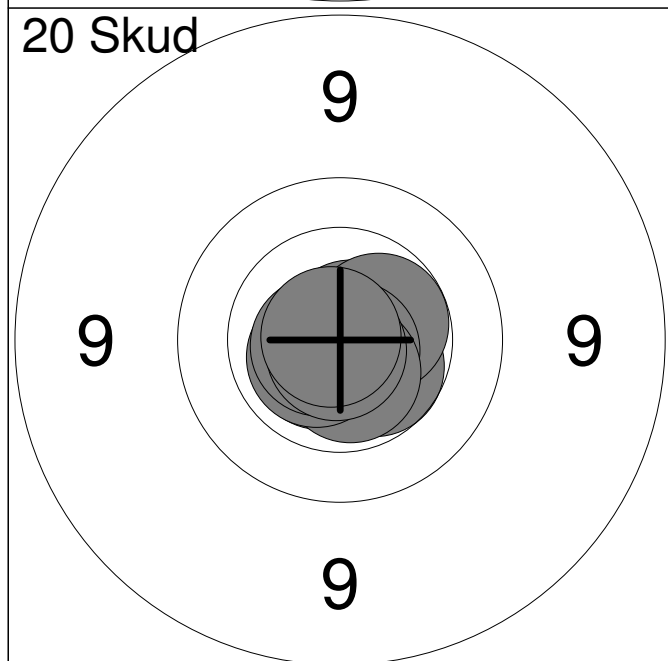

11:	*10.7	➔
12:	*10.8	➔
13:	10.5	➔
14:	*10.5	➔
15:	*10.8	➔
16:	*10.6	➔
17:	*10.6	➔
18:	*10.7	➔
19:	*10.8	➔
20:	*10.8	➔
Serie		100.0
Total		200.0

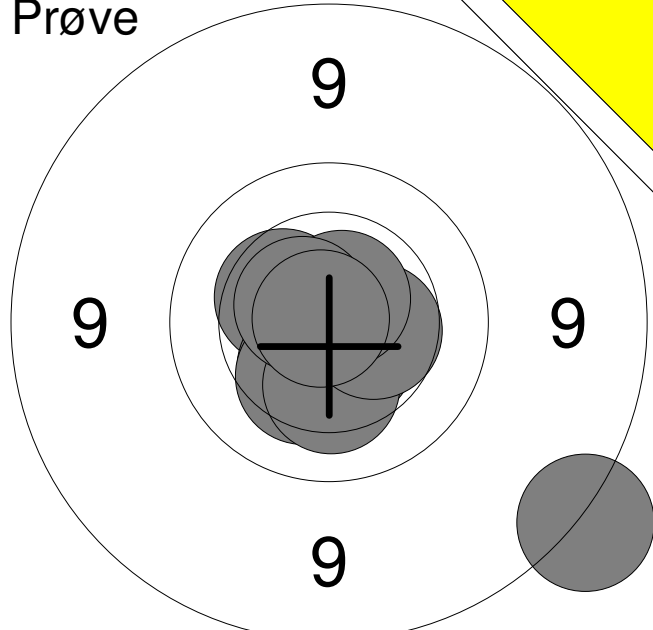
<p>Prøve</p> 	<table style="width:100%; border-collapse: collapse;"> <tr><td style="width:10%;">1:</td><td style="width:15%;">8.6</td><td style="width:10%; text-align: right;">↘</td></tr> <tr><td>2:</td><td>10.4</td><td style="text-align: right;">↗</td></tr> <tr><td>3:</td><td>10.4</td><td style="text-align: right;">↘</td></tr> <tr><td>4:</td><td>10.3</td><td style="text-align: right;">↘</td></tr> <tr><td>5:</td><td>*10.6</td><td style="text-align: right;">↘</td></tr> <tr><td>6:</td><td>10.3</td><td style="text-align: right;">↘</td></tr> <tr><td>7:</td><td>10.5</td><td style="text-align: right;">→</td></tr> <tr><td>8:</td><td>*10.7</td><td style="text-align: right;">↗</td></tr> <tr><td>9:</td><td>*10.6</td><td style="text-align: right;">↗</td></tr> <tr><td>10:</td><td>*10.8</td><td style="text-align: right;">↗</td></tr> <tr><td colspan="2">Serie</td><td style="text-align: right;">98.0</td></tr> <tr><td colspan="2">Total</td><td style="text-align: right;">0.0</td></tr> </table>	1:	8.6	↘	2:	10.4	↗	3:	10.4	↘	4:	10.3	↘	5:	*10.6	↘	6:	10.3	↘	7:	10.5	→	8:	*10.7	↗	9:	*10.6	↗	10:	*10.8	↗	Serie		98.0	Total		0.0
1:	8.6	↘																																			
2:	10.4	↗																																			
3:	10.4	↘																																			
4:	10.3	↘																																			
5:	*10.6	↘																																			
6:	10.3	↘																																			
7:	10.5	→																																			
8:	*10.7	↗																																			
9:	*10.6	↗																																			
10:	*10.8	↗																																			
Serie		98.0																																			
Total		0.0																																			

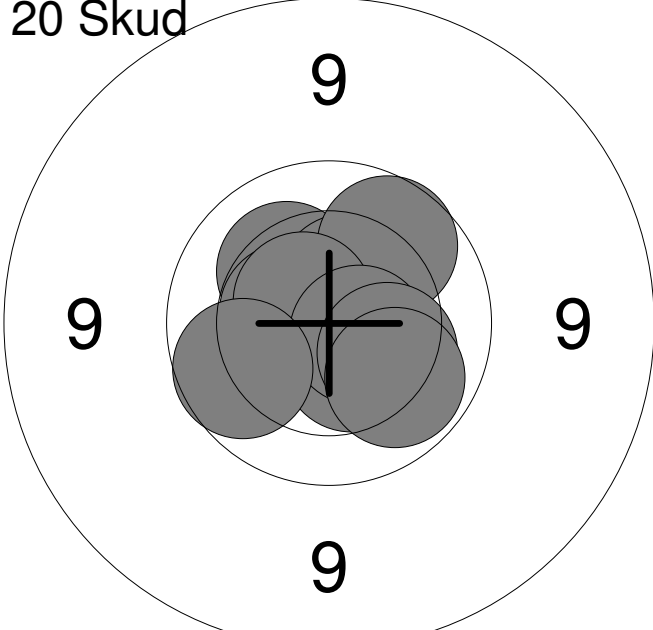
<p>20 Skud</p> 	<table style="width:100%; border-collapse: collapse;"> <tr><td style="width:10%;">1:</td><td style="width:15%;">10.5</td><td style="width:10%; text-align: right;">↘</td></tr> <tr><td>2:</td><td>10.2</td><td style="text-align: right;">↗</td></tr> <tr><td>3:</td><td>10.5</td><td style="text-align: right;">↗</td></tr> <tr><td>4:</td><td>*10.5</td><td style="text-align: right;">←</td></tr> <tr><td>5:</td><td>9.9</td><td style="text-align: right;">↗</td></tr> <tr><td>6:</td><td>*10.6</td><td style="text-align: right;">↗</td></tr> <tr><td>7:</td><td>*10.6</td><td style="text-align: right;">↘</td></tr> <tr><td>8:</td><td>10.2</td><td style="text-align: right;">↘</td></tr> <tr><td>9:</td><td>9.9</td><td style="text-align: right;">←</td></tr> <tr><td>10:</td><td>10.0</td><td style="text-align: right;">↘</td></tr> <tr><td colspan="2">Serie</td><td style="text-align: right;">98.0</td></tr> <tr><td colspan="2">Total</td><td style="text-align: right;">98.0</td></tr> </table>	1:	10.5	↘	2:	10.2	↗	3:	10.5	↗	4:	*10.5	←	5:	9.9	↗	6:	*10.6	↗	7:	*10.6	↘	8:	10.2	↘	9:	9.9	←	10:	10.0	↘	Serie		98.0	Total		98.0
1:	10.5	↘																																			
2:	10.2	↗																																			
3:	10.5	↗																																			
4:	*10.5	←																																			
5:	9.9	↗																																			
6:	*10.6	↗																																			
7:	*10.6	↘																																			
8:	10.2	↘																																			
9:	9.9	←																																			
10:	10.0	↘																																			
Serie		98.0																																			
Total		98.0																																			

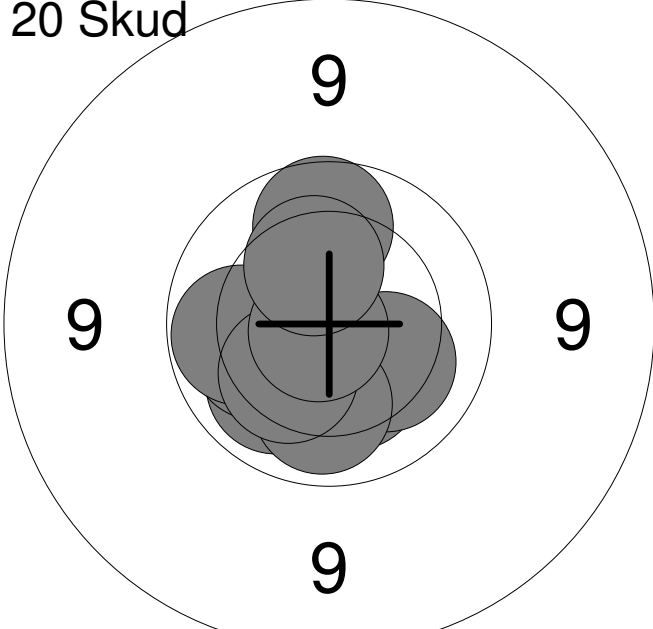
<p>20 Skud</p> 	<table style="width:100%; border-collapse: collapse;"> <tr><td style="width:10%;">11:</td><td style="width:15%;">10.3</td><td style="width:10%; text-align: right;">↘</td></tr> <tr><td>12:</td><td>10.1</td><td style="text-align: right;">↘</td></tr> <tr><td>13:</td><td>10.1</td><td style="text-align: right;">←</td></tr> <tr><td>14:</td><td>10.0</td><td style="text-align: right;">←</td></tr> <tr><td>15:</td><td>10.2</td><td style="text-align: right;">↘</td></tr> <tr><td>16:</td><td>10.1</td><td style="text-align: right;">↘</td></tr> <tr><td>17:</td><td>10.3</td><td style="text-align: right;">↘</td></tr> <tr><td>18:</td><td>9.9</td><td style="text-align: right;">↑</td></tr> <tr><td>19:</td><td>*10.8</td><td style="text-align: right;">←</td></tr> <tr><td>20:</td><td>10.3</td><td style="text-align: right;">↗</td></tr> <tr><td colspan="2">Serie</td><td style="text-align: right;">99.0</td></tr> <tr><td colspan="2">Total</td><td style="text-align: right;">197.0</td></tr> </table>	11:	10.3	↘	12:	10.1	↘	13:	10.1	←	14:	10.0	←	15:	10.2	↘	16:	10.1	↘	17:	10.3	↘	18:	9.9	↑	19:	*10.8	←	20:	10.3	↗	Serie		99.0	Total		197.0
11:	10.3	↘																																			
12:	10.1	↘																																			
13:	10.1	←																																			
14:	10.0	←																																			
15:	10.2	↘																																			
16:	10.1	↘																																			
17:	10.3	↘																																			
18:	9.9	↑																																			
19:	*10.8	←																																			
20:	10.3	↗																																			
Serie		99.0																																			
Total		197.0																																			

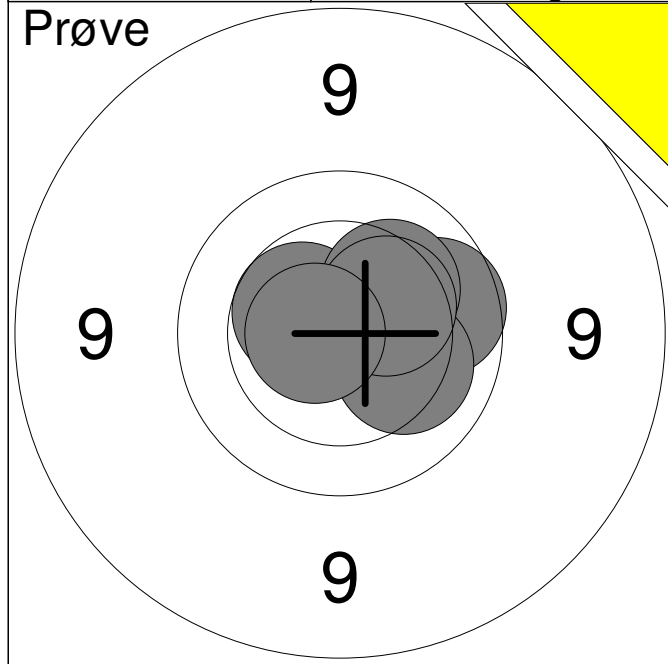

1:	10.5	↖
2:	9.9	→
3:	10.2	↘
4:	10.2	↗
5:	10.4	↗
6:	*10.7	←
Serie		59.0
Total		0.0

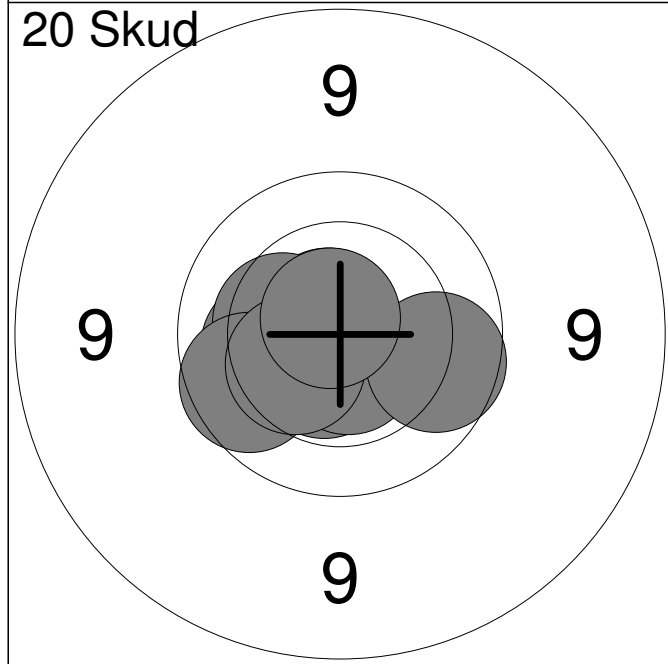

1:	*10.5	↓
2:	*10.7	↗
3:	10.2	←
4:	*10.6	←
5:	10.3	←
6:	*10.6	↓
7:	9.9	→
8:	9.9	←
9:	10.4	↙
10:	*10.7	↗
Serie		98.0
Total		98.0

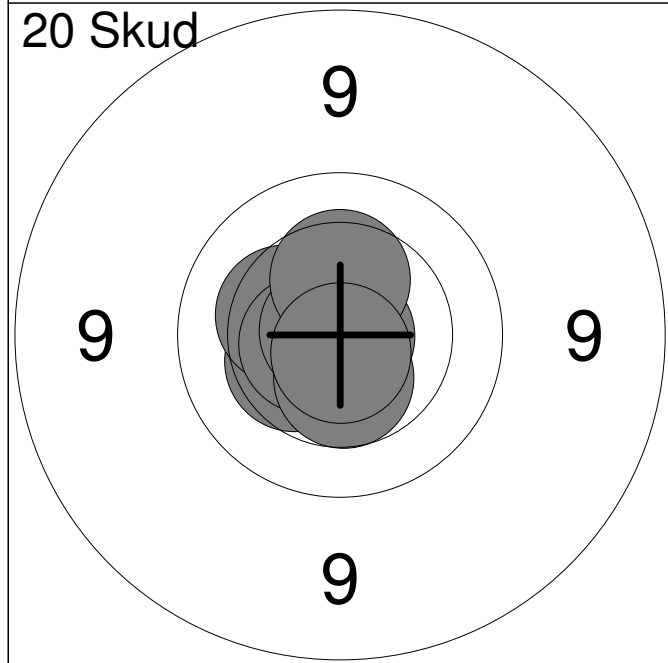

11:	10.4	←
12:	*10.6	↗
13:	10.3	↖
14:	*10.7	↙
15:	*10.9	→
16:	*10.6	←
17:	10.5	↓
18:	*10.8	↗
19:	10.4	↑
20:	*10.8	↓
Serie		100.0
Total		198.0

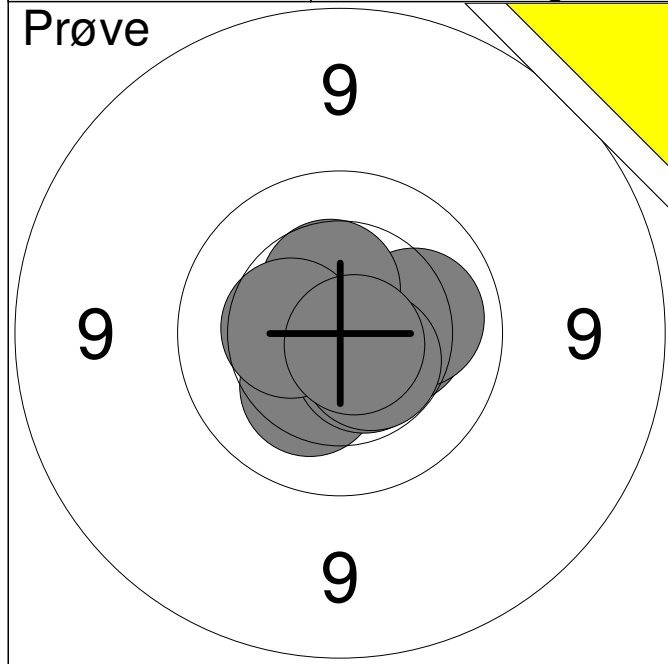

1:	10.3	↙
2:	*10.5	↘
3:	10.3	→
4:	10.1	→
5:	*10.5	↘
6:	10.5	↑
7:	10.4	←
8:	*10.8	↘
Serie		80.0
Total		0.0

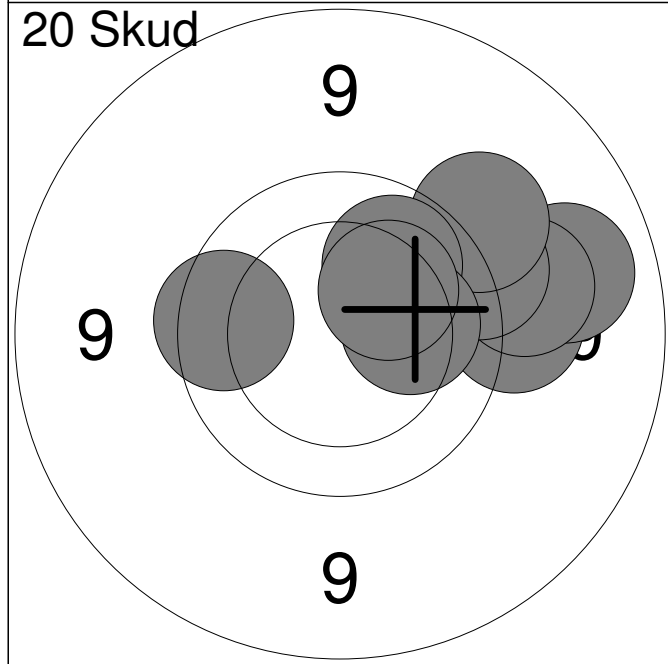

1:	9.4	→
2:	9.1	→
3:	9.3	→
4:	10.0	↗
5:	9.6	↗
6:	9.8	←
7:	9.4	↗
8:	10.0	↗
9:	10.2	→
10:	10.2	↗
Serie		94.0
Total		94.0

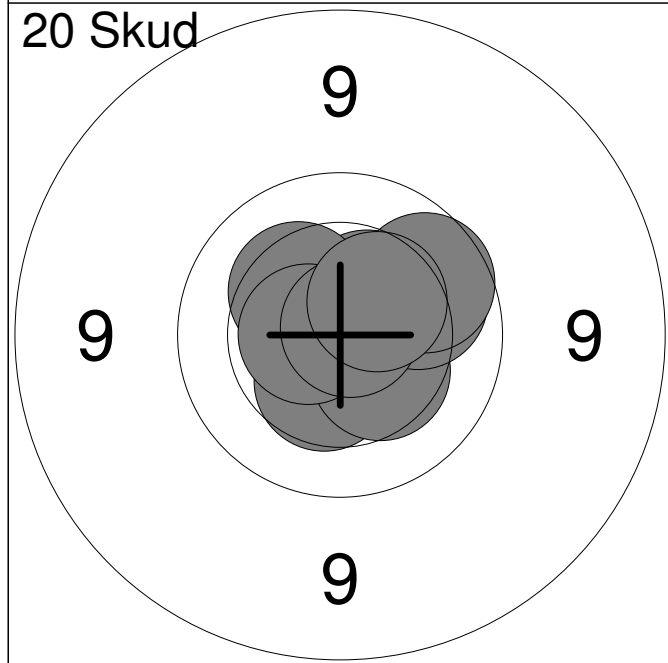

11:	10.4	↘
12:	10.4	↘
13:	10.5	↗
14:	10.0	→
15:	9.9	↗
16:	*10.6	←
17:	10.3	↗
18:	*10.6	←
19:	*10.8	↗
20:	10.4	↗
Serie		99.0
Total		193.0

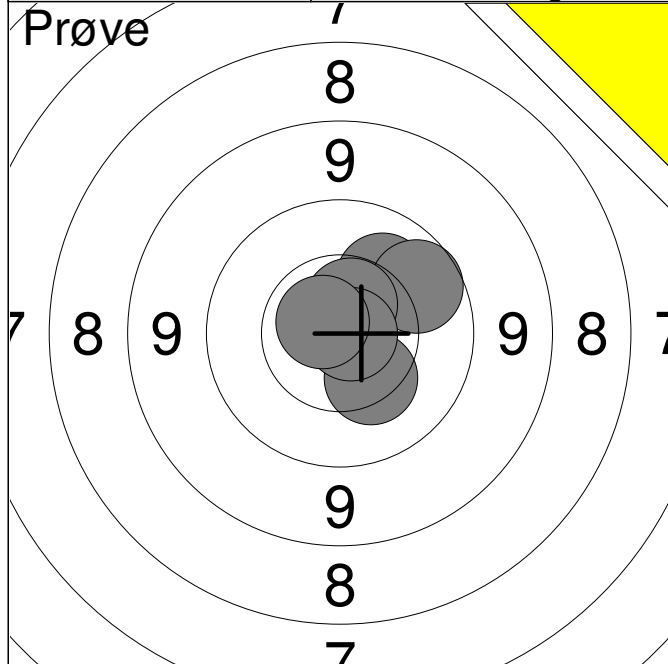

1:	10.2	↗
2:	9.9	↗
3:	*10.6	↗
4:	10.3	↘
5:	*10.8	→
6:	*10.7	↗
Serie		59.0
Total		0.0

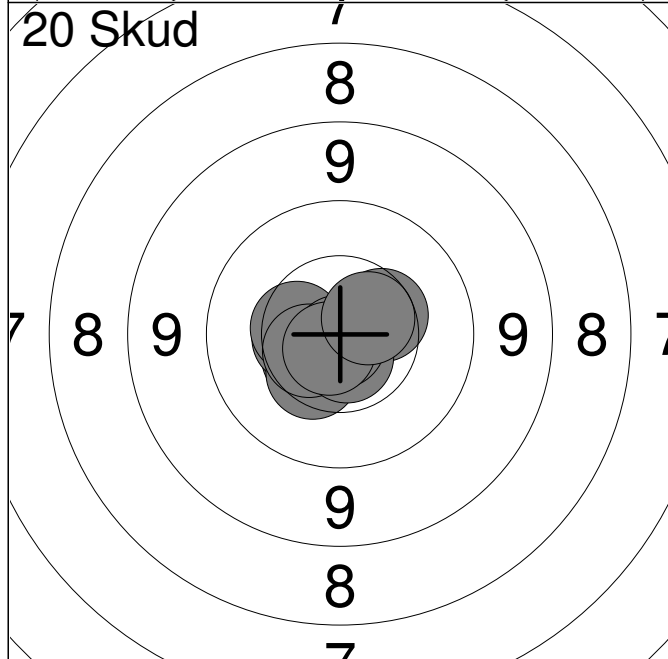

1:	10.5	↙
2:	10.5	←
3:	10.4	→
4:	10.4	←
5:	10.4	↙
6:	10.5	↙
7:	*10.7	↘
8:	*10.9	↘
9:	*10.7	↙
10:	10.6	↗
Serie		100.0
Total		100.0

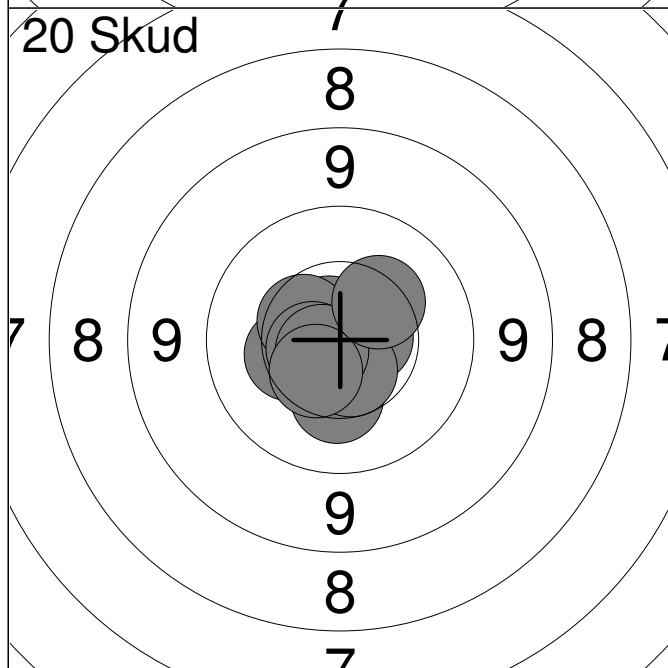

11:	10.4	←
12:	10.3	↘
13:	*10.6	→
14:	*10.7	↗
15:	10.6	↘
16:	10.5	↗
17:	*10.6	←
18:	*10.7	↙
19:	10.5	↙
20:	10.3	↗
Serie		100.0
Total		200.0

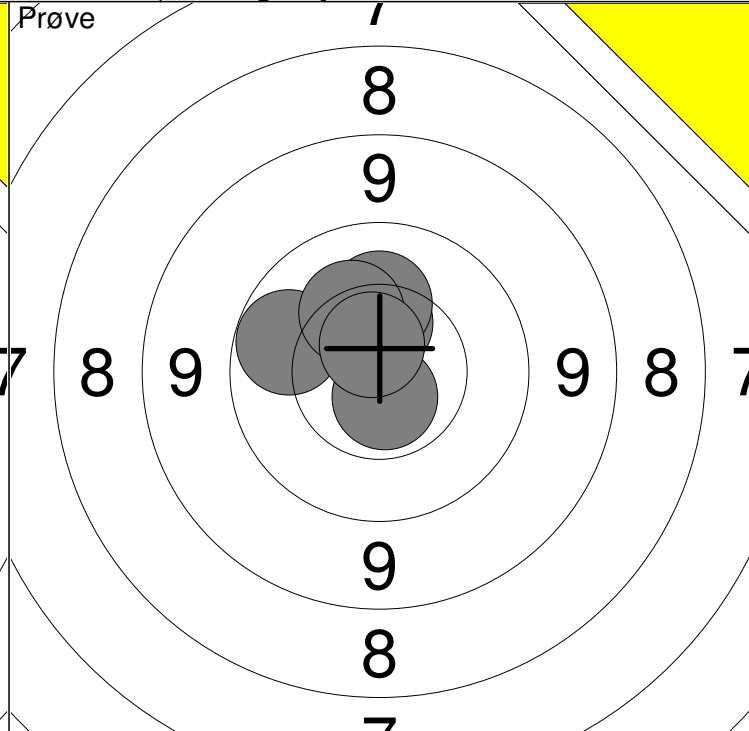
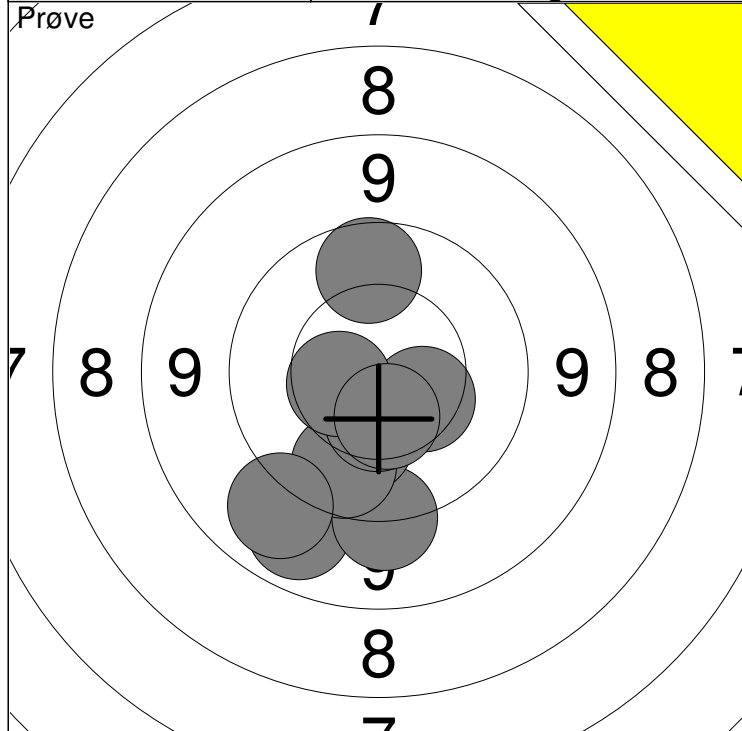

1: 9.1 ↓	6: 10.4 ↘	Serie 95.0
2: 9.4 ↓	7: 10.5 ←	
3: 10.2 ↓	8: 9.2 ↓	Total 0.0
4: 9.9 ↓	9: 10.5 ↓	
5: 10.5 ↓	10: 9.9 ↑	

11: 10.4 ↗	16: 10.3 ↗	Serie 70.0
12: 10.0 ←	17: *10.7 ↗	
13: *10.7 ↓	14: 10.4 ↑	Total 0.0
15: 10.2 ↑		

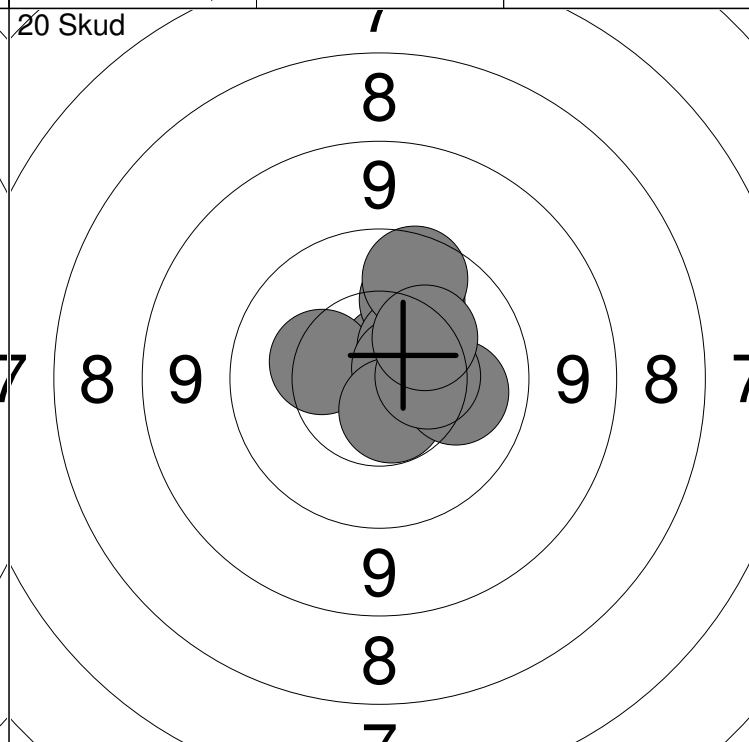
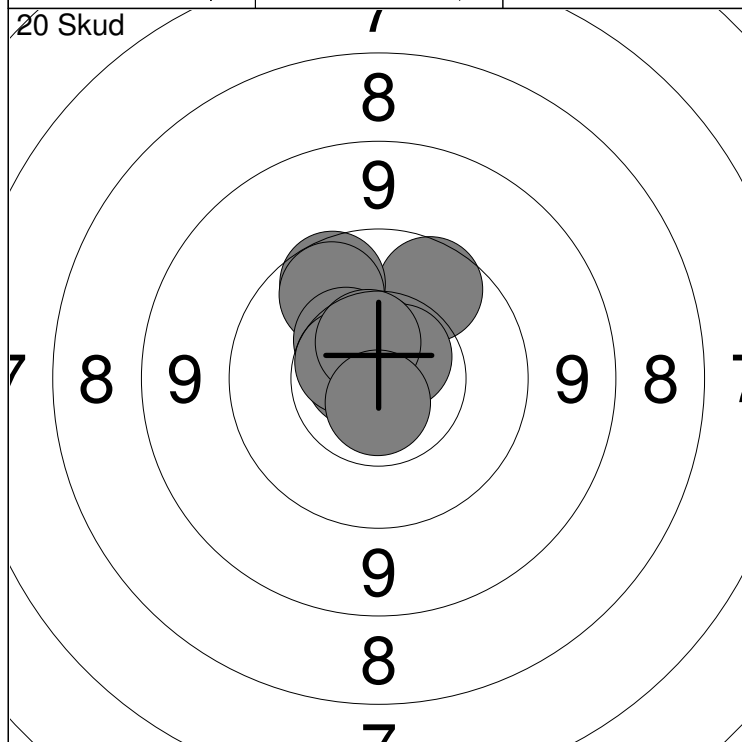

1: *10.7 ←	6: *10.6 ↗	Serie 98.0
2: 9.9 ↗	7: 10.4 ↗	
3: *10.6 ↑	8: *10.6 ↗	Total 98.0
4: 9.9 ↗	9: 10.6 ↑	
5: 10.0 ↗	10: *10.7 ↓	

11: *10.7 ↗	16: *10.7 ↗	Serie 99.0
12: 10.3 ←	17: *10.6 ↓	
13: 10.1 ↑	18: 10.1 →	Total 197.0
14: 10.5 ↗	19: 10.4 →	
15: 9.8 ↑	20: 10.3 ↗	

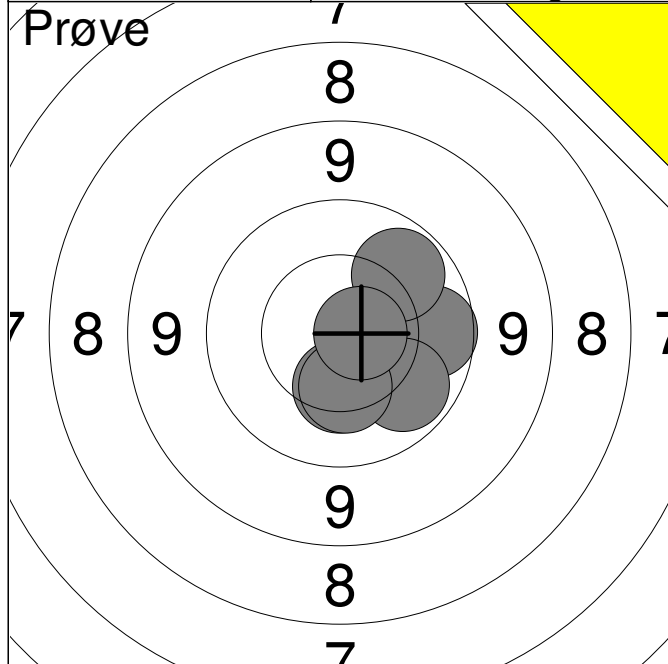

1:	9.9	→
2:	10.0	↘
3:	10.3	↓
4:	10.0	↗
5:	10.3	↓
6:	*10.7	→
Serie		59.0
Total		0.0

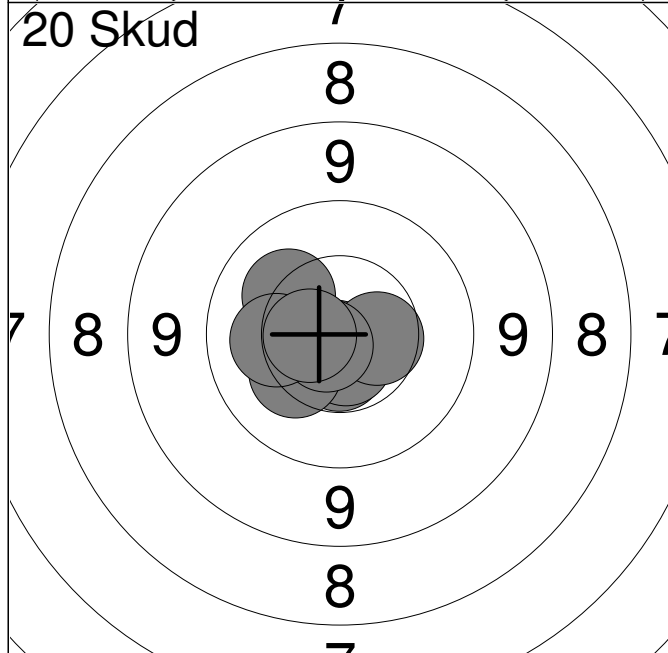

1:	*10.8	↘
2:	10.2	↗
3:	*10.6	↓
4:	*10.7	↓
5:	10.3	←
6:	10.5	→
7:	10.3	↙
8:	*10.7	↙
9:	10.2	←
10:	*10.6	←
Serie		100.0
Total		100.0

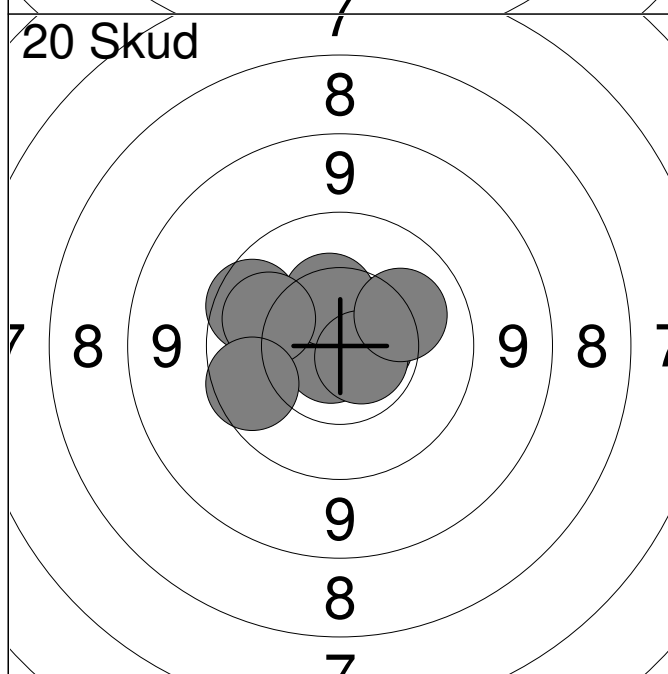

11:	*10.8	↙
12:	*10.6	↗
13:	*10.6	↗
14:	*10.6	→
15:	10.4	↑
16:	9.8	↗
17:	10.1	↙
18:	9.8	←
19:	*10.7	↘
20:	10.2	↗
Serie		98.0
Total		198.0

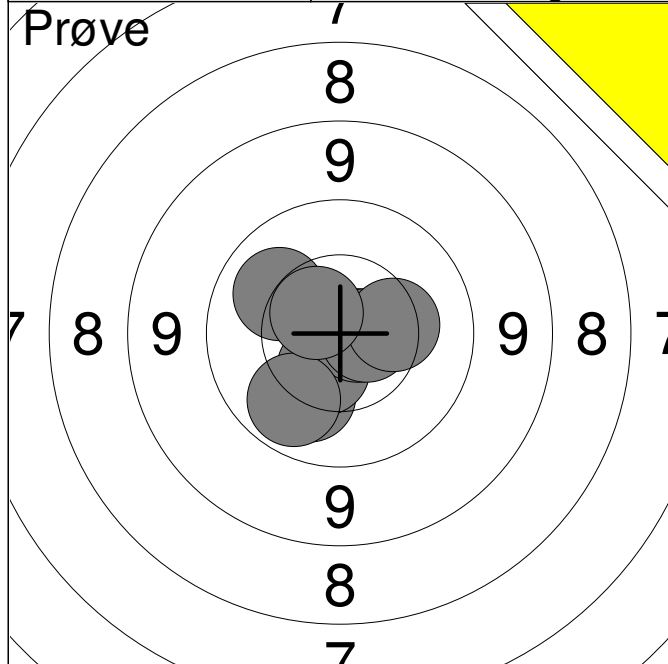

1:	10.1	↙
2:	10.5	↙
3:	*10.8	→
4:	*10.6	→
5:	10.3	→
6:	10.0	↙
7:	10.1	↗
8:	*10.6	↗
Serie		80.0
Total		0.0

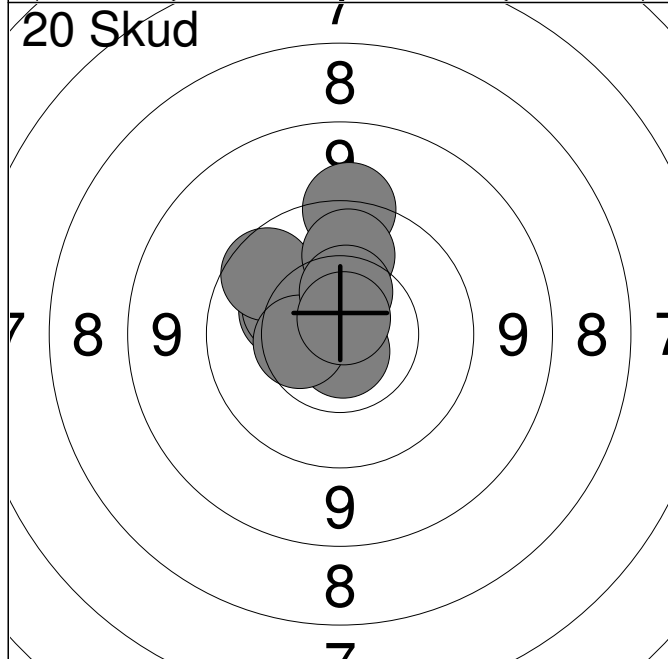

1:	9.5	↑
2:	*10.8	↓
3:	10.3	↖
4:	10.3	↖
5:	10.4	↗
6:	9.9	↗
7:	10.0	↑
8:	10.5	←
9:	10.5	↑
10:	*10.8	↑
Serie		98.0
Total		98.0

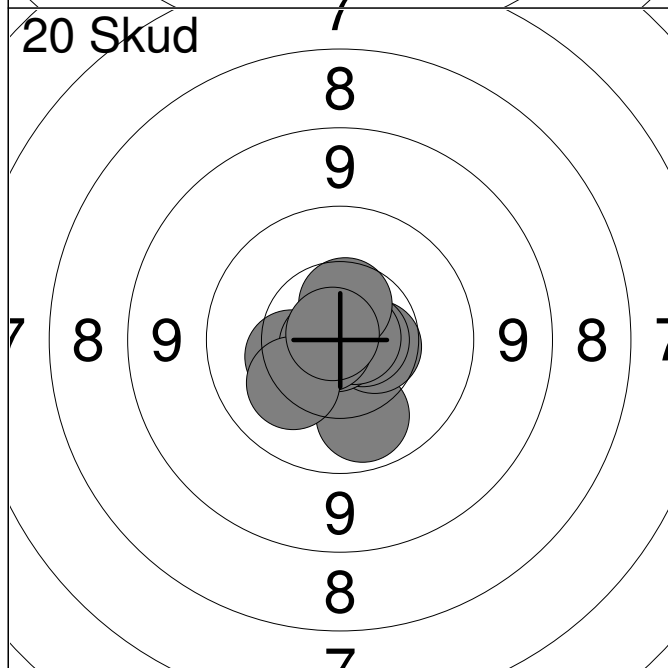

11:	10.0	↓
12:	10.4	←
13:	10.5	→
14:	*10.7	→
15:	*10.9	↙
16:	*10.8	→
17:	*10.8	←
18:	10.2	↙
19:	10.5	↑
20:	*10.8	↖
Serie		100.0
Total		198.0